

**BONENG**



## C Helical Gearmotor

Modified date 04/2020  
Selection Sample C05.0009-EN

**Boneng Transmission**

**Boneng Transmission enhances reliable, accurate, efficient and intelligent operation in the industry**

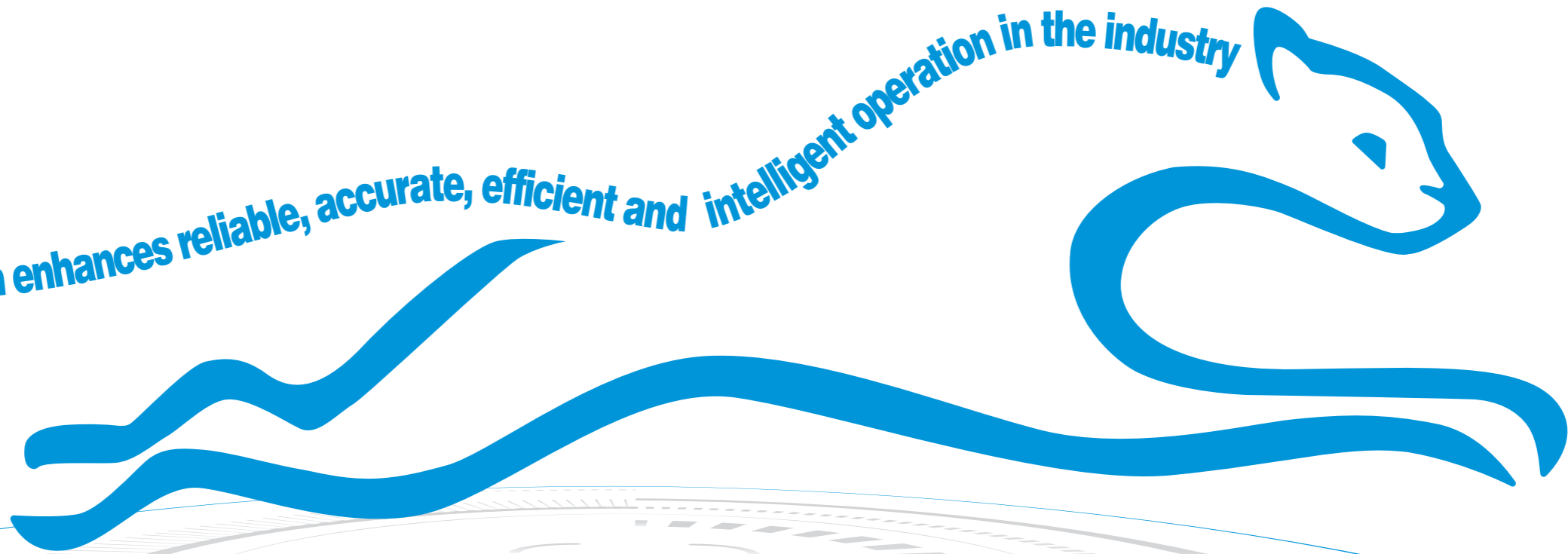

Boneng Transmission More products: drive / motor / gear motor / gear box  
Please browse: [www.boneng.com](http://www.boneng.com)

## Note:

- ◆ The structure scheme, appearance diagram and other attached diagrams in sample are examples, there is no strict proportion requirement. (The unmarked dimension units are mm).
- ◆ The marked weight is average value, it has no constraint force.

## You must conform to the following instructions:

- ◆ To prevent accidents, all the rotation parts are added with protective covers according to the safety regulations of the nation and region.
- ◆ Before debugging, you should carefully read instruction book.
- ◆ Gearbox is on running—permission status when delivered, you should add lubrication oil before putting it into running.
- ◆ The marked oil quantity in sample is only reference value, actual oil filling quantity should be the same with the mark on oil immersion lens.
- ◆ Lubrication oil viscosity should be selected according to working situation and application environment temperature of gearmotor.
- ◆ You can only apply lubrication oil of internationally famous brand.

## Product Function Mark



Oil glass



Breather



Oil filler

# Contents

▲.....	Type Designation	01
▲.....	Sectional Drawings	03
▲.....	Mounting Positions	04
▲.....	Type Selection and Example	05
▲.....	Transmission Capacity	07
▲.....	Dimensions	15
▲.....	Input Flange and Input shaft	41
▲.....	Combi-type Dimensions	46
▲.....	Oil Compensating Tank	47
▲.....	Oil	48
▲.....	Motor Rainproof Cover Dimensions	49
▲.....	Permissible Radial Force	49
▲.....	Shaft End Centre Hole	51
▲.....	Dimension of Parallel Key and Keyway	52

# 1 Type Designation

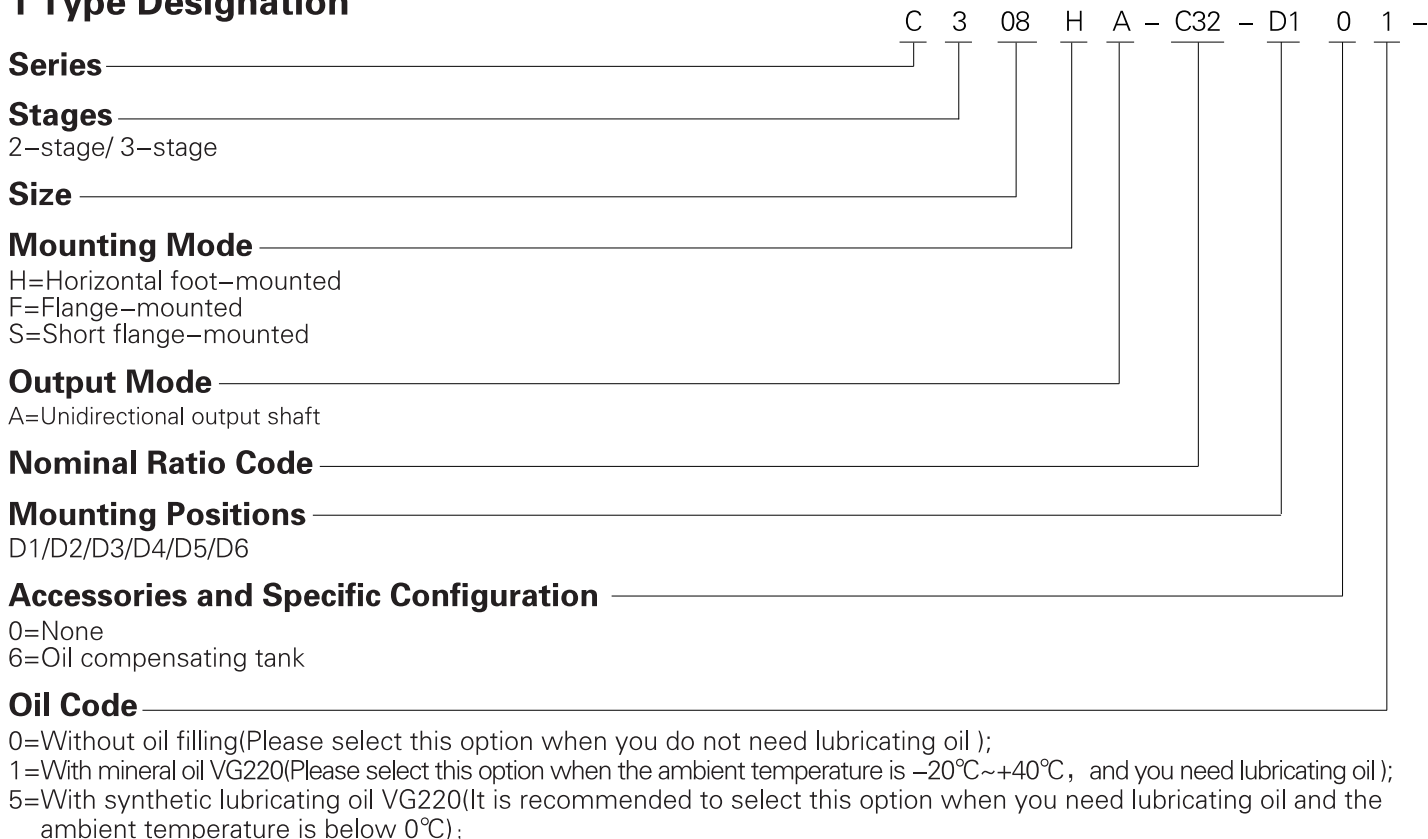

## Note<sup>1)</sup> Motor Type/Frame Size/Poles/Power Code

Power kW	4-pole type	6-pole type	Power kW	4-pole type	6-pole type	Power kW	4-pole type	6-pole type	Power kW	4-pole type	6-pole type
0.09	MS056M4A09 <sup>2)</sup>		1.1	MS090S4B11 MH090S4B11 MP090S4B11 MA090S4B11	MH090S6B11 MP090M6B11	11	MH160S4C11 MP160M4C11 MA160M4C11	MH160M6C11 MP160M6C11	55	MH250M4C55 MP250M4C55 MA250M4C55	MH280M6C55 MP280M6C55
0.12	MS056M4A12 <sup>2)</sup> MH063M4A12 MP063M4A12 MA063M4A12		1.5	MS090S4B15 MH090S4B15 MP090M4B15 MA090M4B15	MH100M6B15 MP100M6B15	15	MH160M4C15 MP160L4C15 MA160L4C15	MH180M6C15 MP180M6C15	75	MH280S4C75 MP280S4C75 MA280S4C75	MH315S6C75 MP315S6C75
0.18	MH063M4A18 MP063M4A18 MA063M4A18	MH071M6A18 MP071M6A18	2.2	MS100M4B22 MH100M4B22 MP100M4B22 MA100M4B22	MH112M6B22 MP112M6B22	18.5	MH180M4C18 MP180M4C18 MA180M4C18	MH200M6C18 MP200M6C18	90	MH280M4C90 MP280M4C90 MA280M4C90	MH315M6C90 MP315M6C90
0.25	MS063M4A25 <sup>2)</sup> MH071M4A25 MP071M4A25 MA071M4A25	MH071M6A25 MP071M6A25	3	MS100M4B30 MH100M4B30 MP100M4B30 MA100M4B30	MH132S6B30 MP132S6B30	22	MH180L4C22 MP180L4C22 MA180L4C22	MH200M6C22 MP200M6C22	110	MH315S4D11 MP315S4D11	MH315L6D11
0.37	MH071M4A37 MP071M4A37 MA071M4A37	MH080M6A37 MP080M6A37	4	MS112M4B40 MH112L4B40 MP112L4B40 MA112L4B40	MH132M6B40 MP132S6B40	30	MH200M4C30 MP200M4C30 MA200M4C30	MH225M6C30 MP225M6C30	132	MH315M4D13 MP315M4D13	MH315L6D13
0.55	MS071M4A55 <sup>2)</sup> MS080M4A55 MH080M4A55 MP080M4A55 MA080M4A55	MH080M6A55 MP080M6A55	5.5	MS132S4B55 MH132S4B55 MP132M4B55 MA132M4B55	MH132M6B55 MP132M6B55	37	MH225M4C37 MP225M4C37 MA225M4C37	MH250M6C37 MP250M6C37	160	MH315L4D16 MP315L4D16	
0.75	MS080M4A75 MH080M4A75 MP080M4A75 MA080M4A75	MH090S6A75 MP090S6A75	7.5	MS132M4B75 MH132M4B75 MP132L4B75 MA132L4B75	MH160S6B75 MP160S6B75	45	MH225M4C45 MP225M4C45 MA225M4C45	MH280S6C45 MP280S6C45	200	MH315L4D20 MP315L4D20	

Note<sup>2)</sup> Be applied to C200/C300/C201/C301

MH 132S 4 B55 A C 3 - A 0 B 1 0 - 0 1 1

### Cable Entry Position

1 / 2 / 3 / 4

### Terminal Box Position

1 / 2 / 3 / 4

### Motor mounting Position 0

### Motor protection

0=IP55 and Without rainproof cover    2=IP56 and Without rainproof cover    4=IP65 and Without rainproof cover  
1=IP55 and With rainproof cover    3=IP56 and With rainproof cover    5=IP65 and With rainproof cover

### Thermal Protection and Heating Protection

0=Without thermal protection and heating Protection    2=Thermal switch    5=Thermistor and heating belt  
1=Thermistor    3= PT100 temperature sensor    6=Thermal switch and heating belt  
4=Heating belt    7= PT100 temperature sensor and heating belt

### Brake

N=Without brake

A=Brake 220-240VAC

B=Brake 380-415VAC

C=Brake 440-480VAC

D=Brake with release handle 220-240VAC

E=Brake with release handle 380-415VAC

F=Brake with release handle 440-480VAC

G=Brake with self-lock device 220-240VAC

H=Brake with self-lock device 380-415VAC

J=Brake with self-lock device 440-480VAC

K=Brake with micro switch 220-240VAC

L=Brake with micro switch 380-415VAC

M=Brake with micro switch 440-480VAC

P=Double-brakes 220-240VAC

Q=Double-brakes 380-415VAC

X=Double-brakes 440-480VAC

R=Double-brakes with release handle 220-240VAC

S=Double-brakes with release handle 380-415VAC

T=Double-brakes with release handle 440-480VAC

### Encoder

0=Without encoder

1=With encoder

### Cooling

A=Self-fan cooling

F=Driven fan

### Frequency/Voltage Code

1=50Hz 220V Δ/380VY

2=50Hz 230V Δ/400VY

3=50Hz 380V Δ/660VY

4=50Hz 400V Δ/690VY

A=50Hz 240V Δ/415VY

B=50Hz 415V Δ

5=60Hz 440V Δ

6=60Hz 460V Δ

7=60Hz 440V Y

8=60Hz 460VY

C=60Hz 480VY

D=60Hz 480V Δ

E=60Hz 220V Δ/380VY

F=60Hz 380V Δ

G=60Hz 230VY

H=60Hz 230V Δ

J=60Hz 575VY

K=60Hz 575V Δ

Note: 3kW and below "Y", alternative code: 1,2,7,8,A,C,E;

4kW and above "Δ", alternative code: 3,4,5,6,B,D,F.

MA motor exclusive code: 6,8,G,H,J,K.

### Frame Material

L=Die-casting aluminum frame(standard configuration of 100 and below)

C=Grey cast iron frame(standard configuration of 112 and above)

### Mounting Mode A

### Power Code<sup>1)</sup>

### Motor Poles<sup>1)</sup>

4=4-pole; 6=6-pole

### Frame Size<sup>1)</sup>

### Motor Type<sup>1)</sup>

MS=Three-phase asynchronous motor (IE1)

MH=High efficiency three-phase asynchronous motor (IE2)

MP=Premium Efficiency three-phase asynchronous motor (IE3)

MA=NEMA efficiency three-phase asynchronous motor

YZ=Crane and metallurgical applications three-phase asynchronous motor

YG=Variable-frequency three-phase induction motor for roll table application

◆ **Example of product type with input flange or input shaft:** C308HA-C32-D101-AE3

◆ **Example of product type with input flange and motor type:** C308HA-C32-D101-AP132-MH132S4B55FC3-A0N10-011

◆ **Combi-type Designation:** C308HA/C205-D28-D100-MH080M4A75AL1-A0N00-011

## 2 Sectional Drawings

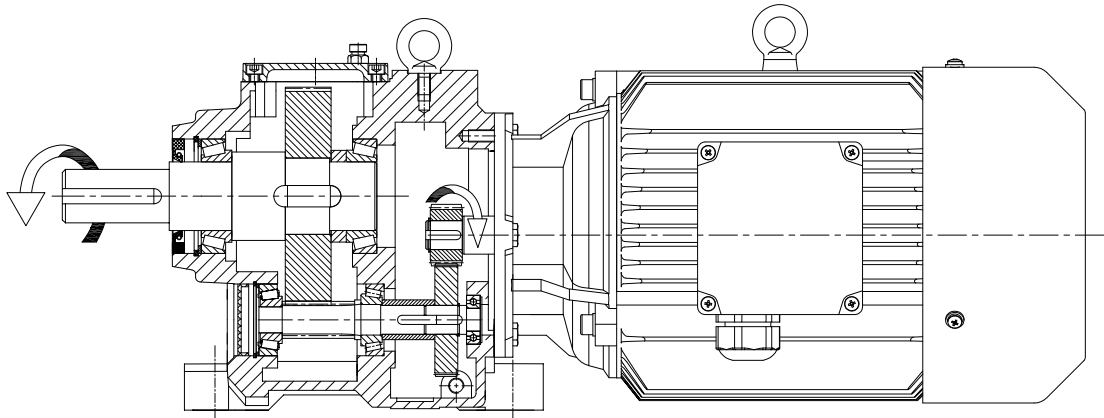

2-stage

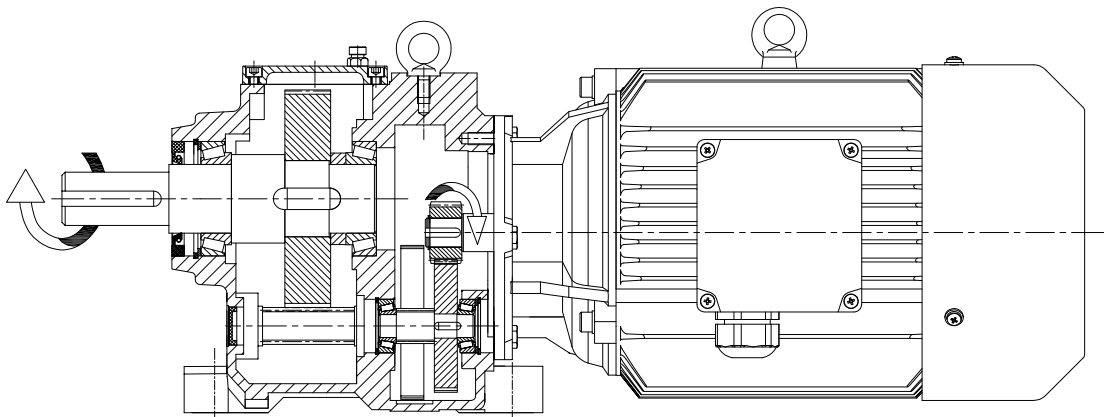

3-stage

### 3 Mounting Positions

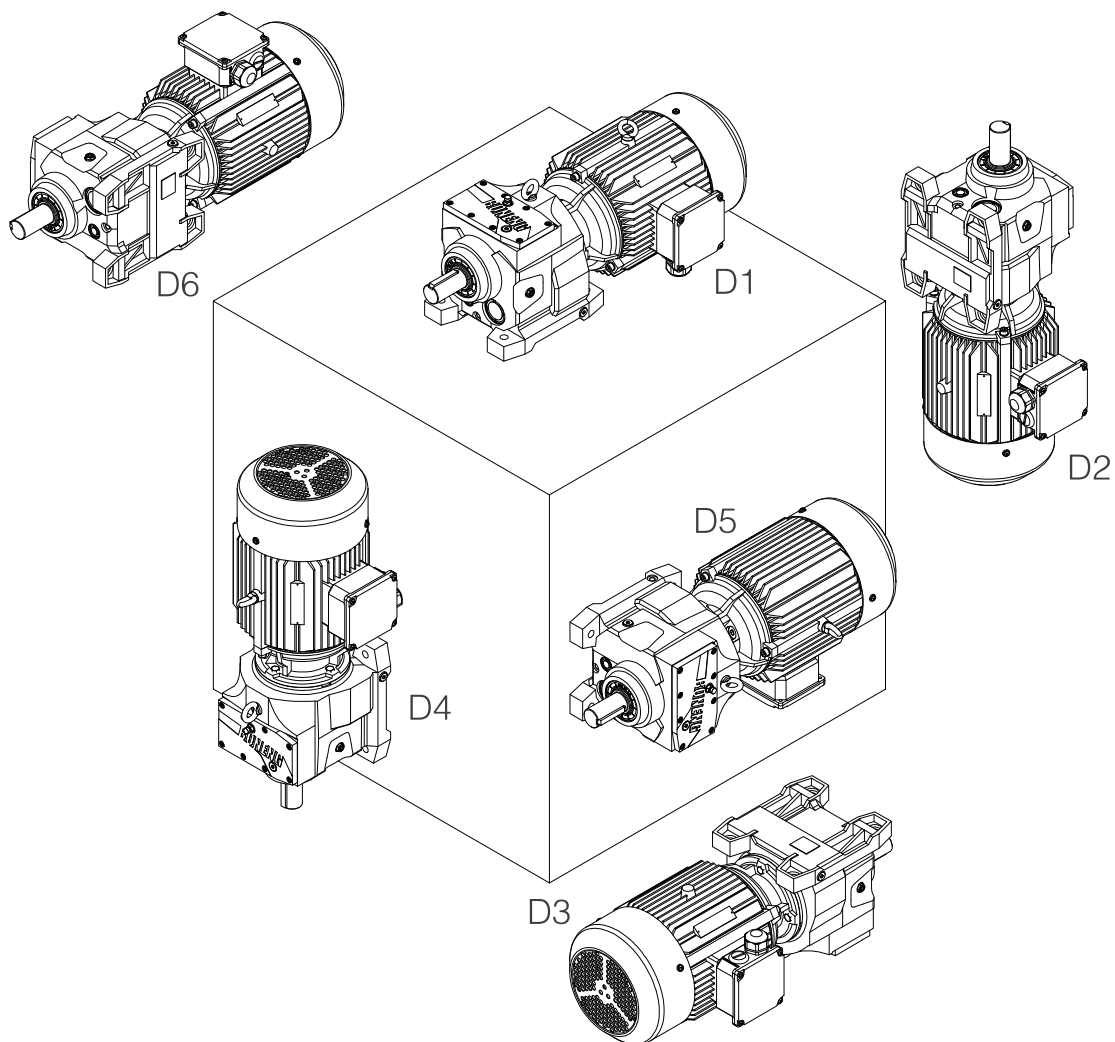

Motor terminal box and cable entry position ( View :Motor afterbody )

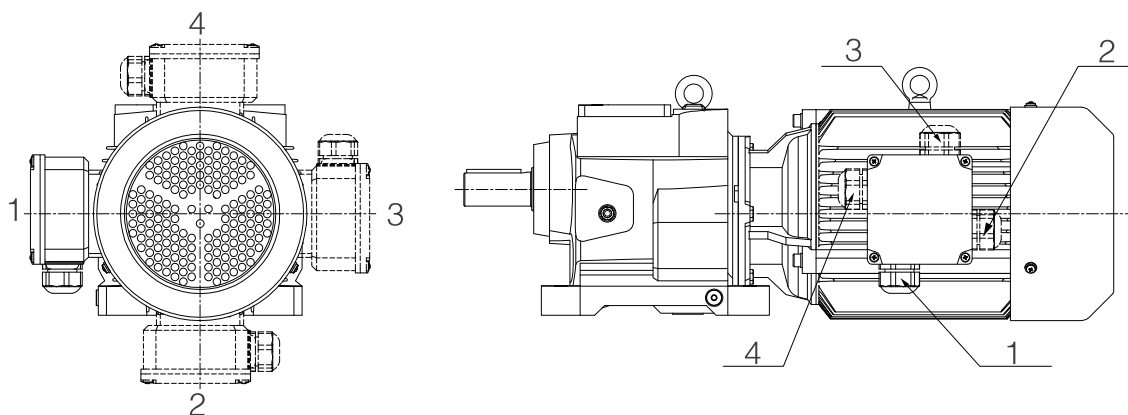

Assembly colour of gearmotor  ( RAL5015 )



## 4 Type Selection and Example

Step	Description	Symbol	Parameters Calculation and Guideline			
1	Driven Machine Factor	$f_1$	Load Characteristic	Operating hours per day (h)		
				$\leq 2$	2~10	10~24
			Uniform	1.00(1.00)	1.00(1.25)	1.25(1.50)
			Moderate	1.00(1.25)	1.25(1.50)	1.50(1.75)
			Heavy	1.25(1.50)	1.50(1.75)	1.75(2.00)
			Note: Apply values in the brackets when starts per hour are 10 times or more.			
2	Input Speed	$n_1$	$\leq 1800\text{rpm}$ Consult us if higher speed required.			
3	Calculation of the Ratio	$i$	$i=n_1/n_2$ ( $n_2$ : Output speed )			
4	Transmission Efficiency	$\eta$	C2.. 2-stage: 96% C3.. 3-stage: 94%			
5	Calculation of the input power of the gearunit on basis of the torque and power required by the driven machine.	$P_1$	$P_1=T_2 \cdot n_1/(9550 \cdot i \cdot \eta)$ or $P_1=P_2/\eta$			
6	Determination of gearunit type referring to the table of transmission capacity after calculation, For directly-connected motor, require to refer to directly-connected motor power table.	$T_{2N}$ 、 $P_{1N}$	$T_{2N} \geq T_2 \cdot f_1$ or $P_{1N} \geq P_1 \cdot f_1$			
7	Check the radial and axial forces on the shafts.	$F_{r1}/F_{r2}$ $F_{a1}/F_{a2}$	See the table of Radial Force on Output Shaft ( $F_{r2}$ ) on P51			
8	Determination of Lubrication system	/	Generally Splash Lubrication			
9	Determination of Cooling System	/	Generally Air Cooling			
10	Determination of every item included in the Type Designation	/	For details about Type Designation, see P01			
11	Normal ambient conditions	/	Ambient temperature $-20$ to $40^\circ\text{C}$ , ample space, good ventilation, altitude not exceeding 1000m and common plant dust.			
12	Special ambient conditions	/	For higher or lower temperature, dusty sites, chemical reaction (acids, alkaline, etc), or open field (sunlight, ice, rain, etc), please consult us!			

## Example

### ◆ Known Criteria:

- 1、 Load characteristics by the driven machine: Moderate, working 6 hours/d and starting 5 times/h;
- 2、 Normal motor: 4-pole, speed  $n_1=1450\text{r/min}$ ;
- 3、 The power required  $P_2=1.6\text{kW}$ , speed  $n_2=26\text{ r/min}$ ;
- 4、 Mounting mode: flange-mounted, mounting position D1, motor terminal box 1, cable entry position 1.

### ◆ Selection steps:

- 1、 By referring to the table of Load Characteristic, we get the driven machine factor  $f_1=1.25$ ;
- 2、 Calculation of the Ratio  $i_N$ :  
 $i = n_1 / n_2 = 1450 / 26 = 55.7$ , nominal ratio  $i_N = 56$ ;
- 3、 Calculation of the input power and determination of the motor power (transmission efficiency  $\eta = 94\%$ ):  
 $P_1 \geq P_2 / \eta = 1.6 / 0.94 = 1.7\text{kW}$ , so 2.2kW motor is selected.  
Refer to the directly-connected motor power table, it can be directly-connected;
- 4、 Determination of the nominal power of the geared motor  $P_{1N}$ :  
 $P_{1N} \geq P_2 \cdot f_1 / \eta = 1.6 \times 1.25 / 0.94 = 2.13\text{kW}$ ;
- 5、 The type selected:  
C307FA-C56-D100-MS100M4B22AL2-A0N00-011

## 5 Transmission Capacity

### 5.1 F Transmission capacity

C...(iN=3.15-280)

Nominal input Speed	Nominal output Speed	Nominal Ratio Code	Nominal Ratio	Rated Output Torque	Exact Ratio	Rated Input Power	Rated Output Torque	Exact Ratio	Rated Input Power	Rated Output Torque	Exact Ratio	Rated Input Power
$n_1$ (r/min)	$n_{2N}$ (r/min)	Code	$i_N$	$T_{2N}$ (N. m)	$i_{ex}$	$P_{1N}$ (kW)	$T_{2N}$ (N. m)	$i_{ex}$	$P_{1N}$ (kW)	$T_{2N}$ (N. m)	$i_{ex}$	$P_{1N}$ (kW)
				C200 C300			C201 C301			C203 C303		
$n_{1N}$ (r/min)	$n_{2N}$ (r/min)	Code	$i_N$	$T_{2N}$ (N. m)	$i_{ex}$	$P_{1N}$ (kW)	$T_{2N}$ (N. m)	$i_{ex}$	$P_{1N}$ (kW)	$T_{2N}$ (N. m)	$i_{ex}$	$P_{1N}$ (kW)
1450	460	B32	3.15	35	3.13	1.70						
	408	B36	3.55	35	3.43	1.55	50	3.37	2.26			
	363	B40	4	35	3.93	1.35	50	3.87	1.96	130	4.04	4.88
	322	B45	4.5	40	4.68	1.30	50	4.40	1.73	140	4.56	4.66
	290	B50	5	40	4.90	1.24	50	4.78	1.59	150	5.07	4.50
	259	B56	5.6	40	5.53	1.10	60	5.76	1.58	160	5.81	4.18
	230	B63	6.3	40	6.26	0.97	60	6.44	1.41	170	6.32	4.08
	204	B71	7.1	40	6.86	0.89	60	6.84	1.33	190	7.10	4.06
	181	B80	8	50	7.86	0.97	65	7.75	1.27	190	8.02	3.60
	161	B90	9	50	9.36	0.81	70	9.15	1.16	190	8.90	3.24
	145	C10	10	50	9.80	0.77	80	10.2	1.20	200	10.2	2.98
	129	C11	11.2	55	11.1	0.75	80	11.4	1.07	200	11.2	2.71
	116	C13	12.5	55	12.2	0.69	80	12.1	1.01	200	12.6	2.40
	104	C14	14	55	14.3	0.58	90	14.4	0.95	200	13.5	2.25
	90.6	C16	16	55	15.6	0.54	90	16.5	0.83	200	15.3	1.98
	80.6	C18	18	55	17.8	0.47	90	18.8	0.73	200	17.3	1.76
	72.5	C20	20	55	20.2	0.41	90	20.4	0.67	200	19.7	1.54
	64.7	C22	22.4	55	22.2	0.38	90	22.2	0.62	200	22.2	1.37
	58.0	C25	25	50	25.0	0.30	95	24.6	0.59	200	25.2	1.21
	51.8	C28	28	50	28.6	0.27	95	27.5	0.52	200	26.9	1.13
	46.0	C32	31.5	50	31.1	0.24	95	32.3	0.45	200	30.3	1.00
	40.8	C36	35.5	50	35.4	0.21	85	35.4	0.36	200	34.5	0.88
	36.3	C40	40	50	40.6	0.19	85	38.4	0.34	200	39.1	0.78
	32.2	C45	45	50	45.9	0.17	85	46.3	0.28	200	44.2	0.69
	29.0	C50	50	50	50.5	0.15	85	51.8	0.25	200	47.6	0.64
	25.9	C56	56	50	55.8	0.14	85	55.0	0.23	200	55.7	0.54
	23.0	C63	63	50	63.5	0.12	85	60.8	0.21	200	63.2	0.48
	20.4	C71	71	50	68.7	0.11	85	71.3	0.18	200	69.6	0.44
18.1	C80	80					85	81.0	0.16	200	76.1	0.40
16.1	C90	90					85	87.4	0.15	200	83.2	0.36
14.5	D10	100										
12.9	D11	112										
11.6	D13	125										
10.4	D14	140										
9.06	D16	160										
8.06	D18	180										
7.25	D20	200										
6.47	D22	224										
5.80	D25	250										
5.18	D28	280										
960	15.2	C63	63							200	63.2	0.32
	13.5	C71	71							200	69.6	0.29
	12.0	C80	80							200	76.1	0.26
	10.7	C90	90							200	83.2	0.24
	9.6	D10	100									
	8.54	D11	112									
	7.68	D13	125									
	6.89	D14	140									
	6	D16	160									
	5.34	D18	180									
	4.80	D20	200									
	4.28	D22	224									
3.84	D25	250										
3.43	D28	280										

Note:(1) Above the red line are two-stage transmission gearmotor models,model name C2...; Below the red line are three-stage transmission gearmotor models,model name C3...;  
(2) Actual output speed of the gearmotor: Actual input speed ( $n_1$ )/Exact ratio ( $i_{ex}$ );  
(3) Rated input power corresponding to actual input speed of the gearmotor:  $P_{1N}=T_{2N}*n_1/ ( 9550*i_{ex})$ ,the rated output torque  $T_{2N}$  in the formula remains unchanged.

Rated Output Torque	Exact Ratio	Rated Input Power	Rated Output Torque	Exact Ratio	Rated Input Power	Rated Output Torque	Exact Ratio	Rated Input Power	Rated Output Torque	Exact Ratio	Rated Input Power
$T_{2N}$ (N. m)	$i_{ex}$	$P_{1N}$ (kW)	$T_{2N}$ (N. m)	$i_{ex}$	$P_{1N}$ (kW)	$T_{2N}$ (N. m)	$i_{ex}$	$P_{1N}$ (kW)	$T_{2N}$ (N. m)	$i_{ex}$	$P_{1N}$ (kW)
C204 C304			C205 C305			C206 C306			C207 C307		
$T_{2N}$ (N. m)	$i_{ex}$	$P_{1N}$ (kW)	$T_{2N}$ (N. m)	$i_{ex}$	$P_{1N}$ (kW)	$T_{2N}$ (N. m)	$i_{ex}$	$P_{1N}$ (kW)	$T_{2N}$ (N. m)	$i_{ex}$	$P_{1N}$ (kW)
180	4.16	6.6							700	3.89	27.3
180	4.67	5.9	360	4.47	12.2	420	4.54	14.0	700	4.43	24.0
200	5.27	5.8	360	5.13	10.7	420	5.20	12.3	700	4.92	21.6
220	5.85	5.7	380	5.83	9.9	430	5.55	11.8	700	5.64	18.9
220	6.70	4.98	380	6.52	8.9	430	6.40	10.2	700	6.34	16.8
220	7.37	4.53	380	7.25	8.0	480	7.33	9.9	700	7.14	14.9
235	8.20	4.35	380	7.98	7.2	480	7.82	9.3	700	8.13	13.1
250	9.21	4.12	390	9.06	6.5	480	8.59	8.5	700	9.01	11.8
250	10.4	3.65	390	9.66	6.1	480	9.85	7.4	700	10.3	10.3
250	11.5	3.29	430	10.8	6.0	480	10.5	6.9	750	11.6	9.8
270	13.2	3.10	430	12.0	5.4	520	12.5	6.3	800	12.6	9.6
270	14.5	2.82	430	15.0	4.35	520	13.9	5.7	800	14.5	8.4
300	16.4	2.78	430	16.4	3.98	550	15.3	5.5	800	15.4	7.9
300	17.5	2.60	430	18.7	3.50	550	17.4	4.80	800	17.7	6.9
300	19.3	2.35	430	19.9	3.29	550	19.0	4.39	900	20.7	6.6
300	21.8	2.09	470	22.4	3.18	600	21.6	4.21	900	23.2	5.9
300	24.9	1.83	470	25.2	2.84	650	24.3	4.06	900	26.5	5.1
300	28.1	1.62	470	28.4	2.51	650	27.3	3.61	900	28.3	4.83
300	31.8	1.43	470	31.5	2.26	650	30.8	3.20	900	32.4	4.21
300	34.3	1.33	480	36.1	2.02	650	34.2	2.88	900	36.9	3.71
300	38.2	1.19	480	39.7	1.84	650	39.2	2.52	900	38.0	3.59
300	43.0	1.06	480	47.1	1.55	650	43.0	2.29	900	43.6	3.14
300	49.0	0.93	480	52.3	1.39	650	48.3	2.04	900	49.5	2.76
300	55.4	0.82	480	59.9	1.22	650	54.6	1.81	900	55.4	2.47
300	62.8	0.73	480	65.8	1.11	650	60.6	1.63	900	61.7	2.22
300	67.6	0.67	480	74.2	0.98	650	69.4	1.42	900	67.8	2.02
300	79.1	0.58	480	79.3	0.92	650	76.3	1.29	900	77.0	1.77
300	89.7	0.51	480	92.2	0.79	650	86.0	1.15	900	95.8	1.43
300	98.9	0.46	480	103.7	0.70	650	91.9	1.07	900	101.8	1.34
300	108.1	0.42	480	113.3	0.64	650	106.8	0.92	900	117.7	1.16
300	118.2	0.39	480	124.2	0.59	650	120.2	0.82	900	124.5	1.10
			480	135.0	0.54	650	131.2	0.75	900	140.0	0.98
						650	144.0	0.69	900	148.9	0.92
									900	168.2	0.81
300	62.8	0.48									
300	67.6	0.44									
300	79.1	0.38	480	79.3	0.61	650	76.3	0.85	900	77.0	1.17
300	89.7	0.34	480	92.2	0.52	650	86.0	0.76	900	95.8	0.95
300	98.9	0.30	480	103.7	0.46	650	91.9	0.71	900	101.8	0.89
300	108.1	0.28	480	113.3	0.42	650	106.8	0.61	900	117.7	0.77
300	118.2	0.26	480	124.2	0.39	650	120.2	0.54	900	124.5	0.73
			480	135.0	0.36	650	131.2	0.50	900	140.0	0.65
						650	144.0	0.46	900	148.9	0.61
									900	168.2	0.54

## C Transmission capacity

C...(iN=3.15-280)

Nominal input Speed	Nominal output Speed	Nominal Ratio Code	Nominal Ratio	Rated Output Torque	Exact Ratio	Rated Input Power	Rated Output Torque	Exact Ratio	Rated Input Power	Rated Output Torque	Exact Ratio	Rated Input Power
$n_1$ (r/min)	$n_{2N}$ (r/min)	Code	$i_N$	$T_{2N}$ (N.m)	$i_{ex}$	$P_{1N}$ (kW)	$T_{2N}$ (N.m)	$i_{ex}$	$P_{1N}$ (kW)	$T_{2N}$ (N.m)	$i_{ex}$	$P_{1N}$ (kW)
				C208 C308			C209 C309			C210 C310		
$n_{1N}$ (r/min)	$n_{2N}$ (r/min)	Code	$i_N$	$T_{2N}$ (N.m)	$i_{ex}$	$P_{1N}$ (kW)	$T_{2N}$ (N.m)	$i_{ex}$	$P_{1N}$ (kW)	$T_{2N}$ (N.m)	$i_{ex}$	$P_{1N}$ (kW)
1450	460	B32	3.15									
	408	B36	3.55									
	363	B40	4				1900	3.99	72	3300	3.87	130
	322	B45	4.5	1300	4.50	43.9	1900	4.37	66	3300	4.33	116
	290	B50	5	1300	5.11	38.6	1900	5.16	56	3300	5.11	98
	259	B56	5.6	1300	5.47	36.1	1900	5.78	49.9	3300	5.54	90
	230	B63	6.3	1300	6.46	30.5	1900	6.18	46.7	3800	6.47	89
	204	B71	7.1	1300	7.27	27.2	2200	7.06	47.3	4100	7.17	87
	181	B80	8	1300	7.97	24.8	2200	7.85	42.5	4300	7.60	86
	161	B90	9	1300	9.20	21.4	2200	8.91	37.5	4300	8.64	76
	145	C10	10	1300	10.4	19.0	2200	10.1	33.0	4300	9.67	68
	129	C11	11.2	1300	11.3	17.4	2300	11.4	30.7	4300	10.7	61
	116	C13	12.5	1300	12.7	15.5	2300	12.1	28.8	4300	12.5	52
	104	C14	14	1300	13.9	14.2	2500	13.9	27.4	4400	13.8	48.4
	90.6	C16	16	1500	16.1	14.1	2500	15.4	24.6	4400	14.6	45.6
	80.6	C18	18	1500	17.2	13.3	2650	17.5	23.0	4400	16.6	40.1
	72.5	C20	20	1500	20.0	11.4	2650	19.6	20.5	4400	18.6	35.9
	64.7	C22	22.4	1500	22.1	10.3	2850	22.4	19.3	4500	20.7	33.0
	58.0	C25	25	1700	25.4	10.2	2850	23.9	18.1	4500	24.3	28.1
	51.8	C28	28	1800	28.6	9.6	3000	27.9	16.4	4500	26.6	25.7
	46.0	C32	31.5	1800	31.7	8.6	3200	32.3	15.0	4500	31.5	21.7
	40.8	C36	35.5	1800	36.4	7.5	3200	35.2	13.8	4500	35.2	19.4
	36.3	C40	40	1800	41.0	6.7	3200	39.6	12.3	4500	37.6	18.2
	32.2	C45	45	1800	44.0	6.2	3200	43.4	11.2	4500	43.1	15.9
	29.0	C50	50	1800	50.1	5.5	3200	50.1	9.7	4500	47.9	14.3
	25.9	C56	56	1800	55.6	4.92	3200	53.5	9.1	4500	54.3	12.6
	23.0	C63	63	1800	63.8	4.29	3200	63.4	7.7	4500	67.9	10.1
	20.4	C71	71	1800	71.7	3.81	3200	69.1	7.0	4500	72.5	9.4
	18.1	C80	80	1800	80.2	3.41	3200	77.8	6.2	4500	82.9	8.2
	16.1	C90	90	1800	89.3	3.06	3200	85.2	5.7	4500	92.2	7.4
	14.5	D10	100	1800	97.8	2.79	3200	98.5	4.93	4500	104.5	6.5
	12.9	D11	112	1800	106.4	2.57	3200	105.0	4.63	4500	117.2	5.8
11.6	D13	125	1800	119.6	2.29	3200	121.3	4.01	4500	133.8	5.1	
10.4	D14	140	1800	131.0	2.09	3200	137.9	3.52	4500	142.6	4.79	
9.06	D16	160	1800	153.8	1.78	3200	153.2	3.17	4500	163.8	4.17	
8.06	D18	180	1800	170.9	1.60	3200	172.3	2.82	4500	184.3	3.71	
7.25	D20	200	1800	188.0	1.45	3200	189.6	2.56	4500	203.5	3.36	
6.47	D22	224				3200	207.1	2.35	4500	228.9	2.99	
5.80	D25	250				3200	239.9	2.03				
5.18	D28	280				3200	264.6	1.84				
960	15.2	C63	63									
	13.5	C71	71									
	12.0	C80	80									
	10.7	C90	90									
	9.6	D10	100	1800	97.8	1.85	3200	98.5	3.26	4500	104.5	4.30
	8.54	D11	112	1800	106.4	1.70	3200	105.0	3.07	4500	117.2	3.84
	7.68	D13	125	1800	119.6	1.52	3200	121.3	2.65	4500	133.8	3.38
	6.89	D14	140	1800	131.0	1.38	3200	137.9	2.33	4500	142.6	3.17
	6	D16	160	1800	153.8	1.18	3200	153.2	2.10	4500	163.8	2.76
	5.34	D18	180	1800	170.9	1.06	3200	172.3	1.87	4500	184.3	2.46
	4.80	D20	200	1800	188.0	0.96	3200	189.6	1.69	4500	203.5	2.22
	4.28	D22	224				3200	207.1	1.56	4500	228.9	1.98
	3.84	D25	250				3200	239.9	1.34			
3.43	D28	280				3200	264.6	1.22				

Note:(1) Above the red line are two-stage transmission gearmotor models,model name C2...; Below the red line are three-stage transmission gearmotor models,model name C3...;  
 (2) Actual output speed of the gearmotor: Actual input speed (n1)/Exact ratio (iex);  
 (3) Rated input power corresponding to actual input speed of the gearmotor: P1N=T2N\*n1/ ( 9550\*iex),the rated output torque T2N in the formula remains unchanged.

Rated Output Torque	Exact Ratio	Rated Input Power	Rated Output Torque	Exact Ratio	Rated Input Power	Rated Output Torque	Exact Ratio	Rated Input Power	Rated Output Torque	Exact Ratio	Rated Input Power
$T_{2N}$ (N. m)	$i_{ex}$	$P_{1N}$ (kW)	$T_{2N}$ (N. m)	$i_{ex}$	$P_{1N}$ (kW)	$T_{2N}$ (N. m)	$i_{ex}$	$P_{1N}$ (kW)	$T_{2N}$ (N. m)	$i_{ex}$	$P_{1N}$ (kW)
C212 C312			C213 C313			C214 C314			C216 C316		
$T_{2N}$ (N. m)	$i_{ex}$	$P_{1N}$ (kW)	$T_{2N}$ (N. m)	$i_{ex}$	$P_{1N}$ (kW)	$T_{2N}$ (N. m)	$i_{ex}$	$P_{1N}$ (kW)	$T_{2N}$ (N. m)	$i_{ex}$	$P_{1N}$ (kW)
			5000	4.07	187	10000	4.00	380			
4300	4.37	149	5000	4.74	160	10000	4.47	340	16000	4.42	549
4300	4.89	134	5300	5.26	153	10000	4.97	305	16000	4.99	487
4300	5.77	113	5300	5.87	137	10000	5.60	271	16000	5.76	422
4600	6.26	112	5600	6.48	131	10000	6.45	235	16000	6.57	370
5100	7.31	106	6000	7.03	130	10000	7.12	213	16000	7.04	345
5600	8.10	105	8000	8.08	150	13000	7.89	250	17000	7.61	339
5800	8.59	103	8000	9.15	133	13000	8.74	226	17000	8.80	293
5800	9.8	90	8000	10.5	115	13000	9.77	202	17000	10.1	255
5800	10.8	82	8000	11.7	103	13000	10.9	182	17000	11.6	223
5800	12.6	70	8000	13.0	94	13000	12.2	161	17000	12.4	209
5800	14.0	63	8000	14.1	86	13000	14.1	140	17000	13.4	193
5800	16.9	52	8000	16.2	75	13000	15.6	127	18000	15.5	177
5800	18.9	46.6	8000	18.3	66	13000	17.3	114	18000	17.3	158
5800	19.1	46.2	8000	20.4	60	13000	19.2	103	18000	19.5	140
5800	20.9	42.2	8000	22.6	54	13000	21.8	91	18000	21.5	127
6000	24.7	36.9	8000	25.1	48.3	13000	24.2	82	18000	24.2	113
6300	27.7	34.6	8000	29.4	41.4	13000	29.5	67	18000	27.2	100
6300	30.1	31.8	8200	32.5	38.3	14000	32.7	65	18000	30.3	90
6300	35.5	26.9	8200	35.1	35.5	14000	36.5	58	18000	34.2	80
6300	39.8	24.0	8200	39.3	31.7	14000	40.3	53	18000	39.4	69
6300	42.5	22.5	8200	46.4	26.8	14000	43.7	48.6	18000	43.4	63
6300	48.6	19.7	8200	50.3	24.7	14000	50.3	42.3	18000	48.1	57
6300	54.1	17.7	8200	58.7	21.2	14000	55.3	38.4	18000	53.5	51
6300	61.3	15.6	8200	65.1	19.1	14000	64.5	33.0	18000	60.8	45.0
6300	73.5	13.0	8000	69.0	17.6	14000	71.6	29.7	18000	69.2	39.5
6300	84.0	11.4	8000	78.5	15.5	14000	79.8	26.6	18000	76.3	35.8
6300	93.4	10.2	8000	87.8	13.8	13500	88.1	23.3	18000	84.5	32.3
6300	105.9	9.03	8000	97.5	12.5	13500	95.6	21.4	18000	94.1	29.1
6300	118.7	8.06	8200	114.1	10.9	13500	109.9	18.6	18000	106.7	25.6
6300	135.5	7.06	8200	122.7	10.1	13500	124.5	16.5	18000	118.6	23.1
6300	144.4	6.62	8200	137.9	9.0	13500	138.6	14.8	18000	134.7	20.3
6300	166.0	5.76	8200	158.7	7.8	13500	153.4	13.4	18000	154.6	17.7
6300	186.7	5.12	8200	176.6	7.1	13500	179.1	11.4	18000	174.8	15.6
6300	206.3	4.64	8200	207.7	6.0	13500	190.0	10.8	18000	191.9	14.2
6300	231.9	4.12	8200	225.4	5.5	14000	215.5	9.9	18000	212.0	12.9
6300	252.4	3.79				14000	245.9	8.6			
6300	274.2	3.49				14000	276.7	7.7			
6300	105.9	6	8000	97.5	8.3						
6300	118.7	5.3	8200	114.1	7.2						
6300	135.5	4.67	8200	122.7	6.7						
6300	144.4	4.38	8200	137.9	6.0						
6300	166.0	3.81	8200	158.7	5.2	13500	153.4	8.9	18000	154.6	11.7
6300	186.7	3.39	8200	176.6	4.70	13500	179.1	7.6	18000	174.8	10.3
6300	206.3	3.07	8200	207.7	3.97	13500	190.0	7.2	18000	191.9	9.4
6300	231.9	2.73	8200	225.4	3.64	14000	215.5	6.6	18000	212.0	8.5
6300	252.4	2.51				14000	245.9	5.7			
6300	274.2	2.31				14000	276.7	5.1			

## 5.2 C.../C... Combi-type transmission capacity

C.../C... (i<sub>N</sub>=100-18000)

Nominal input Speed	Nominal output Speed	Nominal Ratio Code	Nominal Ratio	Rated Output Torque	Exact Ratio	Rated Input Power	Rated Output Torque	Exact Ratio	Rated Input Power	
n <sub>1</sub> (r/min)	n <sub>2N</sub> (r/min)	Code	i <sub>N</sub>	T <sub>2N</sub> (N·m)	i <sub>ex</sub>	P <sub>1N</sub> (kW)	T <sub>2N</sub> (N·m)	i <sub>ex</sub>	P <sub>1N</sub> (kW)	
1450	14.50	D10	100	200	97.70	0.31	270	105.9	0.39	
	12.90	D11	112	200	115.3	0.26	270	117.5	0.35	
	11.60	D13	125	200	128.5	0.24	270	134.6	0.30	
	10.36	D14	140	200	143.6	0.21	270	147.8	0.28	
	9.06	D16	160	200	152.5	0.20	270	166.3	0.25	
					C203/C201			C204/C203		
	8.06	D18	180	200	181.4	0.17	270	178.2	0.23	
					C203/C301			C204/C303		
	7.25	D20	200	200	207.9	0.15	270	202.0	0.20	
	6.47	D22	224	200	236.9	0.13	270	228.4	0.18	
					C303/C201			C304/C203		
	5.80	D25	250	200	236.0	0.13	300	243.5	0.19	
	5.18	D28	280	200	267.4	0.11	300	275.1	0.17	
	4.60	D32	315	200	315.7		300	305.3	0.15	
	4.08	D36	355	200	351.9		300	349.9	0.13	
	3.63	D40	400	200	393.3		300	384.2	0.12	
	3.22	D45	450	200	417.5		300	432.2	0.11	
					C303/C301			C304/C303		
	2.90	D50	500	200	496.8		300	463.1		
					C303/C301			C304/C303		
	2.59	D56	560	200	569.3		300	524.8		
	2.30	D63	630	200	648.6		300	593.4		
	2.04	D71	710	200	703.8		300	675.7		
	1.81	D80	800	200	765.9		300	761.5		
	1.61	D90	900	200	848.7		300	864.4		
	1.45	E10	1000	200	948.8		300	922.7		
	1.29	E11	1120	200	1114		300	1039		
	1.16	E13	1250	200	1221		300	1183		
	1.04	E14	1400	200	1325		300	1341		
	0.91	E16	1600	200	1597		300	1516		
	0.81	E18	1800	200	1787		300	1633		
	0.73	E20	2000	200	1898		300	1911		
	0.65	E22	2240	200	3843		300	2168		
	0.58	E25	2500	200	2427		300	2455		
	0.52	E28	2800	200	2926		300	2776		
	0.46	E32	3150	200	3274		300	2989		
	0.41	E36	3550	200	3476		300	3498		
	0.36	E40	4000	200	3843		300	3969		
	0.32	E45	4500	200	4506		300	4371		
	0.29	E50	5000	200	5119		300	4779		
	0.26	E56	5600	200	5524		300	5225		
	0.23	E63	6300				300	6243		
	0.20	E71	7100				300	6826		
	0.18	E80	8000				300	7463		
	0.16	E90	9000							
0.15	F10	10000								
0.13	F11	11200								
0.12	F13	12500								
0.10	F14	14000								
0.09	F16	16000								
0.08	F18	18000								

Rated Output Torque	Exact Ratio	Rated Input Power	Rated Output Torque	Exact Ratio	Rated Input Power	Rated Output Torque	Exact Ratio	Rated Input Power
$T_{2N}$ (N · m)	i <sub>ex</sub>	$P_{1N}$ (kW)	$T_{2N}$ (N · m)	i <sub>ex</sub>	$P_{1N}$ (kW)	$T_{2N}$ (N · m)	i <sub>ex</sub>	$P_{1N}$ (kW)
C205/C203			C206/C203			C307/C203		
430	96.2	0.68	520	100.3	0.79	800	101.1	1.20
430	106.8	0.61	520	111.3	0.71	800	112.1	1.08
430	122.4	0.53	520	127.5	0.62	800	128.5	0.95
430	134.4	0.49	520	140.0	0.56	800	141.1	0.86
430	151.2	0.43	520	157.5	0.50	800	158.8	0.77
430	162.0	0.40	520	168.8	0.47	800	170.1	0.71
C205/C303			C206/C303			C307/C303		
430	183.6	0.36	520	191.3	0.41	800	192.8	0.63
430	207.6	0.31	520	216.3	0.37	800	218.0	0.56
C305/C203			C306/C203			C307/C203		
480	256.3	0.28	650	242.8	0.41	900	262.0	0.52
480	289.5	0.25	650	274.3	0.36	900	295.9	0.46
480	321.3	0.23	650	304.4	0.32	900	328.4	0.42
480	368.2	0.20	650	348.8	0.28	900	376.4	0.36
480	404.3	0.18	650	383.0	0.26	900	413.3	0.33
480	454.9	0.16	650	430.9	0.23	900	464.9	0.29
480	487.4	0.15	650	461.7	0.21	900	498.2	0.27
C305/C303			C306/C303			C307/C303		
480	552.3	0.13	650	523.3	0.19	900	564.6	0.24
480	624.5	0.12	650	591.7	0.17	900	638.4	0.21
480	711.2	0.10	650	673.7	0.15	900	726.9	0.19
480	801.4		650	759.2	0.13	900	819.2	0.17
480	909.7		650	861.8	0.11	900	929.9	0.15
480	971.1		650	920.0		900	992.6	0.14
480	1094		650	1036		900	1118	0.12
480	1245		650	1180		900	1273	0.11
480	1412		650	1337		900	1443	
480	1596		650	1512		900	1631	
480	1718		650	1628		900	1756	
480	2011		650	1905		900	2055	
480	2282		650	2161		900	2332	
480	2573		570	2369		900	2412	
480	2908		570	2679		900	2727	
480	3132		570	2885		900	2937	
480	3665		570	3375		900	3437	
480	4159		570	3830		900	3899	
480	4580		570	4218		900	4294	
480	5007		570	4612		900	4695	
480	5475		570	5042		900	5133	
480	6417		570	5979		900	6668	
480	7016		570	6537		800	7290	
480	7671		570	7147		800	7971	



### C.../C... Combi-type transmission capacity

C.../C... (  $i_N=100-18000$  )

Nominal input Speed	Nominal output Speed	Nominal Ratio Code	Nominal Ratio	Rated Output Torque	Exact Ratio	Rated Input Power	Rated Output Torque	Exact Ratio	Rated Input Power	Rated Output Torque	Exact Ratio	Rated Input Power	
$n_1$ (r/min)	$n_{2N}$ (r/min)	Code	$i_N$	$T_{2N}$ (N·m)	$i_{ex}$	$P_{1N}$ (kW)	$T_{2N}$ (N·m)	$i_{ex}$	$P_{1N}$ (kW)	$T_{2N}$ (N·m)	$i_{ex}$	$P_{1N}$ (kW)	
1450	14.50	D10	100	1300	101.3	1.95	2300	96.6	3.62	4300	101.6	6.42	
	12.90	D11	112	1300	115.1	1.72	2300	109.6	3.19	4300	112.6	5.80	
	11.60	D13	125	1300	122.7	1.61	2300	116.9	2.99	4300	128.8	5.07	
	10.36	D14	140	1300	137.2	1.44	2300	130.7	2.67	4300	145.0	4.50	
											C210/C307		
	9.06	D16	160	1300	152.4	1.30	2300	145.2	2.41	4300	157.5	4.15	
	8.06	D18	180	1300	190.5	1.04	2300	181.5	1.92	4300	181.3	3.60	
	7.25	D20	200	1300	208.3	0.95	2300	198.4	1.76	4300	192.5	3.39	
	6.47	D22	224	1300	237.5	0.83	2300	226.3	1.54	4300	221.3	2.95	
											C308/C205		
	5.80	D25	250	1800	263.9	1.04	3200	255.2	1.90	4500	251.3	2.72	
	5.18	D28	280	1800	290.5	0.94	3200	280.9	1.73	4500	286.2	2.39	
	4.60	D32	315	1800	329.8	0.83	3200	318.9	1.52	4500	317.2	2.15	
	4.08	D36	355	1800	351.6	0.78	3200	340.0	1.43	4500	362.6	1.88	
	3.63	D40	400	1800	393.1	0.70	3200	380.2	1.28	4500	408.3	1.67	
											C310/C207		
	3.22	D45	450	1800	436.8	0.63	3200	422.4	1.15	4500	443.5	1.54	
	2.90	D50	500	1800	546.0	0.50	3200	528.0	0.92	4500	510.4	1.34	
	2.59	D56	560	1800	597.0	0.46	3200	577.3	0.84	4500	542.1	1.26	
	2.30	D63	630	1800	680.7	0.40	3200	658.2	0.74	4500	623.0	1.10	
	2.04	D71	710	1800	724.4	0.38	3200	700.5	0.69	4500	728.6	0.94	
											C310/C307		
	1.81	D80	800	1800	815.4	0.34	3200	788.5	0.62	4500	816.6	0.84	
	1.61	D90	900	1800	917.3	0.30	3200	887.0	0.55	4500	932.8	0.73	
											C308/C305		
	1.45	E10	1000	1800	1034	0.26	3200	1000	0.49	4500	996.2	0.69	
	1.29	E11	1120	1800	1147	0.24	3200	1109	0.44	4500	1140	0.60	
	1.16	E13	1250	1800	1314	0.21	3200	1271	0.38	4500	1299	0.53	
	1.04	E14	1400	1800	1445	0.19	3200	1397	0.35	4500	1338	0.51	
	0.91	E16	1600	1800	1714	0.16	3200	1658	0.29	4500	1535	0.45	
	0.81	E18	1800	1800	1904	0.14	3200	1841	0.26	4500	1742	0.39	
	0.73	E20	2000	1800	2180	0.13	3200	2108	0.23	4500	1950	0.35	
	0.65	E22	2240	1800	2395	0.11	3200	2316	0.21	4500	2172	0.31	
	0.58	E25	2500	1800	2533		3200	2517	0.19	4500	2580	0.26	
	0.52	E28	2800	1800	3005		3200	2986	0.16	4500	2960	0.23	
	0.46	E32	3150	1800	3337		3200	3316	0.15	4500	3361	0.20	
	0.41	E36	3550	1800	3822		3200	3798	0.13	4500	3762	0.18	
	0.36	E40	4000	1800	4198		3200	4172	0.12	4500	4189	0.16	
	0.32	E45	4500	1800	4734		3200	4704	0.10	4500	4604	0.15	
	0.29	E50	5000	1800	5059		3200	5028		4500	5228	0.13	
	0.26	E56	5600	1800	5882		3200	5845		4500	6505	0.11	
	0.23	E63	6300	1800	6626		3200	6322		4500	6912		
	0.20	E71	7100	1500	7081		2800	6756		4500	7099		
	0.18	E80	8000	1500	8233		2800	7855		4500	8833		
	0.16	E90	9000	1500	9260		2800	8835		4500	9386		
	0.15	F10	10000	1500	10118		2800	9653		4500	10852		
	0.13	F11	11200	1500	11091		2800	10582		4500	11479		
	0.12	F13	12500	1500	12056		2800	11502		4500	12908		
0.10	F14	14000							4500	13729			
0.09	F16	16000							4500	15508			
0.08	F18	18000											

Rated Output Torque	Exact Ratio	Rated Input Power	Rated Output Torque	Exact Ratio	Rated Input Power	Rated Output Torque	Exact Ratio	Rated Input Power
$T_{2N}$ (N·m)	iex	$P_{1N}$ (kW)	$T_{2N}$ (N·m)	iex	$P_{1N}$ (kW)	$T_{2N}$ (N·m)	iex	$P_{1N}$ (kW)
C213/C207			C214/C208			C216/C210		
7300	105.7	10.49	14000	97.2	21.9	16000	94.2	25.8
7300	117.1	9.46	14000	112.2	18.9	16000	107.1	22.7
7300	133.9	8.28	14000	126.9	16.8	16000	119.9	20.3
7300	150.8	7.35	14000	137.9	15.4	16000	132.7	18.3
C213/C307								
7300	163.8	6.77	14000	154.9	13.7	16000	155.0	15.7
7300	188.5	5.88	14000	169.6	12.5	16000	171.1	14.2
7300	200.2	5.54	14000	196.4	10.8	16000	181.0	13.4
7300	230.1	4.82	14000	209.8	10.1	16000	205.8	11.8
C313/C207			C314/C207			C316/C209		
8200	250.6	4.97	14000	260.6	8.2	18000	241.5	11.3
8200	285.4	4.36	14000	296.7	7.2	18000	268.5	10.2
8200	316.3	3.94	14000	328.9	6.5	18000	304.7	9.0
8200	361.5	3.44	14000	376.0	5.7	18000	345.4	7.9
8200	407.2	3.06	14000	423.4	5.02	18000	389.9	7.0
C313/C307			C314/C307					
8200	442.3	2.82	14000	459.9	4.62	18000	413.8	6.6
8200	509.0	2.45	14000	529.3	4.02	18000	475.4	5.8
8200	540.5	2.30	14000	562.1	3.78	18000	526.7	5.2
8200	621.3	2.00	14000	646.1	3.29	18000	598.5	4.57
8200	726.6	1.71	14000	755.6	2.81	18000	670.3	4.08
8200	814.3	1.53	14000	846.8	2.51	18000	766.1	3.57
8200	930.2	1.34	14000	967.3	2.20	18000	817.4	3.34
						C316/C309		
8200	993.3	1.25	14000	1033	2.06	18000	954.2	2.86
8200	1137	1.09	14000	1183	1.80	18000	1105	2.47
8200	1295	0.96	14000	1347	1.58	18000	1204	2.27
8200	1334	0.93	14000	1387	1.53	18000	1354	2.02
8200	1530	0.81	14000	1591	1.34	18000	1484	1.84
8200	1737	0.72	14000	1807	1.18	18000	1713	1.60
8200	1945	0.64	14000	2022	1.05	18000	1830	1.49
8200	2166	0.57	14000	2252	0.94	18000	2168	1.26
8200	2474	0.50	14000	2451	0.87	18000	2408	1.14
8200	2838	0.44	14000	2812	0.76	18000	2639	1.04
8200	3222	0.39	14000	3193	0.67	18000	3046	0.90
8200	3607	0.35	14000	3573	0.59	18000	3253	0.84
8200	4017	0.31	14000	3980	0.53	18000	3855	0.71
8200	4414	0.28	14000	4373	0.49	18000	4201	0.65
8200	5013	0.25	14000	4967	0.43	18000	4730	0.58
8200	6237	0.20	14000	6179	0.34	18000	5180	0.53
8200	6627	0.19	14000	6566	0.32	18000	5839	0.47
8000	6761	0.18	13500	6784	0.30	17000	6574	0.39
8000	8411	0.14	13500	8440	0.24	17000	7199	0.36
8000	8938	0.14	13500	8969	0.23	17000	8323	0.31
8000	10334	0.12	13500	10369	0.20	17000	8873	0.29
8000	10931	0.11	13500	10968	0.19	17000	10250	0.25
8000	12292		13500	12334	0.17	17000	11653	0.22
8000	13073		13500	13118	0.16	17000	12945	0.20
8000	14768		13500	14818	0.14	17000	14559	0.18
						17000	16021	0.16

## 6 Dimensions

### C200/C300 Dimensions

**C200H  
C300H**

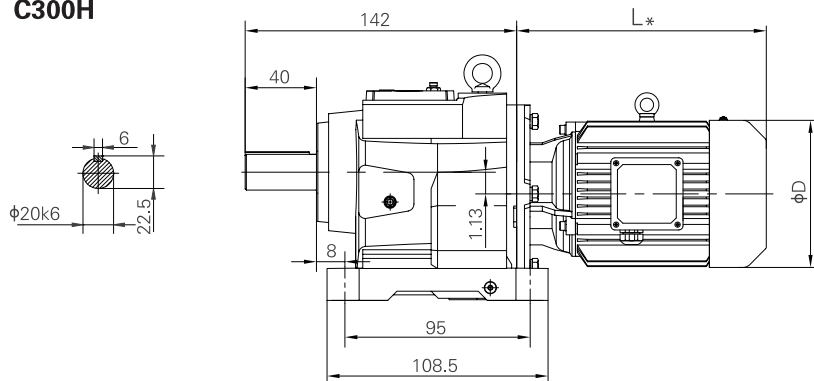

Horizontal foot-mounted

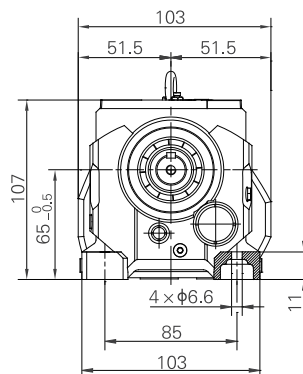

Weight: 4kg ( Without motor and oil )

**C200F  
C300F**

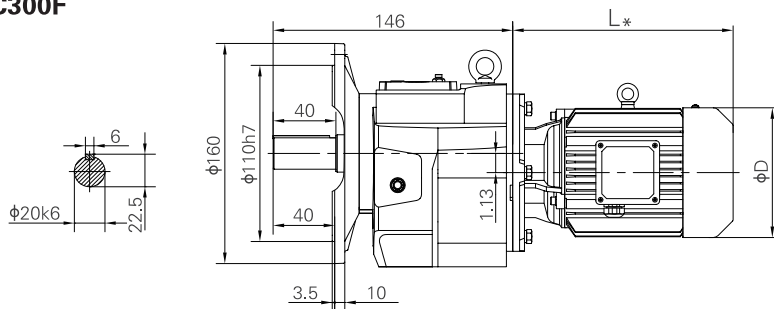

Flange-mounted

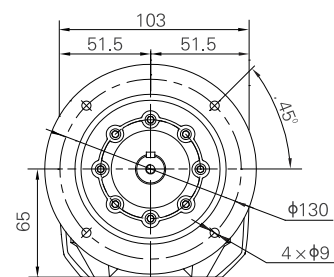

Weight: 5kg ( Without motor and oil )

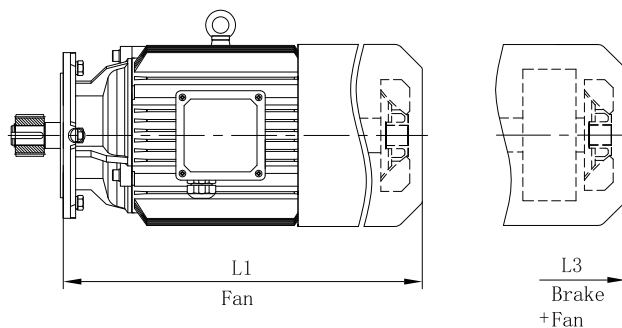

Directly connected motor dimension table										Directly connected motor weight table / kg						
4-pole power (kW)	Range of Ratio	MS		MH		MP		MA	D	MS		MH		MP		MA
		L1	L3	L1	L3	L1	L3	L1		M1	M3	M1	M3	M1	M3	M1
0.09	3.15-71	179	214	/	/	/	/	/	116	5	7	/	/	/	/	/
0.12	3.15-71	179	214	/	/	/	/	/	116	5	7	/	/	/	/	/
0.18	3.15-50	/	233	198	233	198	233	198	124	/	9	7	9	7	9	8
0.25	3.15-35.5	198	233	/	/	/	/	/	124	7	9	/	/	/	/	/
0.37	3.15-25	/	246	211	246	211	246	211	139	/	11	9	11	9	11	10

**C201/C301 Dimensions**

**C201H  
C301H**

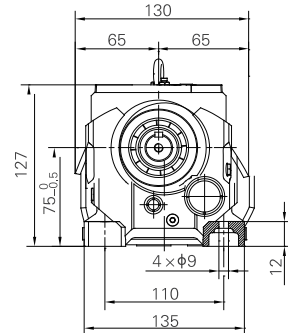
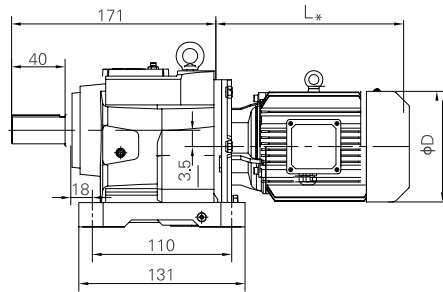
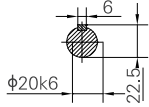

Horizontal foot-mounted

Weight: 7kg ( Without motor and oil )

**C201F  
C301F**

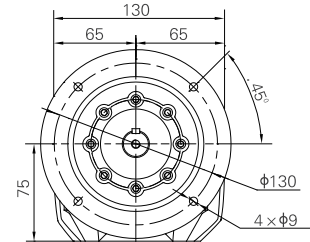
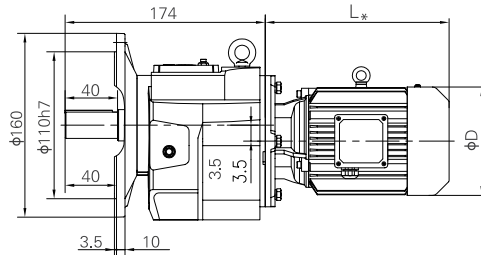
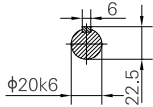

Flange-mounted

Weight: 8kg ( Without motor and oil )

**C201S  
C301S**

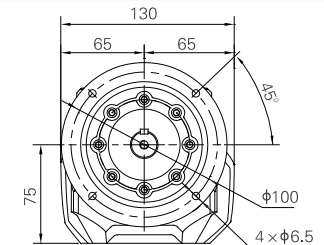
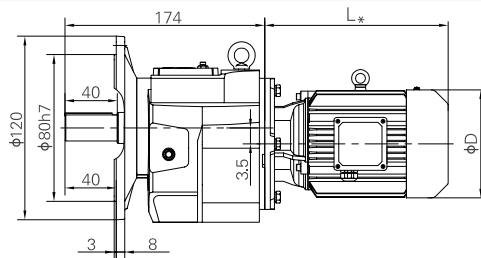
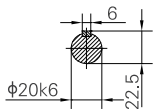

Short flange-mounted

Weight: 8kg ( Without motor and oil )

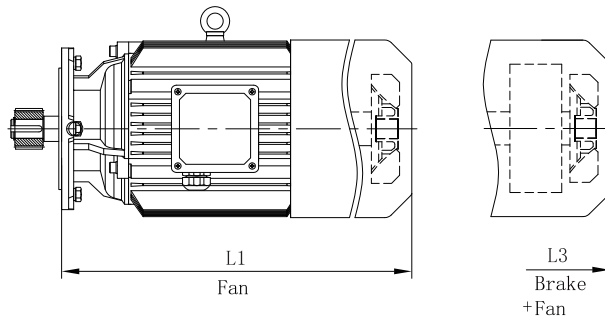

Directly connected motor dimension table

Directly connected motor weight table / kg

4-pole power (kW)	Range of Ratio	Directly connected motor dimension table								Directly connected motor weight table / kg						
		MS		MH		MP		MA	D	MS		MH		MP		MA
		L1	L3	L1	L3	L1	L3	L1		M1	M3	M1	M3	M1	M3	M1
0.12	3.55-90	/	241	206	241	206	241	206	124	/	9	7	9	7	9	7
0.18	3.55-90	/	241	206	241	206	241	206	124	/	9	7	9	7	9	8
0.25	3.55-63	206	241	/	/	/	/	/	124	7	9	/	/	/	/	/
0.37	3.55-40	/	253	218	253	218	253	218	139	/	11	9	11	9	11	10
0.55	3.55-31.5	218	253	/	/	/	/	/	139	9	11	/	/	/	/	/

**C203/C303 Dimensions**

**C203H  
C303H**

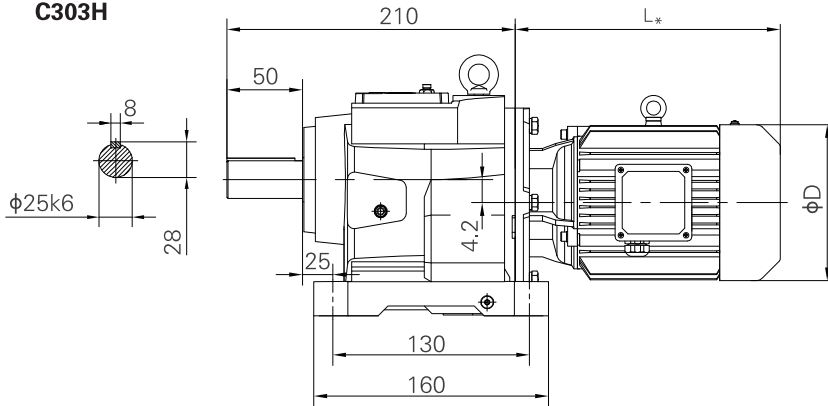

Horizontal foot-mounted

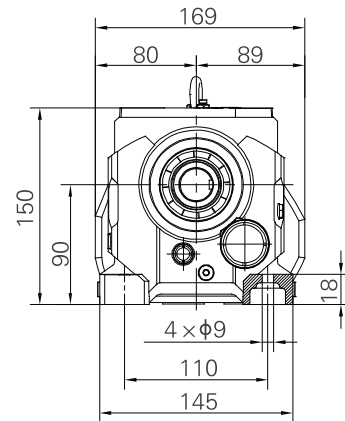

Weight: 8kg ( Without motor and oil )

**C203F  
C303F**

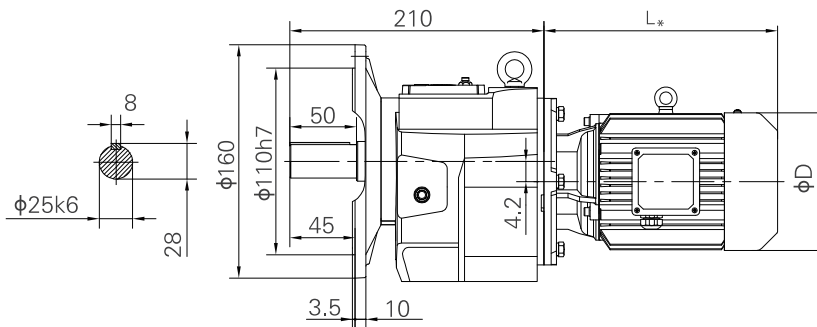

Flange-mounted

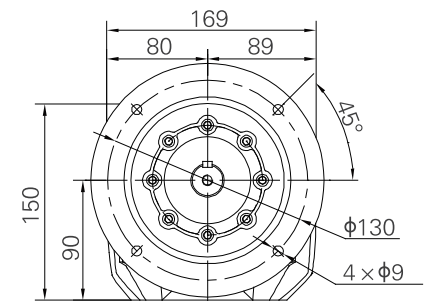

Weight: 9kg ( Without motor and oil )

**C203S  
C303S**

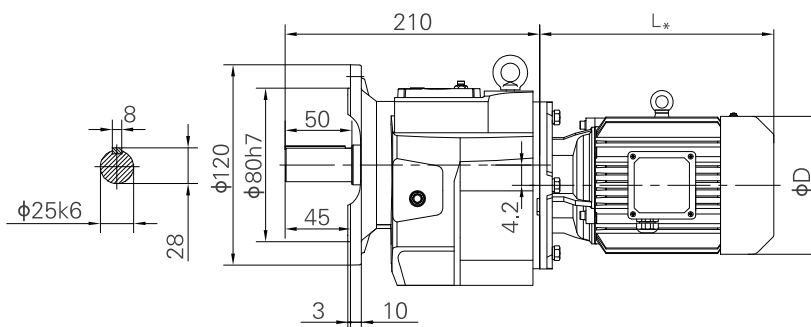

Short flange-mounted

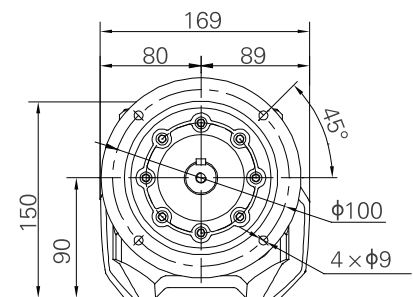

Weight: 9kg ( Without motor and oil )

**Corresponding motor dimension table for C203/C303**

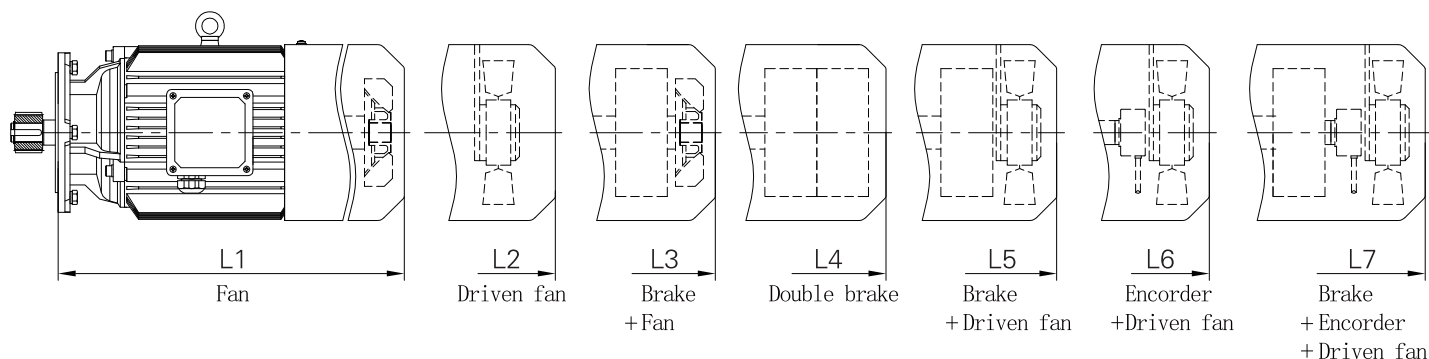

Directly connected motor dimension table

4-pole power (kW)	Range of Ratio	MS							MH							MP							MA							D
		L1	L2	L3	L4	L5	L6	L7	L1	L2	L3	L5	L6	L7	L1	L2	L3	L5	L6	L7	L1	L2	L3	L5	L6	L7				
0.12	4-90	/	261	241	/	296	/	/	206	261	241	296	/	/	206	261	241	296	/	/	206	261	241	296	/	/	124			
0.18	4-90	/	261	241	/	296	/	/	206	261	241	296	/	/	206	261	241	296	/	/	206	261	241	296	/	/	124			
0.25	4-90	/	268	263	/	313	313	353	223	268	263	313	313	353	223	268	263	313	313	353	223	273	263	318	318	358	139			
0.37	4-90	/	268	263	/	313	313	353	223	268	263	313	313	353	223	268	263	313	313	353	223	273	263	318	318	358	139			
0.55	4-71	299	344	359	419	404	404	454	299	344	359	404	404	454	299	344	359	404	404	454	299	344	359	404	404	449	162			
0.75	4-50	299	344	359	419	404	404	454	299	344	359	404	404	454	299	344	359	404	404	454	299	344	359	404	404	449	162			
1.1	4-35.5	322	367	377	437	422	422	477	322	367	377	422	422	477	322	367	377	422	422	477	347	392	402	452	452	497	176			
1.5	4-25	322	367	377	437	422	422	477	322	367	377	422	422	477	347	392	402	447	447	502	347	392	402	452	452	497	176			
2.2	4-18	394	434	469	529	509	509	564	394	434	469	509	509	564	394	434	469	509	509	564	394	449	469	529	529	574	202			
3	4-12.5	394	434	469	529	509	509	564	394	434	469	509	509	564	394	434	469	509	509	564	394	449	469	529	529	574	202			

Directly connected motor weight table / kg

4-pole power (kW)	Range of Ratio	MS							MH							MP							MA						
		M1	M2	M3	M4	M5	M6	M7	M1	M2	M3	M5	M6	M7	M1	M2	M3	M5	M6	M7	M1	M2	M3	M5	M6	M7			
0.12	4-90	/	8	9	/	9	/	/	7	8	9	9	/	/	7	8	9	9	/	/	7	7.5	8.5	9	/	/			
0.18	4-90	/	8	9	/	9	/	/	7	8	9	9	/	/	8	9	10	10	/	/	8	8.5	9.5	10	/	/			
0.25	4-90	/	9	10	/	11	10	12	8	9	10	11	10	12	9	10	11	12	11	13	9	10	10.5	11.5	10.5	12.5			
0.37	4-90	/	10	11	/	12	11	13	9	10	11	12	11	13	10	11	12	13	12	14	10	11	11.5	12.5	11.5	13.5			
0.55	4-71	13	14	17	21	18	15	19	14	15	18	12	16	20	15	16	19	20	17	21	15	16	19	20	16.5	21			
0.75	4-50	14	15	18	22	19	16	20	15	16	19	12	17	21	16	17	20	21	18	22	16	17	20	21	17.5	22			
1.1	4-35.5	16	17	20	24	21	18	22	18	19	22	12	20	24	21	22	25	26	23	27	21	22	25	26	22.5	27			
1.5	4-25	17	18	21	25	22	19	23	19	20	23	12	21	25	23	24	27	28	25	29	23	24	27	28	24.5	29			
2.2	4-18	27	28	35	42	36	29	37	30	31	38	12	32	40	32	33	40	41	34	42	36	37	44	45	38	45			
3	4-12.5	30	31	38	45	39	32	40	33	34	41	12	35	43	36	37	44	45	38	46	36	37	44	45	38	45			

**C204/C304 Dimensions**

**C204H  
C304H**

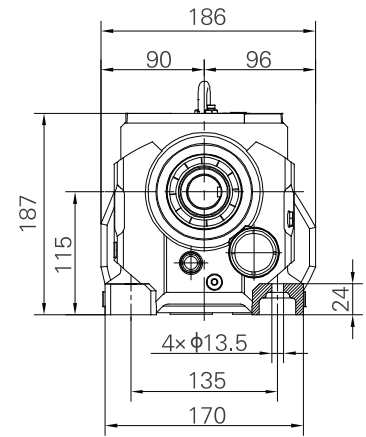
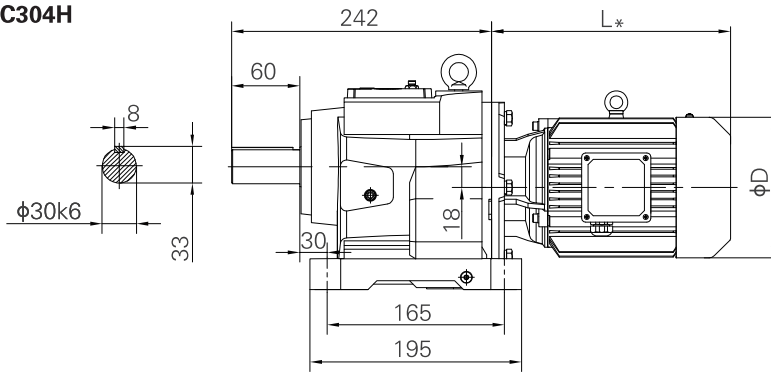

Horizontal foot-mounted

Weight: 14kg ( Without motor and oil )

**C204F  
C304F**

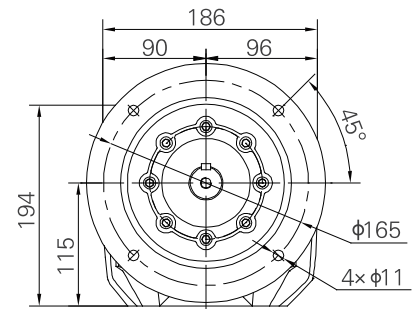
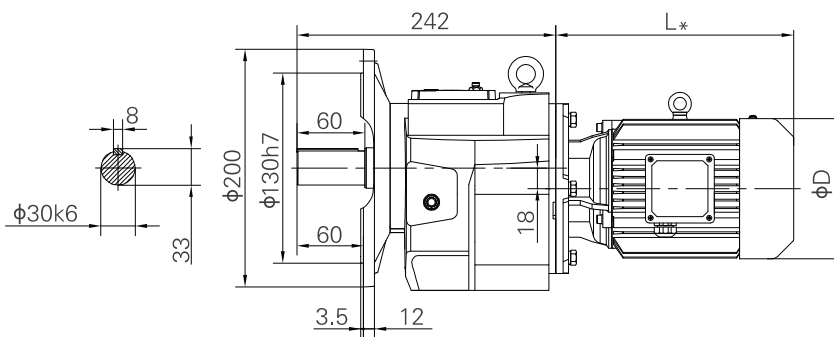

Flange-mounted

Weight: 15kg ( Without motor and oil )

**C204S  
C304S**

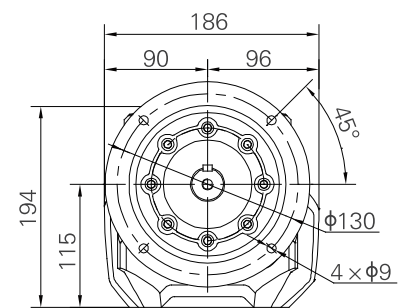
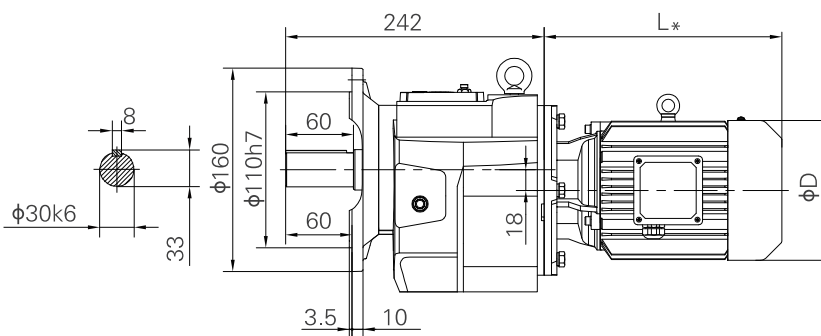

Short flange-mounted

Weight: 14 kg ( Without motor and oil )

### Corresponding motor dimension table for C204/C304

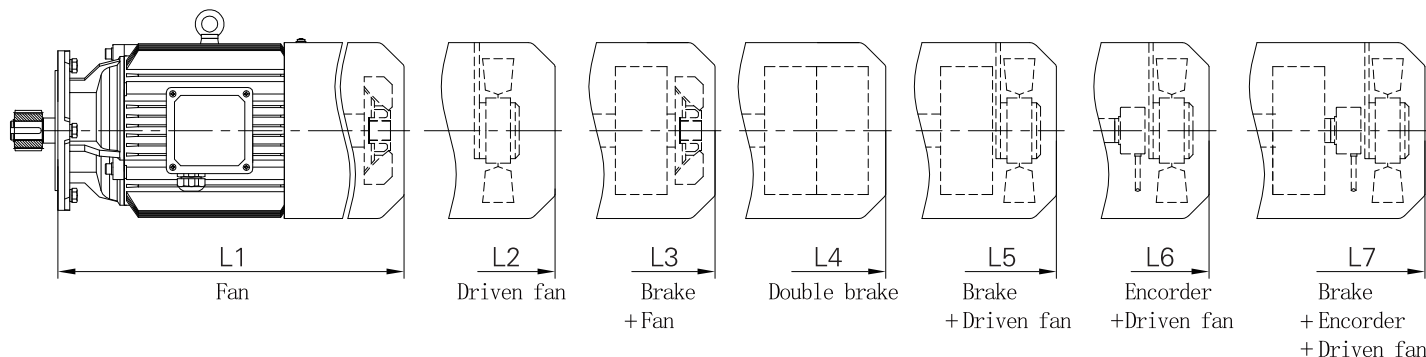

Directly connected motor dimension table

4-pole power (kW)	Range of Ratio	MS							MH							MP							MA							D
		L1	L2	L3	L4	L5	L6	L7	L1	L2	L3	L5	L6	L7	L1	L2	L3	L5	L6	L7	L1	L2	L3	L5	L6	L7				
0.12	4-125	/	262	242	/	297	/	/	207	262	242	297	/	/	207	262	242	297	/	/	207	262	242	297	/	/	124			
0.18	4-125	/	262	242	/	297	/	/	207	262	242	297	/	/	207	262	242	297	/	/	207	262	242	297	/	/	124			
0.25	4-125	/	269	264	/	314	314	354	224	269	264	314	314	354	224	269	264	314	314	354	224	274	264	319	319	359	139			
0.37	4-125	/	269	264	/	314	314	354	224	269	264	314	314	354	224	269	264	314	314	354	224	274	264	319	319	359	139			
0.55	4-100	300	345	360	420	405	405	455	300	345	360	405	405	455	300	345	360	405	405	455	300	345	360	405	405	450	162			
0.75	4-71	300	345	360	420	405	405	455	300	345	360	405	405	455	300	345	360	405	405	455	300	345	360	405	405	450	162			
1.1	4-50	323	368	378	438	423	423	478	323	368	378	423	423	478	323	368	378	423	423	478	348	393	403	453	453	498	176			
1.5	4-35.5	323	368	378	438	423	423	478	323	368	378	423	423	478	348	393	403	448	448	503	348	393	403	453	453	498	176			
2.2	4-25	395	435	470	530	510	510	565	395	435	470	510	510	565	395	435	470	510	510	565	395	450	470	530	530	575	202			
3	4-18	395	435	470	530	510	510	565	395	435	470	510	510	565	395	435	470	510	510	565	395	450	470	530	530	575	202			
4	4-11.2	391	441	466	526	516	516	571	459	509	534	584	584	639	459	509	534	584	584	639	459	519	534	599	599	639	220			

Directly connected motor weight table / kg

4-pole power (kW)	Range of Ratio	MS							MH							MP							MA						
		M1	M2	M3	M4	M5	M6	M7	M1	M2	M3	M5	M6	M7	M1	M2	M3	M5	M6	M7	M1	M2	M3	M5	M6	M7			
0.12	4-125	/	8	9	/	9	/	/	7	8	9	9	/	/	7	8	9	9	/	/	7	7.5	8.5	9	/	/			
0.18	4-125	/	8	9	/	9	/	/	7	8	9	9	/	/	8	9	10	10	/	/	8	8.5	9.5	10	/	/			
0.25	4-125	/	9	10	/	11	10	12	8	9	10	11	10	12	9	10	11	12	11	13	9	10	10.5	11.5	10.5	12.5			
0.37	4-125	/	10	11	/	12	11	13	9	10	11	12	11	13	10	11	12	13	12	14	10	11	11.5	12.5	11.5	13.5			
0.55	4-100	13	14	17	21	18	15	19	14	15	18	19	16	20	15	16	19	20	17	21	15	16	19	20	16.5	21			
0.75	4-71	14	15	18	22	19	16	20	15	16	19	20	17	21	16	17	20	21	18	22	16	17	20	21	17.5	22			
1.1	4-50	16	17	20	24	21	18	22	18	19	22	23	20	24	21	22	25	26	23	27	21	22	25	26	22.5	27			
1.5	4-35.5	17	18	21	25	22	19	23	19	20	23	24	21	25	23	24	27	28	25	29	23	24	27	28	24.5	29			
2.2	4-25	27	28	35	42	36	29	37	30	31	38	39	32	40	32	33	40	41	34	42	36	37	44	45	38	45			
3	4-18	30	31	38	45	39	32	40	33	34	41	42	35	43	36	37	44	45	38	46	36	37	44	45	38	45			
4	4-11.2	45	46	53	61	54	47	55	52	53	60	61	54	62	56	57	64	65	58	66	56	57	64	65	58	66			



**C205/C305 Dimensions**

**C205H  
C305H**

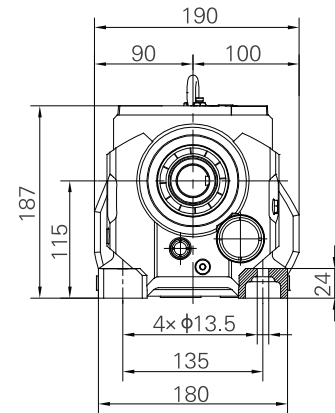
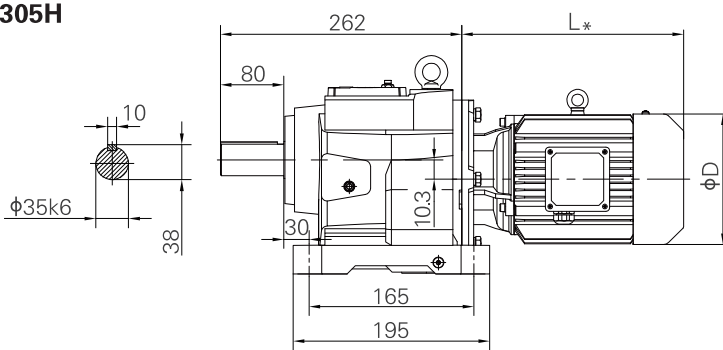

Horizontal foot-mounted

Weight: 18kg ( Without motor and oil )

**C205F  
C305F**

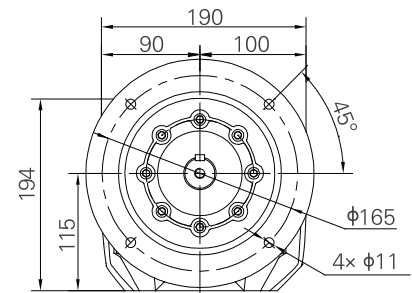
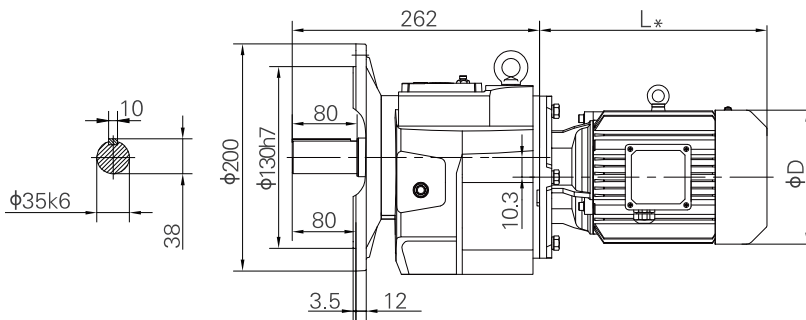

Flange-mounted

Weight: 20kg ( Without motor and oil )

**C205S  
C305S**

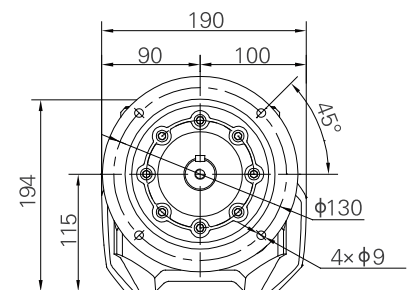
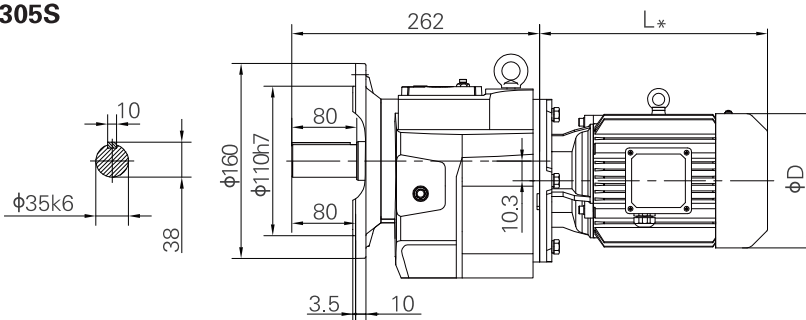

Short flange-mounted

Weight: 19kg ( Without motor and oil )

### Corresponding motor dimension table for C205/C305

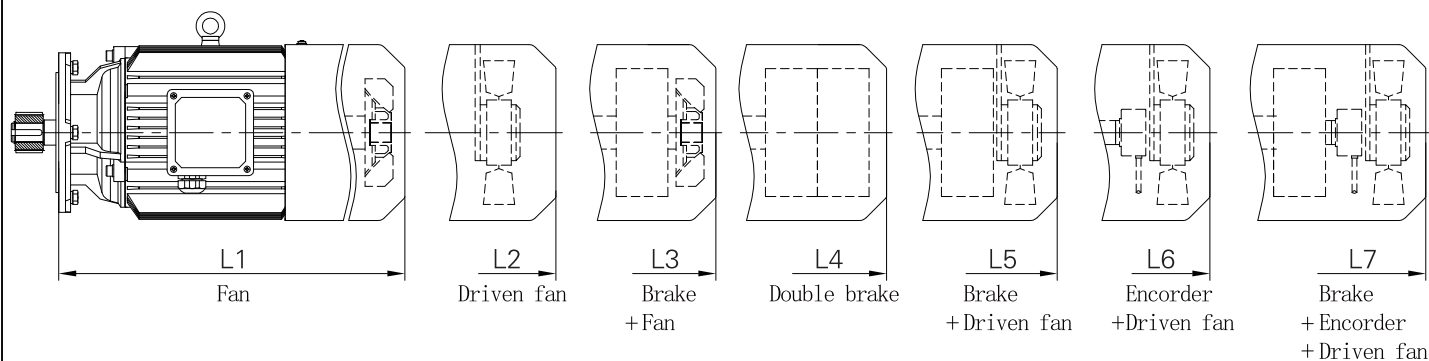

Directly connected motor dimension table

4-pole power (kW)	Range of Ratio	MS							MH							MP							MA							D
		L1	L2	L3	L4	L5	L6	L7	L1	L2	L3	L5	L6	L7	L1	L2	L3	L5	L6	L7	L1	L2	L3	L5	L6	L7				
0.18	4.5-140	/	262	242	/	297	/	/	207	262	242	297	/	/	207	262	242	297	/	/	207	262	242	297	/	/	124			
0.25	4.5-140	/	269	264	/	314	314	354	224	269	264	314	314	354	224	269	264	314	314	354	224	274	264	319	319	359	139			
0.37	4.5-140	/	269	264	/	314	314	354	224	269	264	314	314	354	224	269	264	314	314	354	224	274	264	319	319	359	139			
0.55	4.5-140	300	345	360	420	405	405	455	300	345	360	405	405	455	300	345	360	405	405	455	300	345	360	405	405	450	162			
0.75	4.5-112	300	345	360	420	405	405	455	300	345	360	405	405	455	300	345	360	405	405	455	300	345	360	405	405	450	162			
1.1	4.5-80	323	368	378	438	423	423	478	323	368	378	423	423	478	323	368	378	423	423	478	348	393	403	453	453	498	176			
1.5	4.5-56	323	368	378	438	423	423	478	323	368	378	423	423	478	348	393	403	448	448	503	348	393	403	453	453	498	176			
2.2	4.5-40	395	435	470	530	510	510	565	395	435	470	510	510	565	395	435	470	510	510	565	395	450	470	530	530	575	202			
3	4.5-28	395	435	470	530	510	510	565	395	435	470	510	510	565	395	435	470	510	510	565	395	450	470	530	530	575	202			
4	4.5-22.4	391	441	466	526	516	516	571	459	509	534	584	584	639	459	509	534	584	584	639	459	519	534	599	599	639	220			

Directly connected motor weight table / kg

4-pole power (kW)	Range of Ratio	MS							MH							MP							MA						
		M1	M2	M3	M4	M5	M6	M7	M1	M2	M3	M5	M6	M7	M1	M2	M3	M5	M6	M7	M1	M2	M3	M5	M6	M7			
0.18	4.5-140	/	8	9	/	9	/	/	7	8	9	9	/	/	8	9	10	10	/	/	8	8.5	9.5	10	/	/			
0.25	4.5-140	/	9	10	/	11	10	12	8	9	10	11	10	12	9	10	11	12	11	13	9	10	10.5	11.5	10.5	12.5			
0.37	4.5-140	/	10	11	/	12	11	13	9	10	11	12	11	13	10	11	12	13	12	14	10	11	11.5	12.5	11.5	13.5			
0.55	4.5-140	13	14	17	21	18	15	19	14	15	18	19	16	20	15	16	19	20	17	21	15	16	19	20	16.5	21			
0.75	4.5-112	14	15	18	22	19	16	20	15	16	19	20	17	21	16	17	20	21	18	22	16	17	20	21	17.5	22			
1.1	4.5-80	16	17	20	24	21	18	22	18	19	22	23	20	24	21	22	25	26	23	27	21	22	25	26	22.5	27			
1.5	4.5-56	17	18	21	25	22	19	23	19	20	23	24	21	25	23	24	27	28	25	29	23	24	27	28	24.5	29			
2.2	4.5-40	27	28	35	42	36	29	37	30	31	38	39	32	40	32	33	40	41	34	42	36	37	44	45	38	45			
3	4.5-28	30	31	38	45	39	32	40	33	34	41	42	35	43	36	37	44	45	38	46	36	37	44	45	38	45			
4	4.5-22.4	45	46	53	61	54	47	55	52	53	60	61	54	62	56	57	64	65	58	66	56	57	64	65	58	66			

**C206/C306 Dimensions**

**C206H  
C306H**

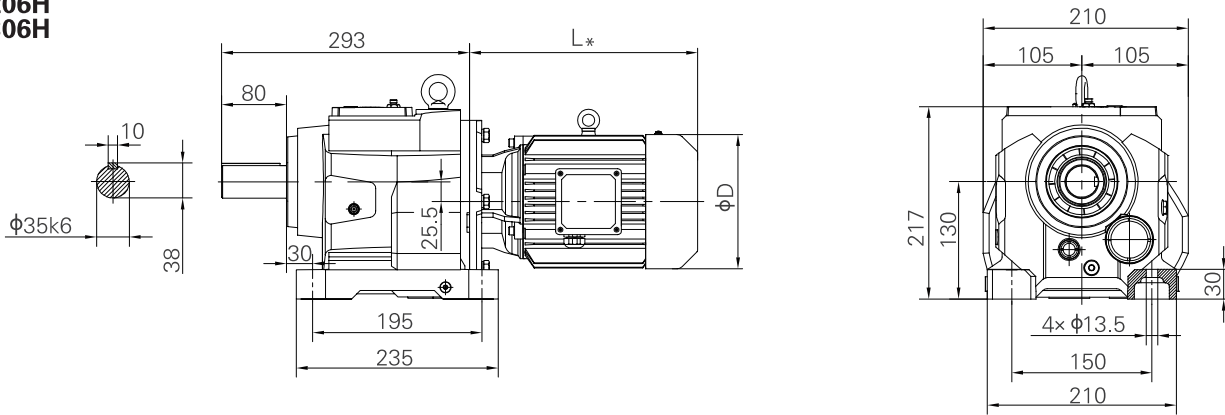

Horizontal foot-mounted

Weight: 25kg ( Without motor and oil )

**C206F  
C306F**

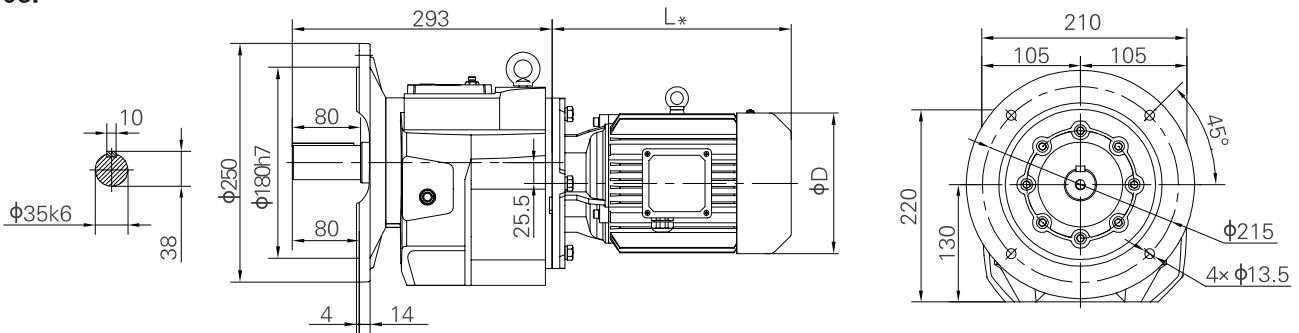

Flange-mounted

Weight: 27kg ( Without motor and oil )

**C206S  
C306S**

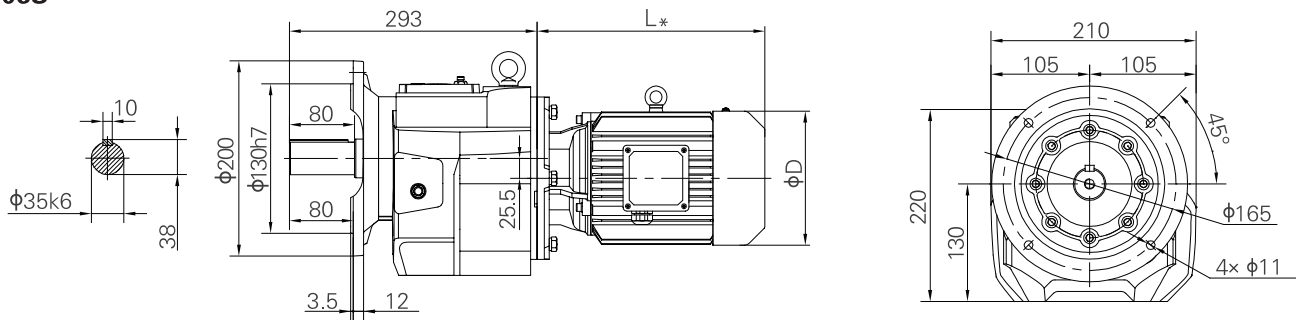

Short flange-mounted

Weight: 36kg ( Without motor and oil )

**Corresponding motor dimension table for C206/C306**

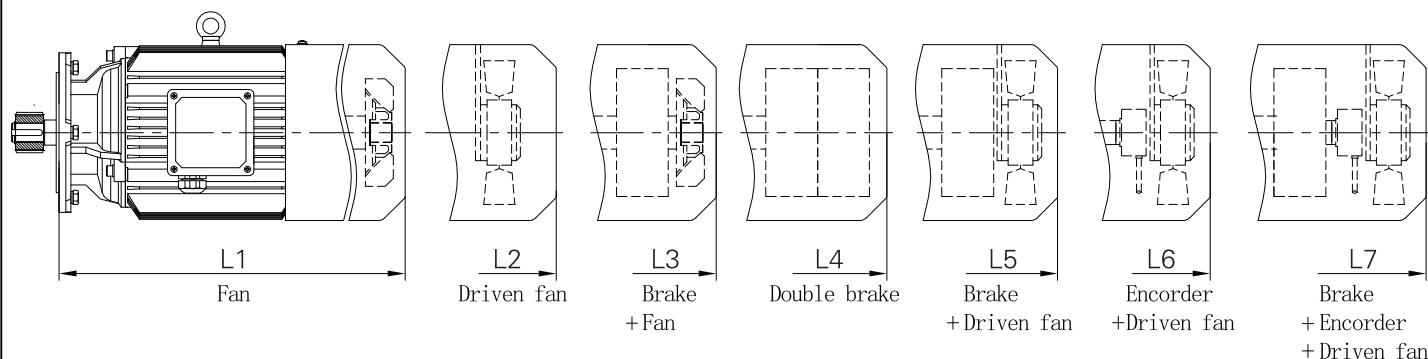

Directly connected motor dimension table

4-pole power (kW)	Range of Ratio	MS							MH							MP							MA							D
		L1	L2	L3	L4	L5	L6	L7	L1	L2	L3	L5	L6	L7	L1	L2	L3	L5	L6	L7	L1	L2	L3	L5	L6	L7				
0.25	112-160	/	269	264	/	314	314	354	224	269	264	314	314	354	224	269	264	314	314	354	224	274	264	319	319	359	139			
0.37	71-160	/	269	264	/	314	314	354	224	269	264	314	314	354	224	269	264	314	314	354	224	274	264	319	319	359	139			
0.55	50-160	300	345	360	420	405	405	455	300	345	360	405	405	455	300	345	360	405	405	455	300	345	360	405	405	450	162			
0.75	35.5-160	300	345	360	420	405	405	455	300	345	360	405	405	455	300	345	360	405	405	455	300	345	360	405	405	450	162			
1.1	20-100	323	368	378	438	423	423	478	323	368	378	423	423	478	323	368	378	423	423	478	348	393	403	453	453	498	176			
1.5	14-80	323	368	378	438	423	423	478	323	368	378	423	423	478	348	393	403	448	448	503	348	393	403	453	453	498	176			
2.2	9-56	395	435	470	530	510	510	565	395	435	470	510	510	565	395	435	470	510	510	565	395	450	470	530	530	575	202			
3	5.6-40	395	435	470	530	510	510	565	395	435	470	510	510	565	395	435	470	510	510	565	395	450	470	530	530	575	202			
4	4.5-28	391	441	466	526	516	516	571	459	509	534	584	584	639	459	509	534	584	584	639	459	519	534	599	599	639	220			
5.5	4.5-11.2	432	482	512	577	557	557	612	432	482	512	557	557	612	470	520	550	595	595	650	508	573	588	658	658	688	259			
7.5	4.5-11.2	470	520	550	615	595	595	650	470	520	550	595	595	650	508	558	588	633	633	688	508	573	588	658	658	688	259			

Directly connected motor weight table / kg

4-pole power (kW)	Range of Ratio	MS							MH							MP							MA							
		M1	M2	M3	M4	M5	M6	M7	M1	M2	M3	M5	M6	M7	M1	M2	M3	M5	M6	M7	M1	M2	M3	M5	M6	M7				
0.25	112-160	/	9	10	/	11	10	12	8	9	10	11	10	12	9	10	11	12	11	13	9	10	10.5	11.5	10.5	12.5				
0.37	71-160	/	10	11	/	12	11	13	9	10	11	12	11	13	10	11	12	13	12	14	10	11	11.5	12.5	11.5	13.5				
0.55	50-160	13	14	17	21	18	15	19	14	15	18	19	16	20	15	16	19	20	17	21	15	16	19	20	16.5	21				
0.75	35.5-160	14	15	18	22	19	16	20	15	16	19	20	17	21	16	17	20	21	18	22	16	17	20	21	17.5	22				
1.1	20-100	16	17	20	24	21	18	22	18	19	22	23	20	24	21	22	25	26	23	27	21	22	25	26	22.5	27				
1.5	14-80	17	18	21	25	22	19	23	19	20	23	24	21	25	23	24	27	28	25	29	23	24	27	28	24.5	29				
2.2	9-56	27	28	35	42	36	29	37	30	31	38	39	32	40	32	33	40	41	34	42	36	37	44	45	38	45				
3	5.6-40	30	31	38	45	39	32	40	33	34	41	42	35	43	36	37	44	45	38	46	36	37	44	45	38	45				
4	4.5-28	45	46	53	61	54	47	55	52	53	60	61	54	62	56	57	64	65	58	66	56	57	64	65	58	66				
5.5	4.5-11.2	63	65	74	85	76	66	77	67	69	78	80	70	81	77	79	88	90	80	91	77	79	88	90	80	91				
7.5	4.5-11.2	73	75	84	95	86	76	87	80	82	91	93	83	94	88	90	99	101	91	102	88	90	99	101	91	102				

**C207/C307 Dimensions**

**C207H  
C307H**

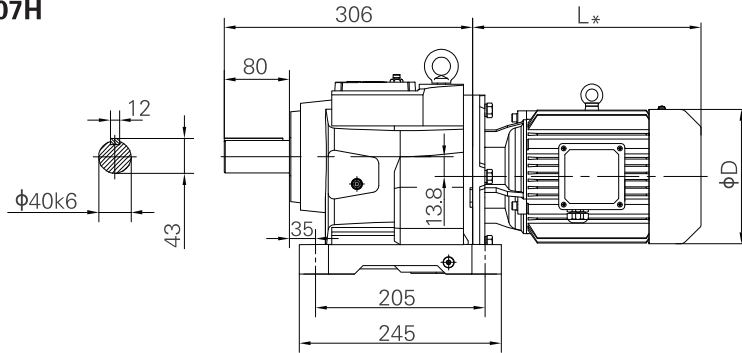

Horizontal foot-mounted

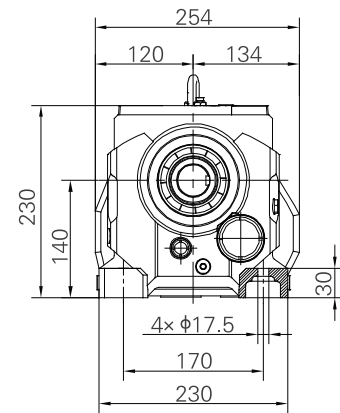

Weight: 33kg ( Without motor and oil )

**C207F  
C307F**

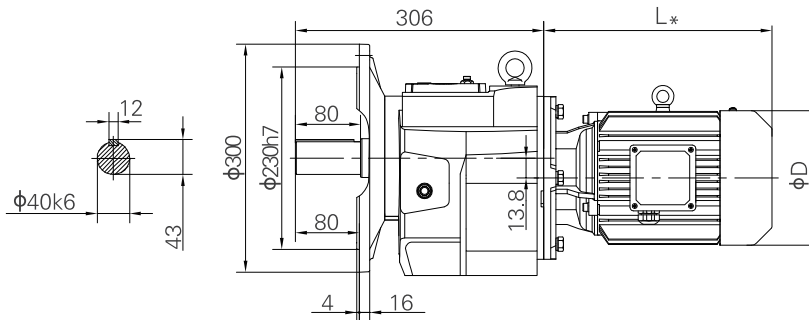

Flange-mounted

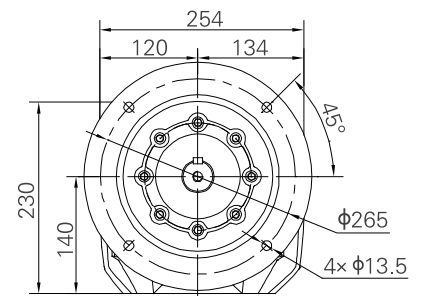

Weight: 36kg ( Without motor and oil )

**C207S  
C307S**

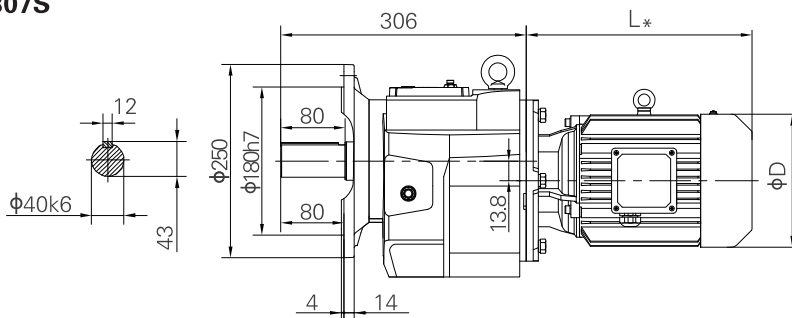

Short flange-mounted

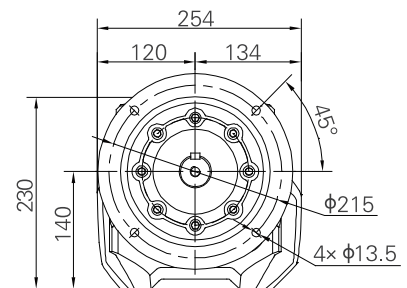

Weight: 34kg ( Without motor and oil )

**Corresponding motor dimension table for C207/C307**

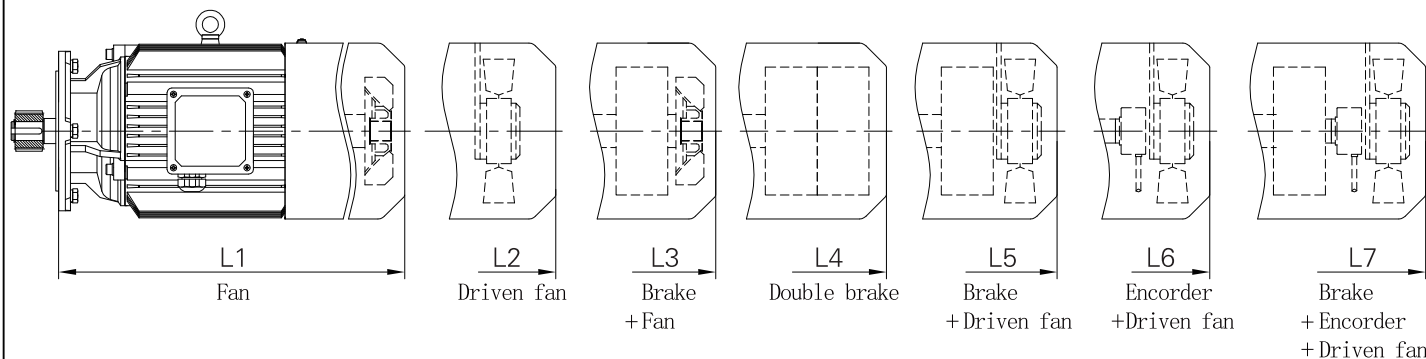

Directly connected motor dimension table

4-pole power (kW)	Range of Ratio	MS							MH							MP							MA							D
		L1	L2	L3	L4	L5	L6	L7	L1	L2	L3	L4	L5	L6	L7	L1	L2	L3	L5	L6	L7	L1	L2	L3	L5	L6	L7			
0.25	140-180	/	261	256	/	306	306	346	216	261	256	/	306	306	346	216	261	256	306	306	346	216	266	256	311	311	351	139		
0.37	90-180	/	261	256	/	306	306	346	216	261	256	/	306	306	346	216	261	256	306	306	346	216	266	256	311	311	351	139		
0.55	71-180	292	337	352	412	397	397	447	292	337	352	/	397	397	447	292	337	352	397	397	447	292	337	352	397	397	442	162		
0.75	50-180	292	337	352	412	397	397	447	292	337	352	/	397	397	447	292	337	352	397	397	447	292	337	352	397	397	442	162		
1.1	31.5-100	315	360	370	430	415	415	470	315	360	370	/	415	415	470	315	360	370	415	415	470	340	385	395	445	445	490	176		
1.5	22.4-100	315	360	370	430	415	415	470	315	360	370	/	415	415	470	340	385	395	440	440	495	340	385	395	445	445	490	176		
2.2	14-80	387	427	462	522	502	502	557	387	427	462	/	502	502	557	387	427	462	502	502	557	387	442	462	522	522	567	202		
3	9-56	387	427	462	522	502	502	557	387	427	462	/	502	502	557	387	427	462	502	502	557	387	442	462	522	522	567	202		
4	7.1-40	383	433	458	518	508	508	563	451	501	526	/	576	576	631	451	501	526	576	576	631	451	511	526	591	591	631	220		
5.5	5-28	421	471	501	566	546	546	601	421	471	501	/	546	546	601	459	509	539	584	584	639	497	562	577	647	647	677	259		
7.5	4-18	459	509	539	604	584	584	639	459	509	539	/	584	584	639	497	547	577	622	622	677	497	562	577	647	647	677	259		
11	4-12.5	/	542	602	/	632	632	682	507	542	602	652	632	632	682	551	586	646	676	676	726	551	601	646	701	701	736	314		
15	4-8	/	586	646	/	676	676	726	551	586	646	696	676	676	726	581	616	676	706	706	756	581	631	676	731	731	766	314		

Directly connected motor weight table / kg

4-pole power (kW)	Range of Ratio	MS							MH							MP							MA							
		M1	M2	M3	M4	M5	M6	M7	M1	M2	M3	M4	M5	M6	M7	M1	M2	M3	M5	M6	M7	M1	M2	M3	M5	M6	M7			
0.25	140-180	/	9	10	/	11	10	12	8	9	10	/	11	10	12	9	10	11	12	11	13	9	10	10.5	11.5	10.5	12.5			
0.37	90-180	/	10	11	/	12	11	13	9	10	11	/	12	11	13	10	11	12	13	12	14	10	11	11.5	12.5	11.5	13.5			
0.55	71-180	13	14	17	21	18	15	19	14	15	18	/	19	16	20	15	16	19	20	17	21	15	16	19	20	16.5	21			
0.75	50-180	14	15	18	22	19	16	20	15	16	19	/	20	17	21	16	17	20	21	18	22	16	17	20	21	17.5	22			
1.1	31.5-100	16	17	20	24	21	18	22	18	19	22	/	23	20	24	21	22	25	26	23	27	21	22	25	26	22.5	27			
1.5	22.4-100	17	18	21	25	22	19	23	19	20	23	/	24	21	25	23	24	27	28	25	29	23	24	27	28	24.5	29			
2.2	14-80	27	28	35	42	36	29	37	30	31	38	/	39	32	40	32	33	40	41	34	42	36	37	44	45	38	45			
3	9-56	30	31	38	45	39	32	40	33	34	41	/	42	35	43	36	37	44	45	38	46	36	37	44	45	38	45			
4	7.1-40	45	46	53	61	54	47	55	52	53	60	/	61	54	62	56	57	64	65	58	66	56	57	64	65	58	66			
5.5	5-28	63	65	74	85	76	66	77	67	69	78	/	80	70	81	77	79	88	90	80	91	77	79	88	90	80	91			
7.5	4-18	73	75	84	95	86	76	87	80	82	91	/	93	83	94	88	90	99	101	91	102	88	90	99	101	91	102			
11	4-12.5	/	123	142	/	143	124	144	121	123	142	162	143	124	144	129	131	150	151	132	152	129	131	150	151	132	152			
15	4-8	/	141	160	/	161	142	162	139	141	160	180	161	142	162	161	163	182	183	164	184	161	163	182	183	164	184			

**C208/C308 Dimensions**

**C208H  
C308H**

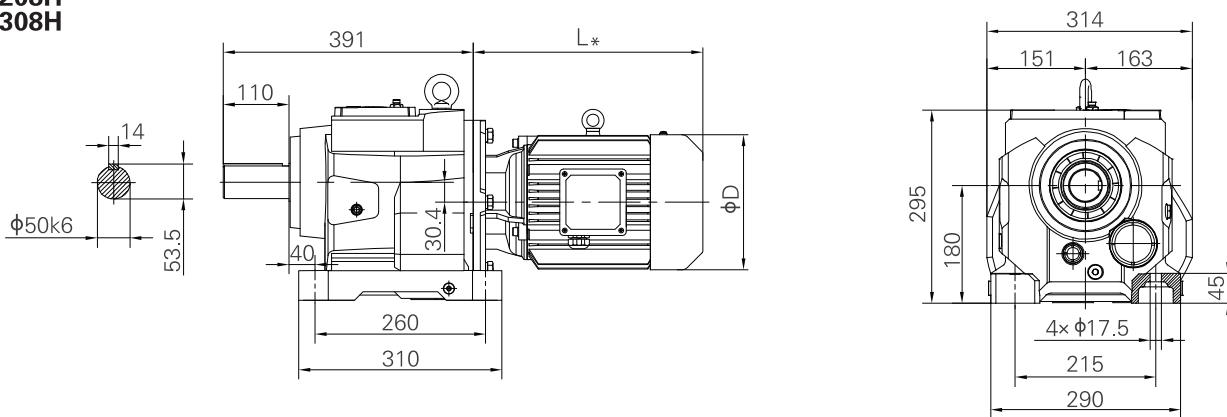

Horizontal foot-mounted

Weight: 60kg ( Without motor and oil )

**C208F  
C308F**

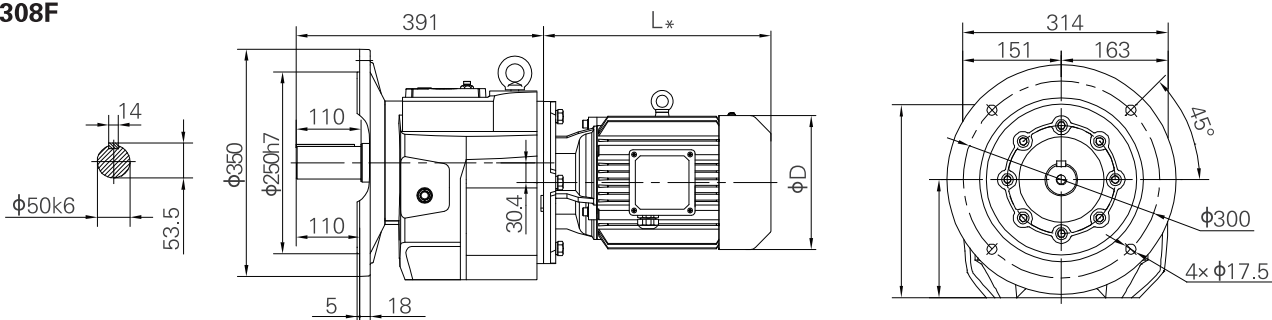

Flange-mounted

Weight: 66kg ( Without motor and oil )

**C208S  
C308S**

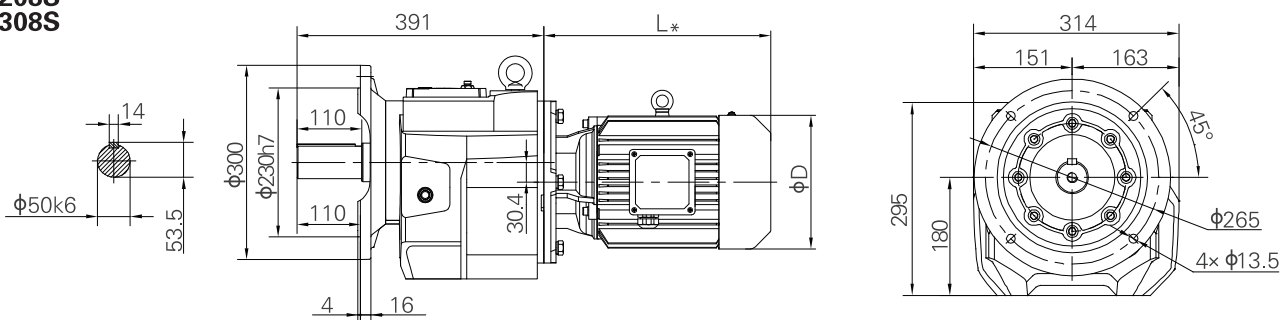

Short flange-mounted

Weight: 64kg ( Without motor and oil )

### Corresponding motor dimension table for C208/C308

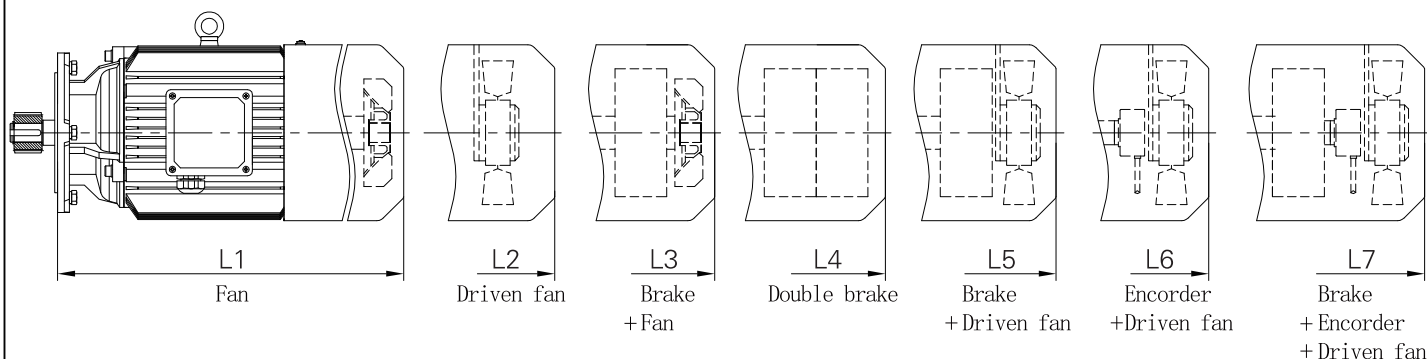

#### Directly connected motor dimension table

4-pole power (kW)	Range of Ratio	MS							MH							MP							MA							D
		L1	L2	L3	L4	L5	L6	L7	L1	L2	L3	L4	L5	L6	L7	L1	L2	L3	L5	L6	L7	L1	L2	L3	L5	L6	L7			
0.55	140-200	283	328	343	403	388	388	438	283	328	343	/	388	388	438	283	328	343	388	388	438	283	328	343	388	388	433	162		
0.75	100-200	283	328	343	403	388	388	438	283	328	343	/	388	388	438	283	328	343	388	388	438	283	328	343	388	388	433	162		
1.1	63-160	306	351	361	421	406	406	461	306	351	361	/	406	406	461	306	351	361	406	406	461	331	376	386	436	436	481	176		
1.5	50-160	306	351	361	421	406	406	461	306	351	361	/	406	406	461	331	376	386	431	431	486	331	376	386	436	436	481	176		
2.2	31.5-160	378	418	453	513	493	493	548	378	418	453	/	493	493	548	378	418	453	493	493	548	378	433	453	513	513	558	202		
3	20-112	378	418	453	513	493	493	548	378	418	453	/	493	493	548	378	418	453	493	493	548	378	433	453	513	513	558	202		
4	12.5-80	374	424	449	509	499	499	554	442	492	517	/	567	567	622	442	492	517	567	567	622	442	502	517	582	582	622	220		
5.5	9-56	413	463	493	558	538	538	593	413	463	493	/	538	538	593	451	501	531	576	576	631	489	554	569	639	639	669	259		
7.5	7.1-45	451	501	531	596	576	576	631	451	501	531	/	576	576	631	489	539	569	614	614	669	489	554	569	639	639	669	259		
11	4.5-28	/	541	601	/	631	631	681	506	541	601	651	631	631	681	550	585	645	675	675	725	550	600	645	700	700	735	314		
15	4.5-18	/	585	645	/	675	675	725	550	585	645	695	675	675	725	580	615	675	705	705	755	580	630	675	730	730	765	314		
18.5	4.5-12.5	/	651	731	/	756	756	796	621	651	731	786	731	756	801	621	651	731	756	756	801	621	666	731	776	776	816	356		
22	4.5-10	/	699	779	/	804	804	849	669	699	779	834	779	804	849	669	699	779	804	804	849	669	714	779	824	824	864	356		

#### Directly connected motor weight table / kg

4-pole power (kW)	Range of Ratio	MS							MH							MP							MA						
		M1	M2	M3	M4	M5	M6	M7	M1	M2	M3	M4	M5	M6	M7	M1	M2	M3	M5	M6	M7	M1	M2	M3	M5	M6	M7		
0.55	140-200	13	14	17	21	18	15	19	14	15	18	/	19	16	20	15	16	19	20	17	21	15	16	19	20	16.5	21		
0.75	100-200	14	15	18	22	19	16	20	15	16	19	/	20	17	21	16	17	20	21	18	22	16	17	20	21	17.5	22		
1.1	63-160	16	17	20	24	21	18	22	18	19	22	/	23	20	24	21	22	25	26	23	27	21	22	25	26	22.5	27		
1.5	50-160	17	18	21	25	22	19	23	19	20	23	/	24	21	25	23	24	27	28	25	29	23	24	27	28	24.5	29		
2.2	31.5-160	27	28	35	42	36	29	37	30	31	38	/	39	32	40	32	33	40	41	34	42	36	37	44	45	38	45		
3	20-112	30	31	38	45	39	32	40	33	34	41	/	42	35	43	36	37	44	45	38	46	36	37	44	45	38	45		
4	12.5-80	45	46	53	61	54	47	55	52	53	60	/	61	54	62	56	57	64	65	58	66	56	57	64	65	58	66		
5.5	9-56	63	65	74	85	76	66	77	67	69	78	/	80	70	81	77	79	88	90	80	91	77	79	88	90	80	91		
7.5	7.1-45	73	75	84	95	86	76	87	80	82	91	/	93	83	94	88	90	99	101	91	102	88	90	99	101	91	102		
11	4.5-28	/	123	142	/	143	124	144	121	123	142	162	143	124	144	129	131	150	151	132	152	129	131	150	151	132	152		
15	4.5-18	/	141	160	/	161	142	162	139	141	160	180	161	142	162	161	163	182	183	164	184	161	163	182	183	164	184		
18.5	4.5-12.5	/	184	214	/	215	185	217	182	184	214	246	215	185	217	200	202	232	233	203	235	200	202	232	233	203	235		
22	4.5-10	/	206	236	/	237	207	239	204	206	236	268	237	207	239	220	222	252	253	223	255	220	222	252	253	223	255		



**C209/C309 Dimensions**

**C209H  
C309H**

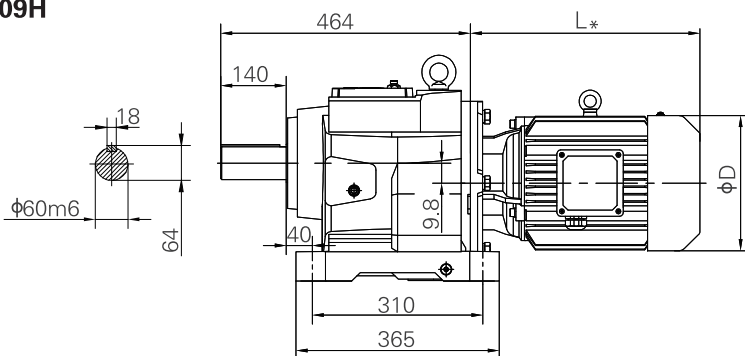

Horizontal foot-mounted

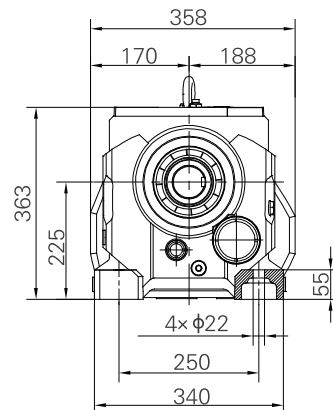

Weight: 110kg ( Without motor and oil )

**C209F  
C309F**

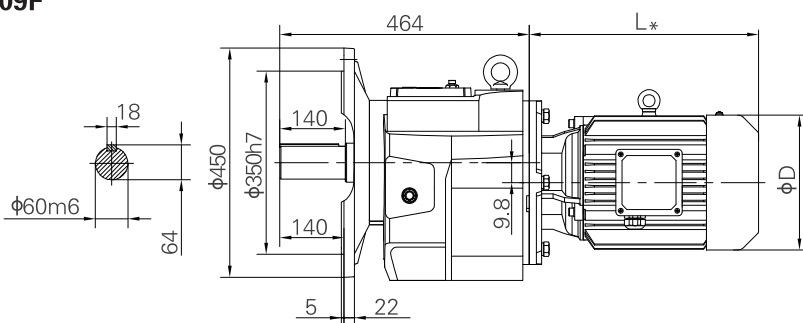

Flange-mounted

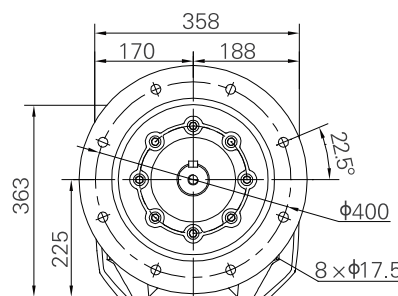

Weight: 120kg ( Without motor and oil )

**C209S  
C309S**

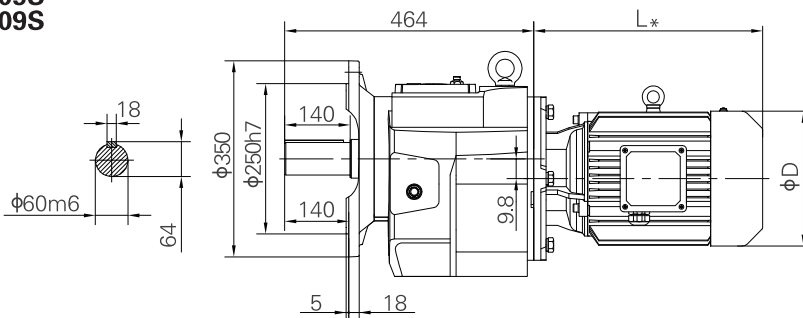

Short flange-mounted

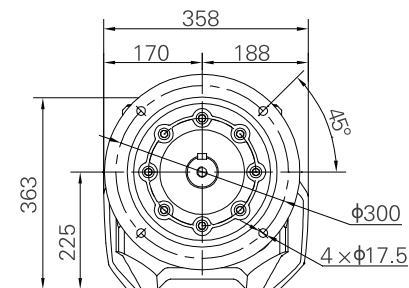

Weight: 115kg ( Without motor and oil )

**Corresponding motor dimension table for C209/C309**

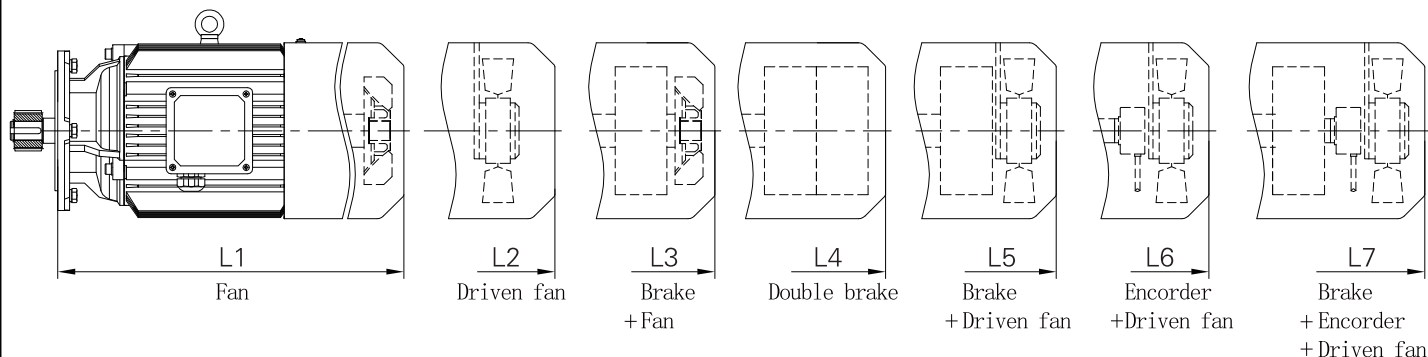

Directly connected motor dimension table

4-pole power (kW)	Range of Ratio	MS							MH							MP							MA							D
		L1	L2	L3	L4	L5	L6	L7	L1	L2	L3	L4	L5	L6	L7	L1	L2	L3	L5	L6	L7	L1	L2	L3	L5	L6	L7			
0.55	250-280	280	325	340	400	385	385	435	280	325	340	/	385	385	435	280	325	340	385	385	435	280	325	340	385	385	430	162		
0.75	180-280	280	325	340	400	385	385	435	280	325	340	/	385	385	435	280	325	340	385	385	435	280	325	340	385	385	430	162		
1.1	125-224	303	348	358	418	403	403	458	303	348	358	/	403	403	458	303	348	358	403	403	458	328	373	383	433	433	478	176		
1.5	90-224	303	348	358	418	403	403	458	303	348	358	/	403	403	458	328	373	383	428	428	483	328	373	383	433	433	478	176		
2.2	63-224	374	414	449	509	489	489	544	374	414	449	/	489	489	544	374	414	449	489	489	544	374	429	449	509	509	554	202		
3	45-200	374	414	449	509	489	489	544	374	414	449	/	489	489	544	374	414	449	489	489	544	374	429	449	509	509	554	202		
4	31.5-140	370	420	445	505	495	495	550	438	488	513	/	563	563	618	438	488	513	563	563	618	438	498	513	578	578	618	220		
5.5	20-112	412	462	492	557	537	537	592	412	462	492	/	537	537	592	450	500	530	575	575	630	488	553	568	638	638	668	259		
7.5	12.5-80	450	500	530	595	575	575	630	450	500	530	/	575	575	630	488	538	568	613	613	668	488	553	568	638	638	668	259		
11	8-56	/	535	595	/	625	625	675	500	535	595	645	625	625	675	544	579	639	669	669	719	544	594	639	694	694	729	314		
15	5-40	/	579	639	/	669	669	719	544	579	639	689	669	669	719	574	609	669	699	699	749	574	624	669	724	724	759	314		
18.5	4-31.5	/	645	725	/	750	750	795	615	645	725	780	725	750	795	615	645	725	750	750	795	615	660	725	770	770	810	356		
22	4-25	/	693	773	/	798	798	843	663	693	773	828	773	798	843	663	693	773	798	798	843	663	708	773	818	818	858	356		
30	4-16	/	710	820	/	825	825	870	705	710	820	845	825	825	870	705	710	820	825	825	870	705	725	820	845	845	890	398		

Directly connected motor weight table / kg

4-pole power (kW)	Range of Ratio	MS							MH							MP							MA						
		M1	M2	M3	M4	M5	M6	M7	M1	M2	M3	M4	M5	M6	M7	M1	M2	M3	M5	M6	M7	M1	M2	M3	M5	M6	M7		
0.55	250-280	13	14	17	21	18	15	19	14	15	18	/	19	16	20	15	16	19	20	17	21	15	16	19	20	16.5	21		
0.75	180-280	14	15	18	22	19	16	20	15	16	19	/	20	17	21	16	17	20	21	18	22	16	17	20	21	17.5	22		
1.1	125-224	16	17	20	24	21	18	22	18	19	22	/	23	20	24	20	21	24	25	22	26	21	22	25	26	22.5	27		
1.5	90-224	17	18	21	25	22	19	23	19	20	23	/	24	21	25	22	23	26	27	24	28	23	24	27	28	24.5	29		
2.2	63-224	27	28	35	42	36	29	37	30	31	38	/	39	32	40	32	33	40	41	34	42	36	37	44	45	38	45		
3	45-200	30	31	38	45	39	32	40	33	34	41	/	42	35	43	36	37	44	45	38	46	36	37	44	45	38	45		
4	31.5-140	45	46	53	61	54	47	55	52	53	60	/	61	54	62	56	57	64	65	58	66	56	57	64	65	58	66		
5.5	20-112	63	65	74	85	76	66	77	67	69	78	/	80	70	81	77	79	88	90	80	91	77	79	88	90	80	91		
7.5	12.5-80	73	75	84	95	86	76	87	80	82	91	/	93	83	94	88	90	99	101	91	102	88	90	99	101	91	102		
11	8-56	/	123	142	/	143	124	144	121	123	142	162	143	124	144	129	131	150	151	132	152	129	131	150	151	132	152		
15	5-40	/	141	160	/	161	142	162	139	141	160	180	161	142	162	161	163	182	183	164	184	161	163	182	183	164	184		
18.5	4-31.5	/	184	214	/	215	185	217	182	184	214	246	215	185	217	200	202	232	233	203	235	200	202	232	233	203	235		
22	4-25	/	206	236	/	237	207	239	204	206	236	268	237	207	239	220	222	252	253	223	255	220	222	252	253	223	255		
30	4-16	/	260	310	/	308	261	310	260	260	310	360	308	261	310	280	280	330	328	281	330	280	280	330	328	281	330		

**C210/C310 Dimensions**

**C210H  
C310H**

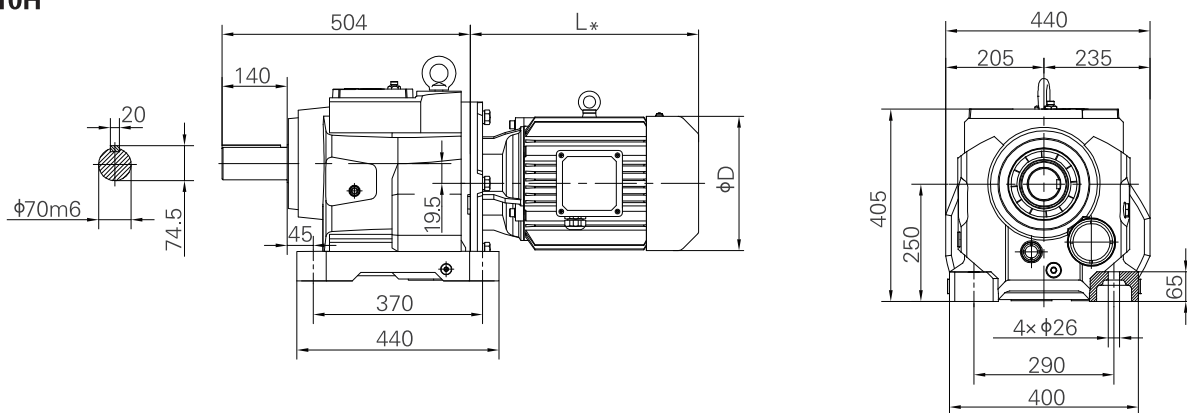

Horizontal foot-mounted

Weight: 150kg ( Without motor and oil )

**C210F  
C310F**

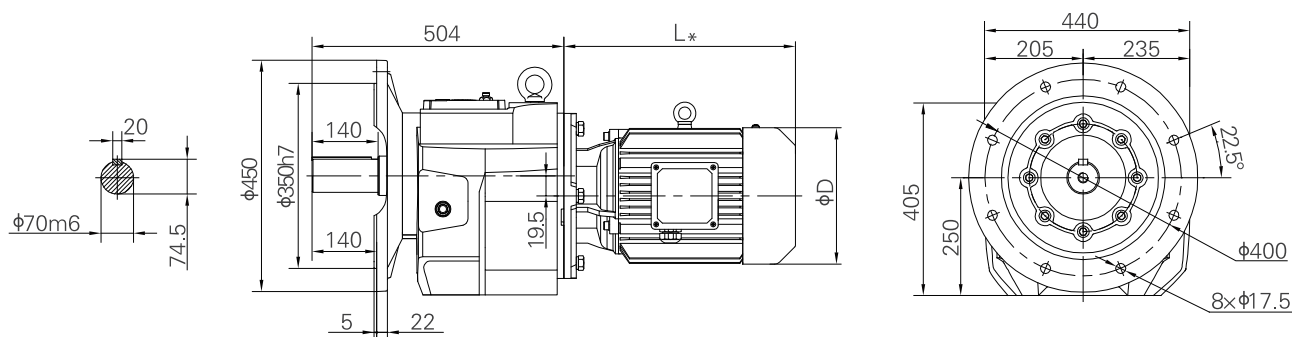

Flange-mounted

Weight: 165kg ( Without motor and oil )

**C210S  
C310S**

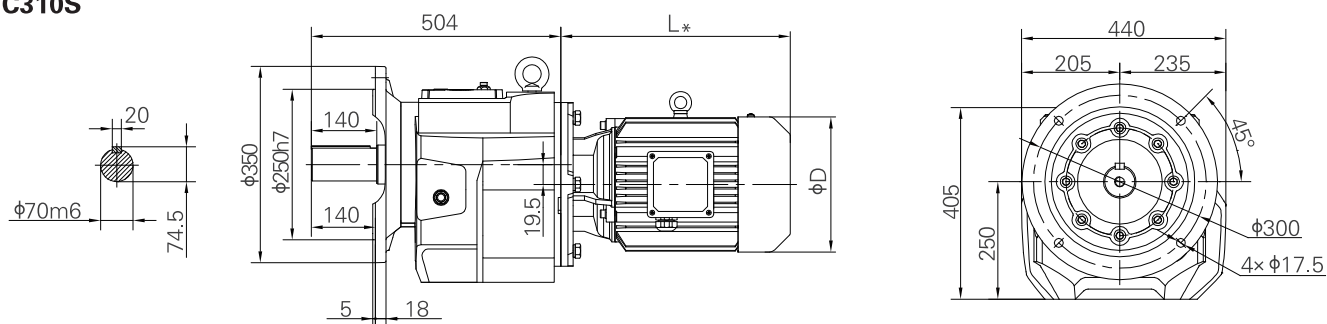

Short flange-mounted

Weight: 158kg ( Without motor and oil )

**Corresponding motor dimension table for C210/C310**

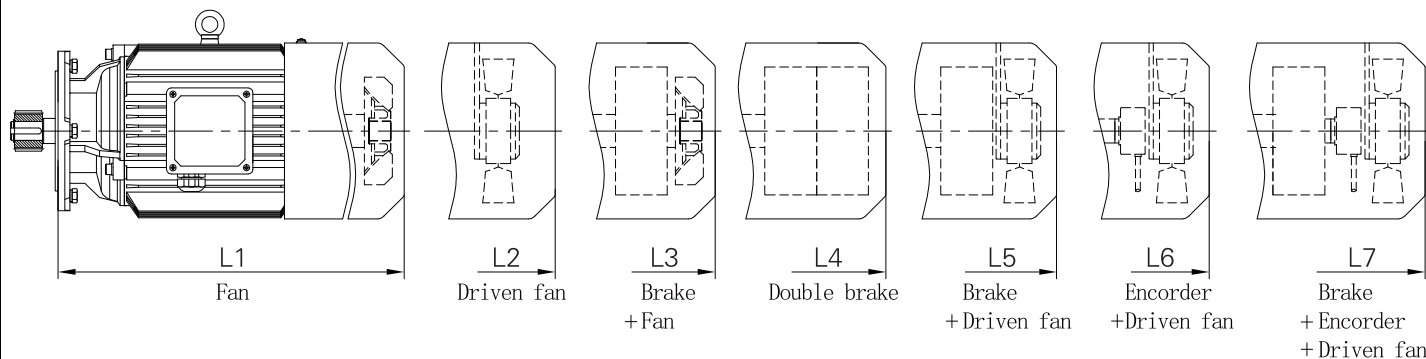

Directly connected motor dimension table

4-pole power (kW)	Range of Ratio	MS							MH							MP							MA							D
		L1	L2	L3	L4	L5	L6	L7	L1	L2	L3	L4	L5	L6	L7	L1	L2	L3	L5	L6	L7	L1	L2	L3	L5	L6	L7			
1.5	112-224	300	345	355	415	400	400	455	300	345	355	/	400	400	455	325	370	380	425	425	480	325	370	380	430	430	475	176		
2.2	80-224	370	410	445	505	485	485	540	370	410	445	/	485	485	540	370	410	445	485	485	540	370	425	445	505	505	550	202		
3	63-224	370	410	445	505	485	485	540	370	410	445	/	485	485	540	370	410	445	485	485	540	370	425	445	505	505	550	202		
4	45-200	366	416	441	501	491	491	546	434	484	509	/	559	559	614	434	484	509	559	559	614	434	494	509	574	574	614	220		
5.5	31.5-140	401	451	481	546	526	526	581	401	451	481	/	526	526	581	439	489	519	564	564	619	477	542	557	627	627	657	259		
7.5	25-100	439	489	519	584	564	564	619	439	489	519	/	564	564	619	477	527	557	602	602	657	477	542	557	627	627	657	259		
11	18-71	/	524	584	/	614	614	664	489	524	584	634	614	614	664	533	568	628	658	658	708	533	583	628	683	683	718	314		
15	12.5-56	/	568	628	/	658	658	708	533	568	628	678	658	658	708	563	598	658	688	688	738	563	613	658	713	713	748	314		
18.5	10-45	/	634	714	/	739	739	784	604	634	714	769	714	739	784	604	634	714	739	739	784	604	649	714	759	759	799	356		
22	7.1-40	/	682	762	/	787	787	832	652	682	762	817	762	787	832	652	682	762	787	787	832	652	697	762	807	807	847	356		
30	4.5-28	/	710	820	/	825	825	870	705	710	820	845	825	825	870	705	710	820	825	825	870	705	725	820	845	845	890	398		
37	4-22.4	/	776	861	/	891	891	936	746	776	861	/	891	891	936	746	776	861	891	891	936	746	781	861	901	901	941	446		
45	4-20	/	776	861	/	891	891	936	746	776	861	/	891	891	936	746	776	861	891	891	936	746	781	861	901	901	941	446		

Directly connected motor weight table / kg

4-pole power (kW)	Range of Ratio	MS							MH							MP							MA						
		M1	M2	M3	M4	M5	M6	M7	M1	M2	M3	M4	M5	M6	M7	M1	M2	M3	M5	M6	M7	M1	M2	M3	M5	M6	M7		
1.5	112-224	17	18	21	25	22	19	23	19	20	23	/	24	21	25	23	24	27	28	25	29	23	24	27	28	24.5	29		
2.2	80-224	27	28	35	42	36	29	37	30	31	38	/	39	32	40	32	33	40	41	34	42	36	37	44	45	38	45		
3	63-224	30	31	38	45	39	32	40	33	34	41	/	42	35	43	36	37	44	45	38	46	36	37	44	45	38	45		
4	45-200	45	46	53	61	54	47	55	52	53	60	/	61	54	62	56	57	64	65	58	66	56	57	64	65	58	66		
5.5	31.5-140	63	65	74	85	76	66	77	67	69	78	/	80	70	81	77	79	88	90	80	91	77	79	88	90	80	91		
7.5	25-100	73	75	84	95	86	76	87	80	82	91	/	93	83	94	88	90	99	101	91	102	88	90	99	101	91	102		
11	18-71	/	123	142	/	143	124	144	121	123	142	162	143	124	144	129	131	150	151	132	152	129	131	150	151	132	152		
15	12.5-56	/	141	160	/	161	142	162	139	141	160	180	161	142	162	161	163	182	183	164	184	161	163	182	183	164	184		
18.5	10-45	/	184	214	/	215	185	217	182	184	214	246	215	185	217	200	202	232	233	203	235	200	202	232	233	203	235		
22	7.1-40	/	206	236	/	237	207	239	204	206	236	268	237	207	239	220	222	252	253	223	255	220	222	252	253	223	255		
30	4.5-28	/	260	310	/	308	261	310	260	260	310	360	308	261	310	280	280	330	328	281	330	280	280	330	328	281	330		
37	4-22.4	/	332	380	/	381	334	383	330	332	380	/	381	334	383	345	347	395	396	349	398	345	347	395	396	349	398		
45	4-20	/	347	395	/	396	349	398	345	347	395	/	396	349	398	365	367	415	416	369	418	365	367	415	416	369	418		

**C212/C312 Dimensions**

**C212H  
C312H**

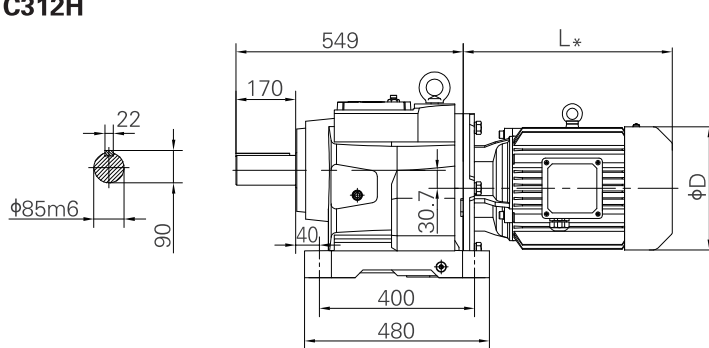

Horizontal foot-mounted

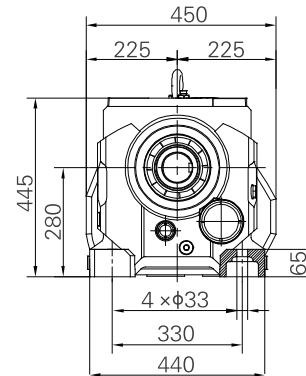

Weight: 175kg ( Without motor and oil )

**C212F  
C312F**

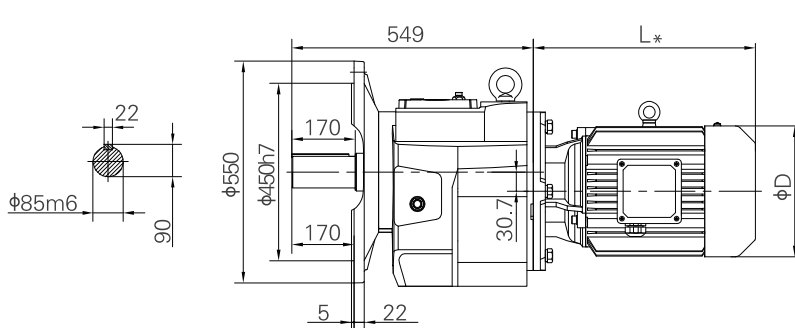

Flange-mounted

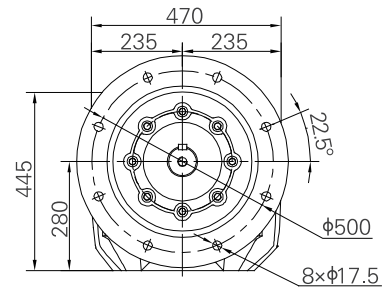

Weight: 205kg ( Without motor and oil )

**C212S  
C312S**

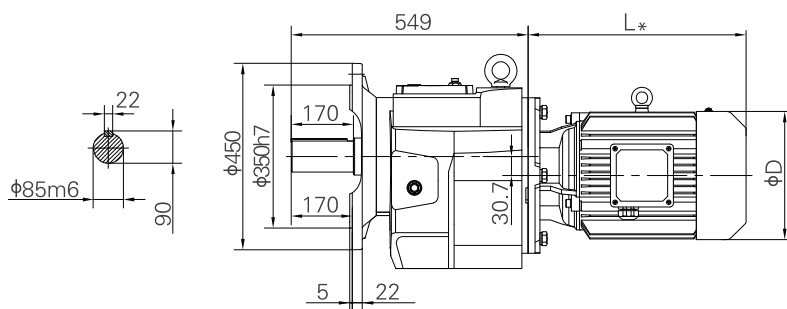

Short flange-mounted

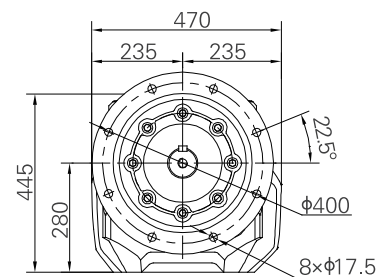

Weight: 195kg ( Without motor and oil )

### Corresponding motor dimension table for C212/C312

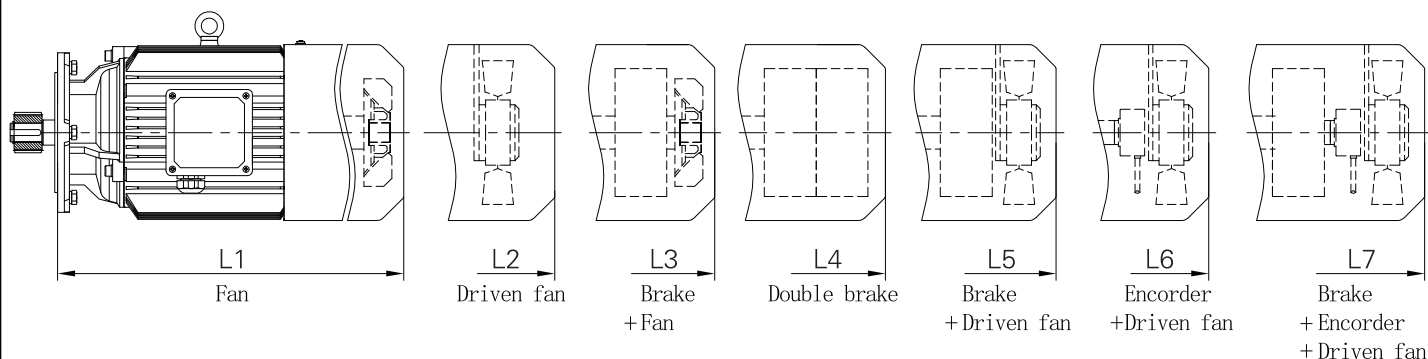

Directly connected motor dimension table

4-pole power (kW)	Range of Ratio	MS							MH							MP							MA							D
		L1	L2	L3	L4	L5	L6	L7	L1	L2	L3	L4	L5	L6	L7	L1	L2	L3	L5	L6	L7	L1	L2	L3	L5	L6	L7			
1.5	160-280	300	345	355	415	400	400	455	300	345	355	/	400	400	455	325	370	380	425	425	480	325	370	380	430	430	475	176		
2.2	112-280	370	410	445	505	485	485	540	370	410	445	/	485	485	540	370	410	445	485	485	540	370	425	445	505	505	550	202		
3	80-280	370	410	445	505	485	485	540	370	410	445	/	485	485	540	370	410	445	485	485	540	370	425	445	505	505	550	202		
4	63-280	366	416	441	501	491	491	546	434	484	509	/	559	559	614	434	484	509	559	559	614	434	494	509	574	574	614	220		
5.5	50-140	401	451	481	546	526	526	581	401	451	481	/	526	526	581	439	489	519	564	564	619	477	542	557	627	627	657	259		
7.5	35.5-140	439	489	519	584	564	564	619	439	489	519	/	564	564	619	477	527	557	602	602	657	477	542	557	627	627	657	259		
11	20-100	/	524	584	/	614	614	664	489	524	584	634	614	614	664	533	568	628	658	658	708	533	583	628	683	683	718	314		
15	16-71	/	568	628	/	658	658	708	533	568	628	678	658	658	708	563	598	658	688	688	738	563	613	658	713	713	748	314		
18.5	12.5-63	/	634	714	/	739	739	784	604	634	714	769	714	739	784	604	634	714	739	739	784	604	649	714	759	759	799	356		
22	11.2-56	/	682	762	/	787	787	832	652	682	762	817	762	787	832	652	682	762	787	787	832	652	697	762	807	807	847	356		
30	5.6-40	/	710	820	/	825	825	870	705	710	820	845	825	825	870	705	710	820	825	825	870	705	725	820	845	845	890	398		
37	4.5-31.5	/	776	861	/	891	891	936	746	776	861	/	891	891	936	746	776	861	891	891	936	746	781	861	901	901	941	446		
45	4.5-25	/	776	861	/	891	891	936	746	776	861	/	891	891	936	746	776	861	891	891	936	746	781	861	901	901	941	446		

Directly connected motor weight table / kg

4-pole power (kW)	Range of Ratio	MS							MH							MP							MA						
		M1	M2	M3	M4	M5	M6	M7	M1	M2	M3	M4	M5	M6	M7	M1	M2	M3	M5	M6	M7	M1	M2	M3	M5	M6	M7		
1.5	160-280	17	18	21	25	22	19	23	19	20	23	/	24	21	25	23	24	27	28	25	29	23	24	27	28	24.5	29		
2.2	112-280	27	28	35	42	36	29	37	30	31	38	/	39	32	40	32	33	40	41	34	42	36	37	44	45	38	45		
3	80-280	30	31	38	45	39	32	40	33	34	41	/	42	35	43	36	37	44	45	38	46	36	37	44	45	38	45		
4	63-280	45	46	53	61	54	47	55	52	53	60	/	61	54	62	56	57	64	65	58	66	56	57	64	65	58	66		
5.5	50-140	63	65	74	85	76	66	77	67	69	78	/	80	70	81	77	79	88	90	80	91	77	79	88	90	80	91		
7.5	35.5-140	73	75	84	95	86	76	87	80	82	91	/	93	83	94	88	90	99	101	91	102	88	90	99	101	91	102		
11	20-100	/	123	142	/	143	124	144	121	123	142	162	143	124	144	129	131	150	151	132	152	129	131	150	151	132	152		
15	16-71	/	141	160	/	161	142	162	139	141	160	180	161	142	162	161	163	182	183	164	184	161	163	182	183	164	184		
18.5	12.5-63	/	184	214	/	215	185	217	182	184	214	246	215	185	217	200	202	232	233	203	235	200	202	232	233	203	235		
22	11.2-56	/	206	236	/	237	207	239	204	206	236	268	237	207	239	220	222	252	253	223	255	220	222	252	253	223	255		
30	5.6-40	/	260	310	/	308	261	310	260	260	310	360	308	261	310	280	280	330	328	281	330	280	280	330	328	281	330		
37	4.5-31.5	/	332	380	/	381	334	383	330	332	380	/	381	334	383	345	347	395	396	349	398	345	347	395	396	349	398		
45	4.5-25	/	347	395	/	396	349	398	345	347	395	/	396	349	398	365	367	415	416	369	418	365	367	415	416	369	418		

**C213/C313 Dimensions**

**C213H  
C313H**

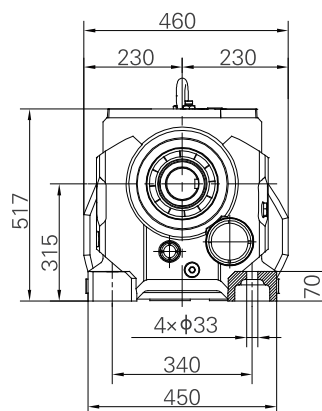
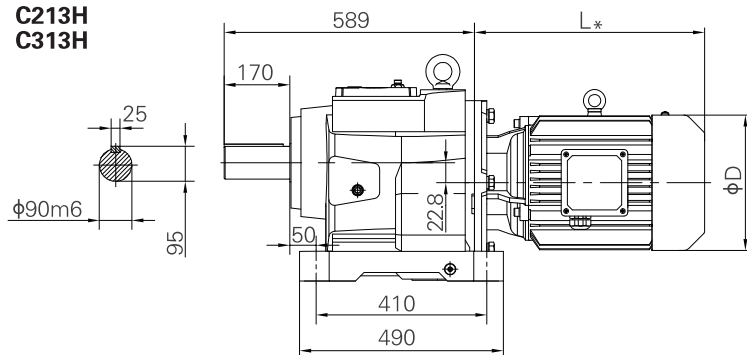

Horizontal foot-mounted

Weight: 255kg ( Without motor and oil )

**C213F  
C313F**

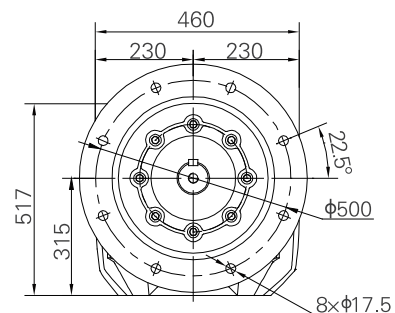
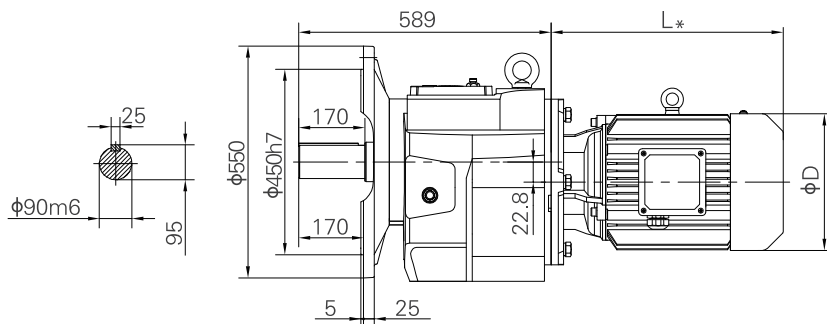

Flange-mounted

Weight: 278kg ( Without motor and oil )

**C213S  
C313S**

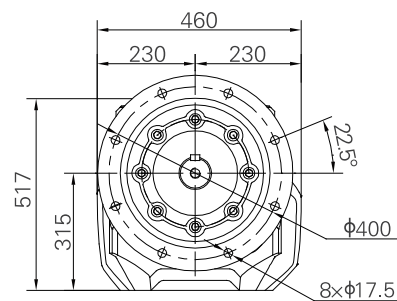
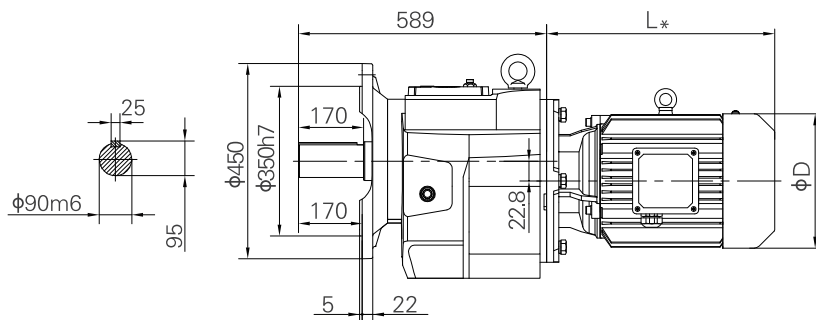

Short flange-mounted

Weight: 262kg ( Without motor and oil )

**Corresponding motor dimension table for C213/C313**

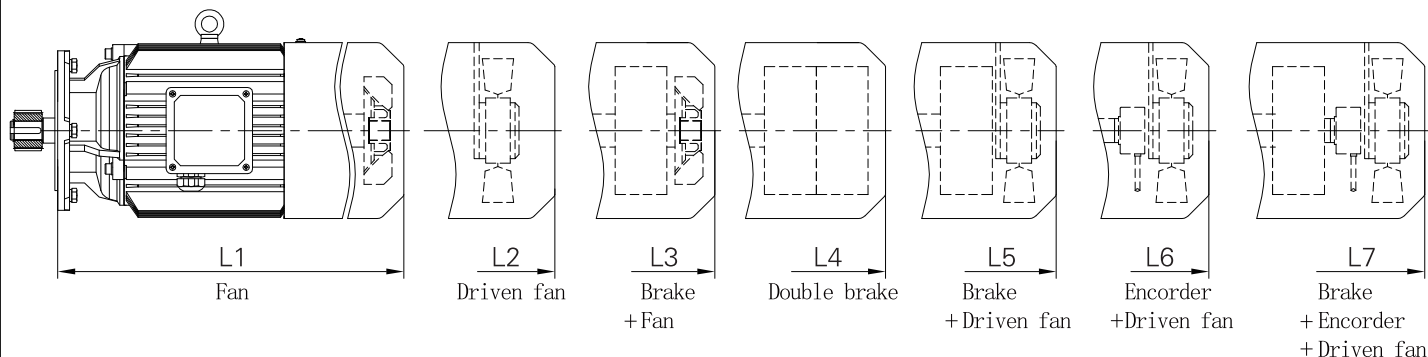

Directly connected motor dimension table

4-pole power (kW)	Range of Ratio	MS							MH							MP							MA							D
		L1	L2	L3	L4	L5	L6	L7	L1	L2	L3	L4	L5	L6	L7	L1	L2	L3	L5	L6	L7	L1	L2	L3	L5	L6	L7			
2.2	160-224	359	399	434	494	474	474	529	359	399	434	/	474	474	529	359	399	434	474	474	529	359	414	434	494	494	539	202		
3	112-224	359	399	434	494	474	474	529	359	399	434	/	474	474	529	359	399	434	474	474	529	359	414	434	494	494	539	202		
4	80-224	355	405	430	490	480	480	535	423	473	498	/	548	548	603	423	473	498	548	548	603	423	483	498	563	563	603	220		
5.5	56-125	391	441	471	536	516	516	571	391	441	471	/	516	516	571	429	479	509	554	554	609	467	532	547	617	617	647	259		
7.5	45-125	429	479	509	574	554	554	609	429	479	509	/	554	554	609	467	517	547	592	592	647	467	532	547	617	617	647	259		
11	28-125	/	508	568	/	598	598	648	473	508	568	618	598	598	648	517	552	612	642	642	692	517	567	612	667	667	702	314		
15	22.4-100	/	552	612	/	642	642	692	517	552	612	662	642	642	692	547	582	642	672	672	722	547	597	642	697	697	732	314		
18.5	18-80	/	618	698	/	723	723	768	588	618	698	753	698	723	768	588	618	698	723	723	768	588	633	698	743	743	783	356		
22	14-63	/	666	746	/	771	771	816	636	666	746	801	746	771	816	636	666	746	771	771	816	636	681	746	791	791	831	356		
30	10-50	/	689	799	/	804	804	849	684	689	799	824	804	804	849	684	689	799	804	804	849	684	704	799	824	824	869	398		
37	9-40	/	755	840	/	870	870	915	725	755	840	/	870	870	915	725	755	840	870	870	915	725	760	840	880	880	920	446		
45	4-31.5	/	755	840	/	870	870	915	725	755	840	/	870	870	915	725	755	840	870	870	915	725	760	840	880	880	920	446		
55	4-25	/	856	981	/	991	991	1026	841	856	981	/	991	991	1036	841	856	981	991	991	1036	841	866	981	1021	1021	1041	485		

Directly connected motor weight table / kg

4-pole power (kW)	Range of Ratio	MS							MH							MP							MA						
		M1	M2	M3	M4	M5	M6	M7	M1	M2	M3	M4	M5	M6	M7	M1	M2	M3	M5	M6	M7	M1	M2	M3	M5	M6	M7		
2.2	160-224	27	28	35	42	36	29	37	30	31	38	/	39	32	40	32	33	40	41	34	42	36	37	44	45	38	45		
3	112-224	30	31	38	45	39	32	40	33	34	41	/	42	35	43	36	37	44	45	38	46	36	37	44	45	38	45		
4	80-224	45	46	53	61	54	47	55	52	53	60	/	61	54	62	56	57	64	65	58	66	56	57	64	65	58	66		
5.5	56-125	63	65	74	85	76	66	77	67	69	78	/	80	70	81	77	79	88	90	80	91	77	79	88	90	80	91		
7.5	45-125	73	75	84	95	86	76	87	80	82	91	/	93	83	94	88	90	99	101	91	102	88	90	99	101	91	102		
11	28-125	/	123	142	/	143	124	144	121	123	142	162	143	124	144	129	131	150	151	132	152	129	131	150	151	132	152		
15	22.4-100	/	141	160	/	161	142	162	139	141	160	180	161	142	162	161	163	182	183	164	184	161	163	182	183	164	184		
18.5	18-80	/	184	214	/	215	185	217	182	184	214	246	215	185	217	200	202	232	233	203	235	200	202	232	233	203	235		
22	14-63	/	206	236	/	237	207	239	204	206	236	268	237	207	239	220	222	252	253	223	255	220	222	252	253	223	255		
30	10-50	/	260	310	/	308	261	310	260	260	310	360	308	261	310	280	280	330	328	281	330	280	280	330	328	281	330		
37	9-40	/	332	380	/	381	334	383	330	332	380	/	381	334	383	345	347	395	396	349	398	345	347	395	396	349	398		
45	4-31.5	/	347	395	/	396	349	398	345	347	395	/	396	349	398	365	367	415	416	369	418	365	367	415	416	369	418		
55	4-25	/	436	540	/	535	436	537	435	436	540	/	535	436	537	470	471	575	570	471	572	470	471	575	570	470	572		



**C214/C314 Dimensions**

**C214H  
C314H**

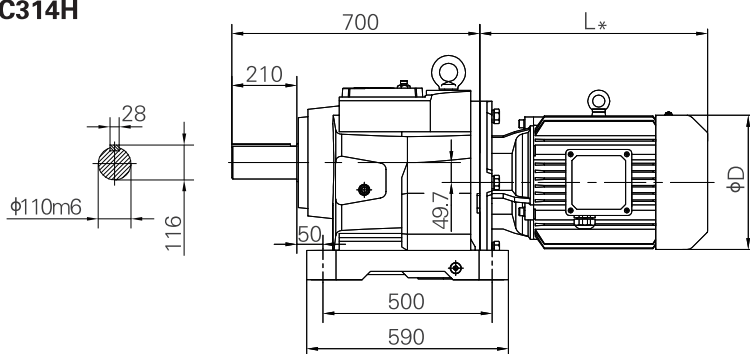

Horizontal foot-mounted

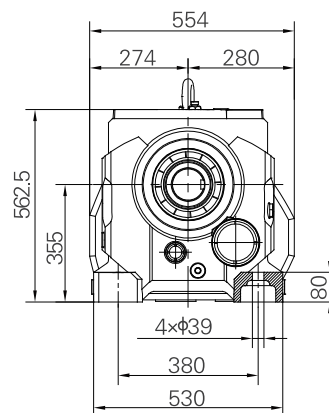

Weight: 365kg ( Without motor and oil )

**C214F  
C314F**

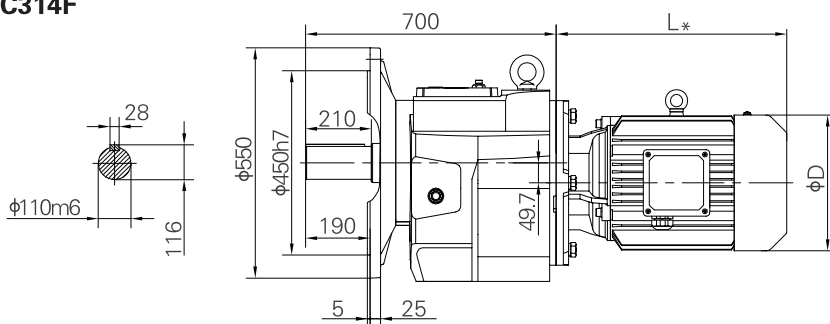

Flange-mounted

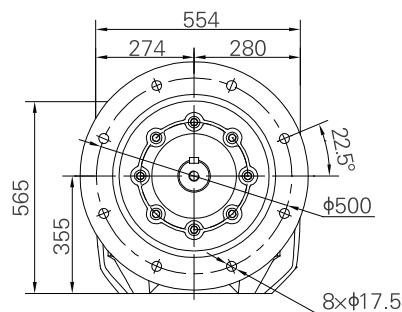

Weight: 395kg ( Without motor and oil )

**C214S  
C314S**

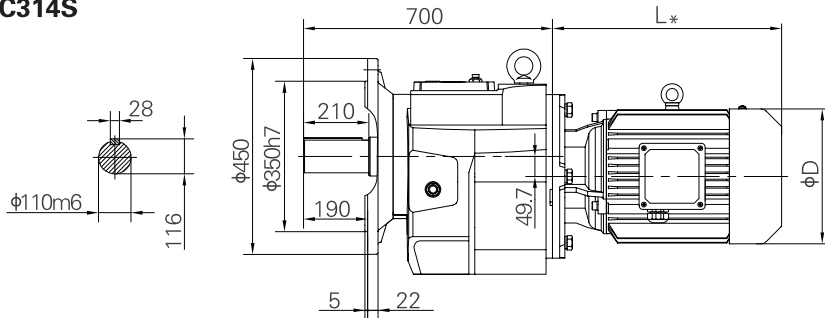

Short flange-mounted

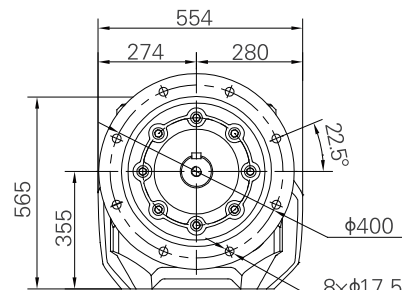

Weight: 380kg ( Without motor and oil )

**Corresponding motor dimension table for C214/C314**

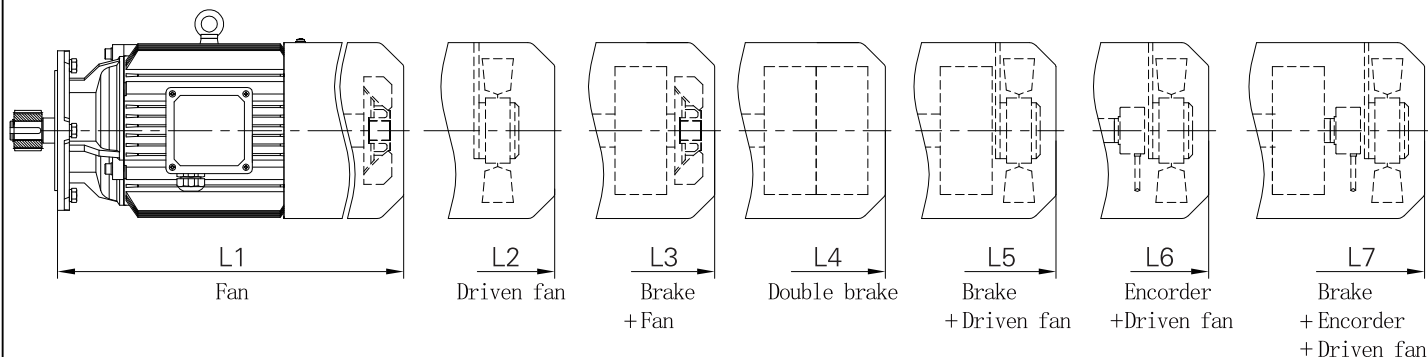

Directly connected motor dimension table

4-pole power (kW)	Range of Ratio	MS							MH							MP							MA							D
		L1	L2	L3	L4	L5	L6	L7	L1	L2	L3	L4	L5	L6	L7	L1	L2	L3	L5	L6	L7	L1	L2	L3	L5	L6	L7			
2.2	250-280	359	399	434	494	474	474	529	359	399	434	/	474	474	529	359	399	434	474	474	529	359	414	434	494	494	539	202		
3	180-280	359	399	434	494	474	474	529	359	399	434	/	474	474	529	359	399	434	474	474	529	359	414	434	494	494	539	202		
4	140-280	355	405	430	490	480	480	535	423	473	498	/	548	548	603	423	473	498	548	548	603	423	483	498	563	563	603	220		
5.5	100-200	391	441	471	536	516	516	571	391	441	471	/	516	516	571	429	479	509	554	554	609	467	532	547	617	617	647	259		
7.5	71-200	429	479	509	574	554	554	609	429	479	509	/	554	554	609	467	517	547	592	592	647	467	532	547	617	617	647	259		
11	50-200	/	508	568	/	598	598	648	473	508	568	618	598	598	648	517	552	612	642	642	692	517	567	612	667	667	702	314		
15	35.5-160	/	552	612	/	642	642	692	517	552	612	662	642	642	692	547	582	642	672	672	722	547	597	642	697	697	732	314		
18.5	28-140	/	618	698	/	723	723	768	588	618	698	753	698	723	768	588	618	698	723	723	768	588	633	698	743	743	783	356		
22	25-112	/	666	746	/	771	771	816	636	666	746	801	746	771	816	636	666	746	771	771	816	636	681	746	791	791	831	356		
30	18-80	/	689	799	/	804	804	849	684	689	799	824	804	804	849	684	689	799	804	804	849	684	704	799	824	824	869	398		
37	14-71	/	755	840	/	870	870	915	725	755	840	/	870	870	915	725	755	840	870	870	915	725	760	840	880	880	920	446		
45	12.5-56	/	755	840	/	870	870	915	725	755	840	/	870	870	915	725	755	840	870	870	915	725	760	840	880	880	920	446		
55	10-45	/	856	981	/	991	991	1026	841	856	981	/	991	991	1036	841	856	981	991	991	1036	841	866	981	1021	1021	1041	485		
75	5.6-31.5	/	916	1026	/	1061	1061	1106	886	916	1026	/	1061	1061	1106	886	916	1026	1061	1061	1106	886	916	1026	1066	1066	1106	547		
90	4.5-25	/	967	1077	/	1112	1112	1157	937	967	1077	/	1112	1112	1157	937	967	1077	1112	1112	1157	937	967	1077	1117	1117	1157	547		

Directly connected motor weight table / kg

4-pole power (kW)	Range of Ratio	MS							MH							MP							MA						
		M1	M2	M3	M4	M5	M6	M7	M1	M2	M3	M4	M5	M6	M7	M1	M2	M3	M5	M6	M7	M1	M2	M3	M5	M6	M7		
2.2	250-280	27	28	35	42	36	29	37	30	31	38	/	39	32	40	32	33	40	41	34	42	36	37	44	45	38	45		
3	180-280	30	31	38	45	39	32	40	33	34	41	/	42	35	43	36	37	44	45	38	46	36	37	44	45	38	45		
4	140-280	45	46	53	61	54	47	55	52	53	60	/	61	54	62	56	57	64	65	58	66	56	57	64	65	58	66		
5.5	100-200	63	65	74	85	76	66	77	67	69	78	/	80	70	81	77	79	88	90	80	91	77	79	88	90	80	91		
7.5	71-200	73	75	84	95	86	76	87	80	82	91	/	93	83	94	88	90	99	101	91	102	88	90	99	101	91	102		
11	50-200	/	123	142	/	143	124	144	121	123	142	162	143	124	144	129	131	150	151	132	152	129	131	150	151	132	152		
15	35.5-160	/	141	160	/	161	142	162	139	141	160	180	161	142	162	161	163	182	183	164	184	161	163	182	183	164	184		
18.5	28-140	/	184	214	/	215	185	217	182	184	214	246	215	185	217	200	202	232	233	203	235	200	202	232	233	203	235		
22	25-112	/	206	236	/	237	207	239	204	206	236	268	237	207	239	220	222	252	253	223	255	220	222	252	253	223	255		
30	18-80	/	260	310	/	308	261	310	260	260	310	360	308	261	310	280	280	330	328	281	330	280	280	330	328	281	330		
37	14-71	/	332	380	/	381	334	383	330	332	380	/	381	334	383	345	347	395	396	349	398	345	347	395	396	349	398		
45	12.5-56	/	347	395	/	396	349	398	345	347	395	/	396	349	398	365	367	415	416	369	418	365	367	415	416	369	418		
55	10-45	/	436	540	/	535	436	537	435	436	540	/	535	436	537	470	471	575	570	471	572	470	471	575	570	470	572		
75	5.6-31.5	/	577	680	/	678	578	680	575	577	680	/	678	578	680	630	632	735	733	633	735	630	632	735	733	633	735		
90	4.5-25	/	647	750	/	748	648	750	645	647	750	/	748	648	750	710	712	815	813	713	815	710	712	815	813	713	815		

**C216/C316 Dimensions**

**C216H  
C316H**

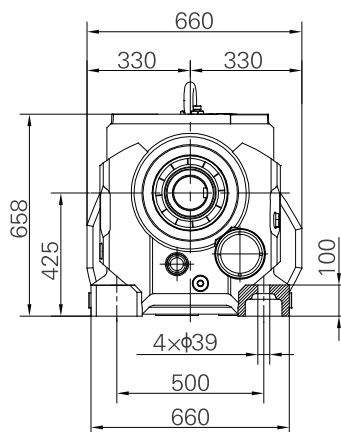
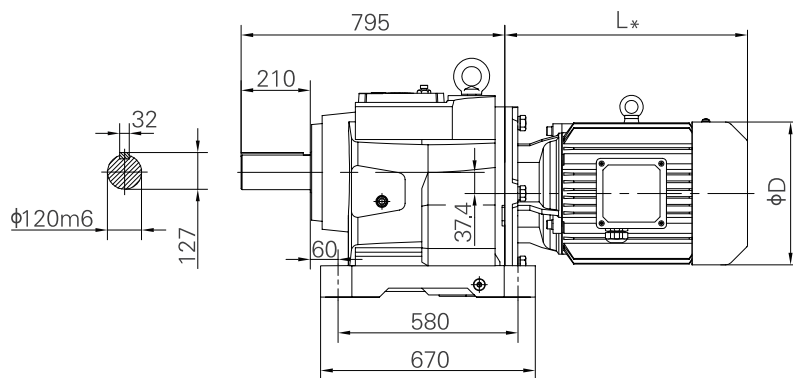

Horizontal foot-mounted

Weight: 615kg ( Without motor and oil )

**C216F  
C316F**

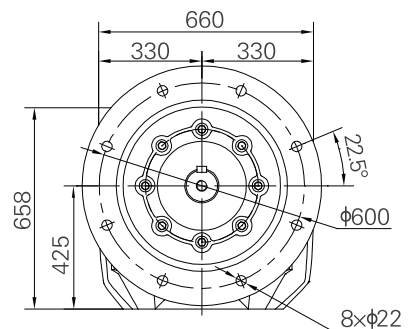
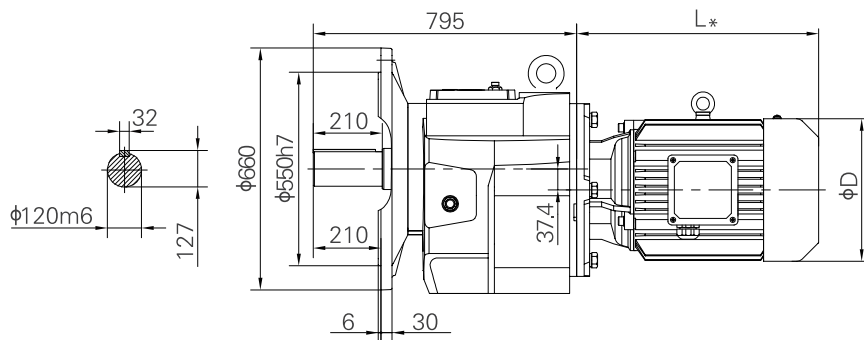

Flange-mounted

Weight: 645kg ( Without motor and oil )

**Corresponding motor dimension table for C216/C316**

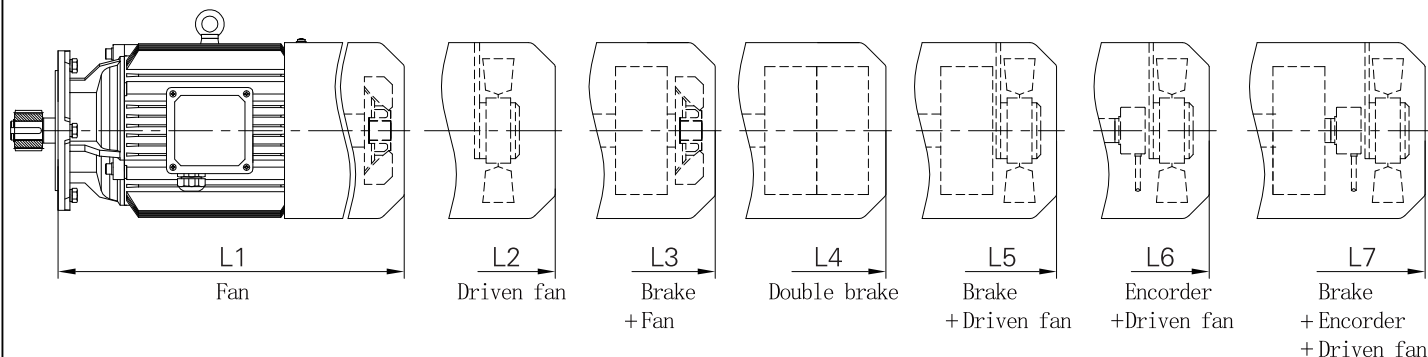

Directly connected motor dimension table

4-pole power (kW)	Range of Ratio	MS							MH							MP							MA							D
		L1	L2	L3	L4	L5	L6	L7	L1	L2	L3	L4	L5	L6	L7	L1	L2	L3	L5	L6	L7	L1	L2	L3	L5	L6	L7			
7.5	100-224	429	479	509	574	554	554	609	429	479	509	/	554	554	609	467	517	547	592	592	647	467	532	547	617	617	647	259		
11	71-224	/	493	553	/	583	583	633	458	493	553	603	583	583	633	502	537	597	627	627	677	502	552	597	652	652	687	314		
15	50-224	/	537	597	/	627	627	677	502	537	597	647	627	627	677	532	567	627	657	657	707	532	582	627	682	682	717	314		
18.5	40-180	/	603	683	/	708	708	753	573	603	683	738	683	708	753	573	603	683	708	708	753	573	618	683	728	728	768	356		
22	35.5-160	/	651	731	/	756	756	801	621	651	731	786	731	756	801	621	651	731	756	756	801	621	666	731	776	776	816	356		
30	25-112	/	679	789	/	794	794	839	674	679	789	814	794	794	839	674	679	789	794	794	839	674	694	789	814	814	859	398		
37	20-90	/	745	830	/	860	860	905	715	745	830	/	860	860	905	715	745	830	860	860	905	715	750	830	870	870	910	446		
45	16-80	/	745	830	/	860	860	905	715	745	830	/	860	860	905	715	745	830	860	860	905	715	750	830	870	870	910	446		
55	12.5-63	/	846	971	/	981	981	1016	831	846	971	/	981	981	1026	831	846	971	981	981	1026	831	856	971	1011	1011	1031	485		
75	9-45	/	906	1016	/	1051	1051	1096	876	906	1016	/	1051	1051	1096	876	906	1016	1051	1051	1096	876	906	1016	1056	1056	1096	547		
90	7.1-35.5	/	957	1067	/	1102	1102	1147	927	957	1067	/	1102	1102	1147	927	957	1067	1102	1102	1147	927	957	1067	1107	1107	1147	547		

Directly connected motor weight table / kg

4-pole power (kW)	Range of Ratio	MS							MH							MP							MA						
		M1	M2	M3	M4	M5	M6	M7	M1	M2	M3	M4	M5	M6	M7	M1	M2	M3	M5	M6	M7	M1	M2	M3	M5	M6	M7		
7.5	100-224	73	75	84	95	86	76	87	80	82	91	/	93	83	94	88	90	99	101	91	102	88	90	99	101	91	102		
11	71-224	/	123	142	/	143	124	144	121	123	142	162	143	124	144	129	131	150	151	132	152	129	131	150	151	132	152		
15	50-224	/	141	160	/	161	142	162	139	141	160	180	161	142	162	161	163	182	183	164	184	161	163	182	183	164	184		
18.5	40-180	/	184	214	/	215	185	217	182	184	214	246	215	185	217	200	202	232	233	203	235	200	202	232	233	203	235		
22	35.5-160	/	206	236	/	237	207	239	204	206	236	268	237	207	239	220	222	252	253	223	255	220	222	252	253	223	255		
30	25-112	/	260	310	/	308	261	310	260	260	310	360	308	261	310	280	280	330	328	281	330	280	280	330	328	281	330		
37	20-90	/	332	380	/	381	334	383	330	332	380	/	381	334	383	345	347	395	396	349	398	345	347	395	396	349	398		
45	16-80	/	347	395	/	396	349	398	345	347	395	/	396	349	398	365	367	415	416	369	418	365	367	415	416	369	418		
55	12.5-63	/	436	540	/	535	436	537	435	436	540	/	535	436	537	470	471	575	570	471	572	470	471	575	570	470	572		
75	9-45	/	577	680	/	678	578	680	575	577	680	/	678	578	680	630	632	735	733	633	735	630	632	735	733	633	735		
90	7.1-35.5	/	647	750	/	748	648	750	645	647	750	/	748	648	750	710	712	815	813	713	815	710	712	815	813	713	815		

## 7 Input Flange and Input Shaft

### 7.1 C series dimensions of AP input flange

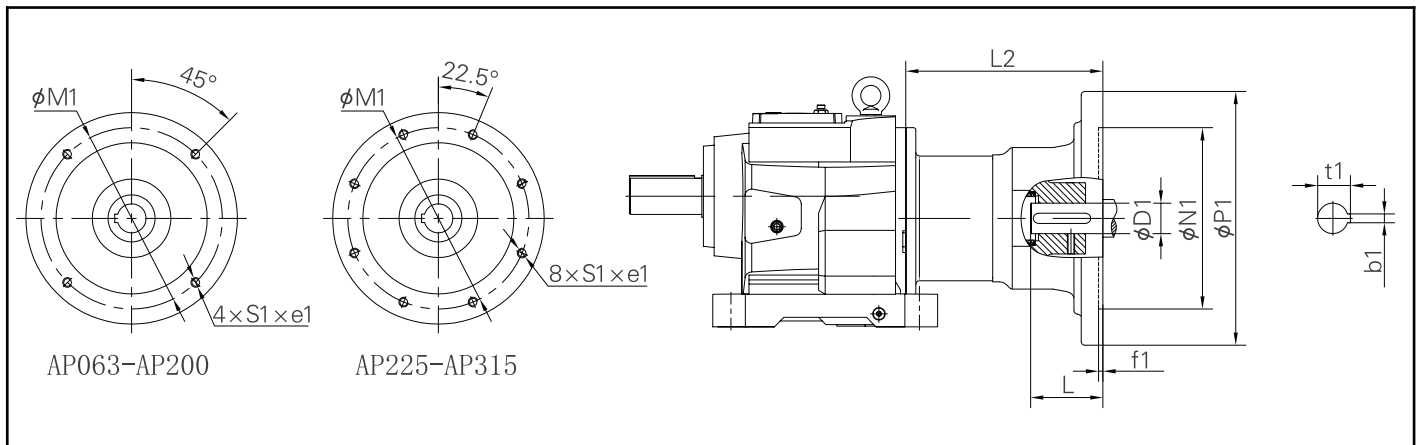

Size	Flange	Range of Ratio	e1	D1	N1	M1	P1	f1	b1	t1	L	S1	L2	Weight (kg)
C203 C303	AP063	4-90	14	11H7	95H7	115	140	4	4	12.8	23	M8	59	4.8
	AP071	4-90	14	14H7	110H7	130	160	4	5	16.3	30	M8	59	4.8
	AP080	4-71	18	19H7	130H7	165	200	4	6	21.8	40	M10	74	7.6
C204 C304	AP063	4-125	14	11H7	95H7	115	140	4	4	12.8	23	M8	61	5.1
	AP071	4-125	14	14H7	110H7	130	160	4	5	16.3	30	M8	61	5.1
	AP080	4-100	18	19H7	130H7	165	200	4	6	21.8	40	M10	76	8.6
	AP090	4-50	18	24H7	130H7	165	200	4	8	27.3	50	M10	81	9.2
	AP100	4-25	28	28H7	180H7	215	250	5	8	31.3	60	M12	191	14.1
	AP112	4-11.2	28	28H7	180H7	215	250	5	8	31.3	60	M12	191	14.1
C205 C305	AP063	4.5-140	14	11H7	95H7	115	140	4	4	12.8	23	M8	61	5.1
	AP071	4.5-140	14	14H7	110H7	130	160	4	5	16.3	30	M8	61	5.1
	AP080	4.5-140	18	19H7	130H7	165	200	4	6	21.8	40	M10	76	8.6
	AP090	4.5-80	18	24H7	130H7	165	200	4	8	27.3	50	M10	81	9.2
	AP100	4.5-40	28	28H7	180H7	215	250	5	8	31.3	60	M12	191	14.1
	AP112	4.5-22.4	28	28H7	180H7	215	250	5	8	31.3	60	M12	191	14.1
C206 C306	AP063	4.5-160	14	11H7	95H7	115	140	4	4	12.8	23	M8	61	5.1
	AP071	4.5-160	14	14H7	110H7	130	160	4	5	16.3	30	M8	61	5.1
	AP080	4.5-160	18	19H7	130H7	165	200	4	6	21.8	40	M10	76	8.6
	AP090	4.5-100	18	24H7	130H7	165	200	4	8	27.3	50	M10	81	9.2
	AP100	4.5-56	28	28H7	180H7	215	250	5	8	31.3	60	M12	191	14.1
	AP112	4.5-31.5	28	28H7	180H7	215	250	5	8	31.3	60	M12	191	14.1
C207 C307	AP071	4-180	14	14H7	110H7	130	160	4	5	16.3	30	M8	53	6.7
	AP080	4-180	18	19H7	130H7	165	200	4	6	21.8	40	M10	68	10.3
	AP090	4-100	18	24H7	130H7	165	200	4	8	27.3	50	M10	73	11.1
	AP100	4-71	28	28H7	180H7	215	250	5	8	31.3	60	M12	181	15.5
	AP112	4-40	28	28H7	180H7	215	250	5	8	31.3	60	M12	181	15.5
	AP132	4-28	28	38H7	230H7	265	300	5	10	41.3	80	M12	210	22.3
C208 C308	AP080	20-200	18	19H7	130H7	165	200	4	6	21.8	40	M10	65	10.4
	AP090	4.5-200	18	24H7	130H7	165	200	4	8	27.3	50	M10	66	12.1
	AP100	4.5-125	28	28H7	180H7	215	250	5	8	31.3	60	M12	171	18.2
	AP112	4.5-80	28	28H7	180H7	215	250	5	8	31.3	60	M12	171	18.2
	AP132	4.5-56	28	38H7	230H7	265	300	5	10	41.3	80	M12	203	24.9
	AP160	4.5-28	40	42H7	250H7	300	350	6	12	45.3	110	M16	272	46.4
AP180	4.5-12.5	40	48H7	250H7	300	350	6	14	51.8	110	M16	272	46.4	

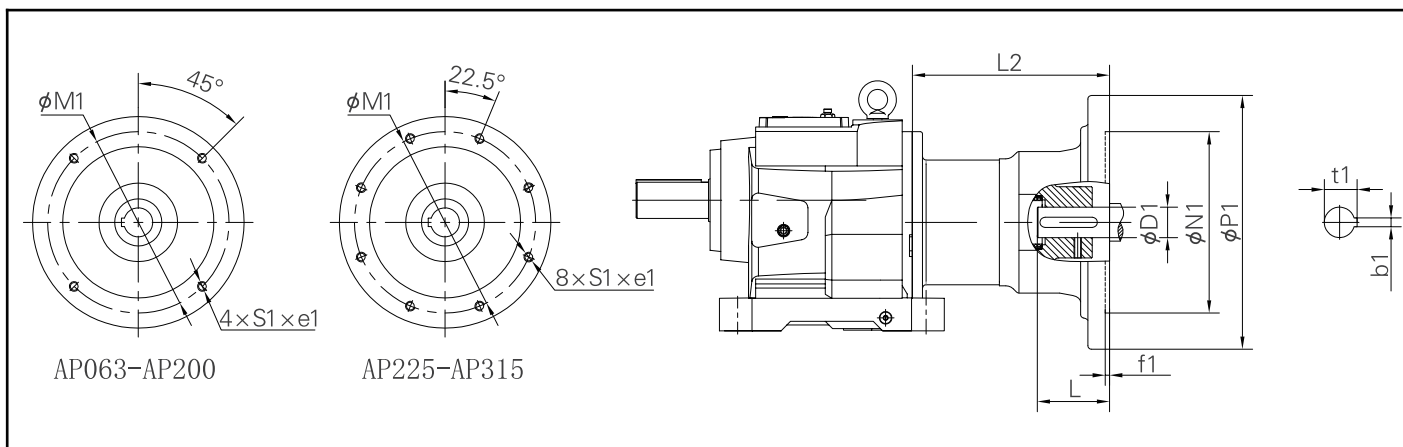

Size	Flange	Range of Ratio	e1	D1	N1	M1	P1	f1	b1	t1	L	S1	L2	Weight(kg)
C209 C309	AP090	4-224	18	24H7	130H7	165	200	4	8	27.3	50	M10	70	14.7
	AP100	4-224	28	28H7	180H7	215	250	5	8	31.3	60	M12	172	21.5
	AP112	4-125	28	28H7	180H7	215	250	5	8	31.3	60	M12	172	21.5
	AP132	4-125	28	38H7	230H7	265	300	5	10	41.3	80	M12	202	28.3
	AP160	4-56	40	42H7	250H7	300	350	6	12	45.3	110	M16	270	49.9
	AP180	4-31.5	40	48H7	250H7	300	350	6	14	51.8	110	M16	270	49.9
C210 C310	AP200	4-16	40	55H7	300H7	350	400	6	16	59.3	110	M16	327	72.8
	AP100	4-224	28	28H7	180H7	215	250	5	8	31.3	60	M12	162	25.6
	AP112	4-200	28	28H7	180H7	215	250	5	8	31.3	60	M12	162	25.6
	AP132	4-140	28	38H7	230H7	265	300	5	10	41.3	80	M12	189	33.7
	AP160	4-71	40	42H7	250H7	300	350	6	12	45.3	110	M16	257	52.3
	AP180	4-45	40	48H7	250H7	300	350	6	14	51.8	110	M16	257	52.3
C212 C312	AP200	4-28	40	55H7	300H7	350	400	6	16	59.3	110	M16	327	77.4
	AP225	4-22.4	30	60H7	350H7	400	450	6	18	64.4	140	M16	354	85.1
	AP100	4.5-280	28	28H7	180H7	215	250	5	8	31.3	60	M12	162	25.6
	AP112	4.5-280	28	28H7	180H7	215	250	5	8	31.3	60	M12	162	25.6
	AP132	4.5-140	28	38H7	230H7	265	300	5	10	41.3	80	M12	189	33.7
	AP160	4.5-100	40	42H7	250H7	300	350	6	12	45.3	110	M16	257	52.3
C213 C313	AP180	4.5-63	40	48H7	250H7	300	350	6	14	51.8	110	M16	257	52.3
	AP200	4.5-40	40	55H7	300H7	350	400	6	16	59.3	110	M16	327	77.4
	AP225	4.5-31.5	30	60H7	350H7	400	450	6	18	64.4	140	M16	354	85.1
	AP132	4-125	28	38H7	230H7	265	300	5	10	41.3	80	M12	175	46.4
	AP160	4-125	40	42H7	250H7	300	350	6	12	45.3	110	M16	243	66.9
	AP180	4-80	40	48H7	250H7	300	350	6	14	51.8	110	M16	243	66.9
C214 C314	AP200	4-50	40	55H7	300H7	350	400	6	16	59.3	110	M16	316	89.8
	AP225	4-40	30	60H7	350H7	400	450	6	18	64.4	140	M16	343	97.5
	AP250	4-20	32	65H7	450H7	500	550	7	18	69.4	140	M16	361	131.3
	AP132	4-200	28	38H7	230H7	265	300	5	10	41.3	80	M12	175	46.4
	AP160	4-200	40	42H7	250H7	300	350	6	12	45.3	110	M16	243	66.9
	AP180	4-140	40	48H7	250H7	300	350	6	14	51.8	110	M16	243	66.9
	AP200	4-80	40	55H7	300H7	350	400	6	16	59.3	110	M16	316	89.8
C216 C316	AP225	4-71	30	60H7	350H7	400	450	6	18	64.4	140	M16	343	97.5
	AP250	4-45	32	65H7	450H7	500	550	7	18	69.4	140	M16	361	131.3
	AP280	4-31.5	32	75H7	450H7	500	550	7	20	79.9	140	M16	361	131.3
	AP160	18-224	40	42H7	250H7	300	350	6	12	45.3	110	M16	233	90.9
	AP180	18-180	40	48H7	250H7	300	350	6	14	51.8	110	M16	233	90.9
	AP200	4.5-112	40	55H7	300H7	350	400	6	16	59.3	110	M16	298	109.4
C216 C316	AP225	4.5-90	30	60H7	350H7	400	450	6	18	64.4	140	M16	325	117.1
	AP250	4.5-63	32	65H7	450H7	500	550	7	18	69.4	140	M16	343	147.8
	AP280	4.5-45	32	75H7	450H7	500	550	7	20	79.9	140	M16	343	147.8
	AP315	4.5-31.5	35	80H7	550H7	600	660	7	22	85.4	170	M20	447	262.5

## 7.2 C series dimensions of AS input flange

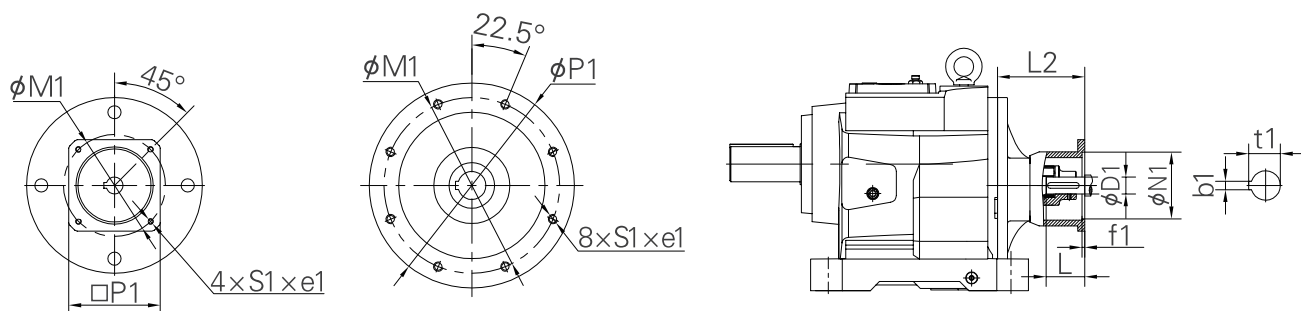

AS040-AS315

AS450

Size	Flange	Range of Ratio	e1	D1	N1	M1	P1	f1	b1	t1	L	S1	L2	Weight(kg)
C203 C303	AS040	4-90	4	8H7	30H7	46	78	4	2	9	25	M4	65	2.5
	AS055	4-90	4	9H7	40H7	63	78	4	3	10.4	25	M5	65	2.5
	AS060	4-90	10	14H7	50H7	70	60	4	5	16.3	30	M5	114	3.2
	AS070	4-90	10	14H7	60H7	75	70	4	5	16.3	30	M5	114	3.3
	AS080	4-90	10	19H7	70H7	90	80	4	6	21.8	35	M6	120	3.4
	AS090	4-90	10	19H7	80H7	100	90	4	6	21.8	40	M6	125	3.6
	AS100	4-50	14	19H7	95H7	115	100	4	6	21.8	45	M8	122	3.9
	AS125	4-50	15	24H7	110H7	130	130	5	8	27	50	M8	133	4.9
C204 C304	AS140	4-50	15	24H7	110H7	145	130	5.5	8	27	55	M8	133	4.8
	AS060	4-125	10	14H7	50H7	70	60	4	5	16.3	30	M5	116	4.1
	AS070	4-125	10	14H7	60H7	75	70	4	5	16.3	30	M5	116	4.2
	AS080	4-125	10	19H7	70H7	90	80	4	6	21.8	35	M6	122	4.3
	AS090	4-125	10	19H7	80H7	100	90	4	6	21.8	40	M6	127	4.5
	AS100	4-71	14	19H7	95H7	115	100	4	6	21.8	45	M8	124	4.8
	AS125	4-71	15	24H7	110H7	130	130	5	8	27	50	M8	135	5.8
	AS140	4-71	15	24H7	110H7	145	130	5.5	8	27	55	M8	135	5.7
C205 C305	AS160	4-71	15	32H7	130H7	165	155	5	10	35.3	60	M10	190	9.9
	AS060	4.5-140	10	14H7	50H7	70	60	4	5	16.3	30	M5	116	4.1
	AS070	4.5-140	10	14H7	60H7	75	70	4	5	16.3	30	M5	116	4.2
	AS080	4.5-140	10	19H7	70H7	90	80	4	6	21.8	35	M6	122	4.3
	AS090	4.5-140	10	19H7	80H7	100	90	4	6	21.8	40	M6	127	4.5
	AS100	4.5-80	14	19H7	95H7	115	100	4	6	21.8	45	M8	124	4.8
	AS125	4.5-80	15	24H7	110H7	130	130	5	8	27	50	M8	135	5.8
	AS140	4.5-80	15	24H7	110H7	145	130	5.5	8	27	55	M8	135	5.7
C206 C306	AS160	4.5-80	15	32H7	130H7	165	155	5	10	35.3	60	M10	190	9.9
	AS060	4.5-160	10	14H7	50H7	70	60	4	5	16.3	30	M5	116	4.1
	AS070	4.5-160	10	14H7	60H7	75	70	4	5	16.3	30	M5	116	4.2
	AS080	4.5-160	10	19H7	70H7	90	80	4	6	21.8	35	M6	122	4.3
	AS090	4.5-160	10	19H7	80H7	100	90	4	6	21.8	40	M6	127	4.5
	AS100	4.5-100	14	19H7	95H7	115	100	4	6	21.8	45	M8	124	4.8
	AS125	4.5-100	15	24H7	110H7	130	130	5	8	27	50	M8	135	5.8
	AS140	4.5-100	15	24H7	110H7	145	130	5.5	8	27	55	M8	135	5.7
C207 C307	AS160	4.5-100	15	32H7	130H7	165	155	5	10	35.3	60	M10	190	9.9
	AS060	4-180	10	14H7	50H7	70	60	4	5	16.3	30	M5	108	5.6
	AS070	4-180	10	14H7	60H7	75	70	4	5	16.3	30	M5	108	5.7
	AS080	4-180	10	19H7	70H7	90	80	4	6	21.8	35	M6	114	5.8
	AS090	4-180	10	19H7	80H7	100	90	4	6	21.8	40	M6	119	6
	AS100	4-100	14	19H7	95H7	115	100	4	6	21.8	45	M8	116	6.3
	AS125	4-100	15	24H7	110H7	130	130	5	8	27	50	M8	127	7.3
	AS140	4-100	15	24H7	110H7	145	130	5.5	8	27	55	M8	127	7.2
	AS160	4-100	15	32H7	130H7	165	155	5	10	35.3	60	M10	180	11.3
	AS180	4-31.5	16	35H7	114.3H7	200	180	7	10	38.3	80	M12	210	16.7
AS190	4-31.5	18	38H7	180H7	215	190	5	10	41.3	80	M12	210	17.1	
AS240	4-31.5	28	38H7	230H7	265	240	5	10	41.3	80	M12	210	22.3	

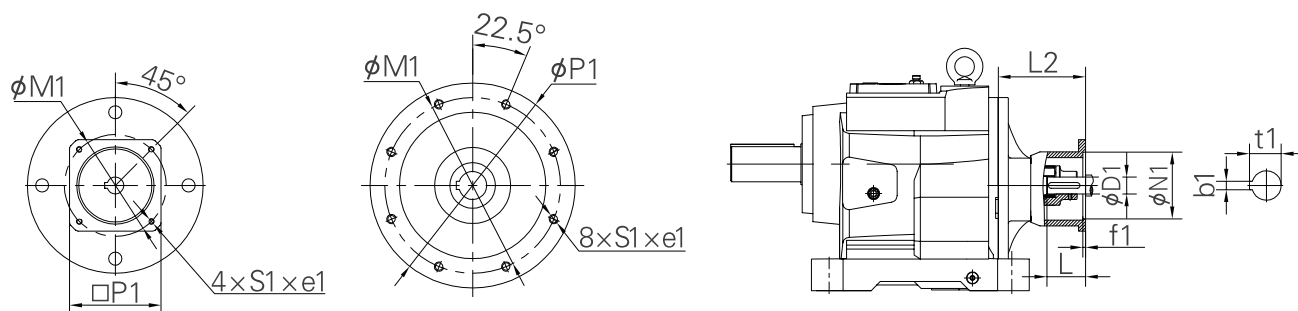

AS040-AS315

AS450

Size	Flange	Range of Ratio	e1	D1	N1	M1	P1	f1	b1	t1	L	S1	L2	Weight(kg)
C208 C308	AS070	20-200	10	14H7	60H7	75	70	4	5	16.3	30	M5	105	8
	AS080	20-200	10	19H7	70H7	90	80	4	6	21.8	35	M6	111	8.1
	AS090	20-200	10	19H7	80H7	100	90	4	6	21.8	40	M6	116	8.3
	AS100	4.5-160	14	19H7	95H7	115	100	4	6	21.8	45	M8	113	8.6
	AS125	4.5-160	15	24H7	110H7	130	130	5	8	27	50	M8	124	9.6
	AS140	4.5-160	15	24H7	110H7	145	130	5.5	8	27	55	M8	124	9.5
	AS160	4.5-160	15	32H7	130H7	165	155	5	10	35.3	60	M10	170	14
	AS180	4.5-71	16	35H7	114.3H7	200	180	7	10	38.3	80	M12	203	19.3
	AS190	4.5-71	18	38H7	180H7	215	190	5	10	41.3	80	M12	203	19.7
	AS240	4.5-71	28	38H7	230H7	265	240	5	10	41.3	80	M12	203	24.9
AS260	4.5-71	40	48H7	250H7	300	260	6	14	51.8	110	M16	272	46.4	
C209 C309	AS160	4-224	15	32H7	130H7	165	155	5	10	35.3	60	M10	171	17.3
	AS180	4-112	16	35H7	114.3H7	200	180	7	10	38.3	80	M12	202	22.7
	AS190	4-112	18	38H7	180H7	215	190	5	10	41.3	80	M12	202	23.1
	AS240	4-112	28	38H7	230H7	265	240	5	10	41.3	80	M12	202	28.3
	AS260	4-112	40	48H7	250H7	300	260	6	14	51.8	110	M16	271	49.9
C210 C310	AS160	4-224	15	32H7	130H7	165	155	5	10	35.3	60	M10	161	21.4
	AS180	4-140	16	35H7	114.3H7	200	180	7	10	38.3	80	M12	189	28.1
	AS190	4-140	18	38H7	180H7	215	190	5	10	41.3	80	M12	189	28.5
	AS240	4-140	28	38H7	230H7	265	240	5	10	41.3	80	M12	189	33.7
	AS260	4-140	40	48H7	250H7	300	260	6	14	51.8	110	M16	258	52.3
	AS315	4-100	40	55H7	300H7	350	315	6	16	59.3	110	M16	327	77.4
C212 C312	AS160	4.5-280	15	32H7	130H7	165	155	5	10	35.3	60	M10	161	21.4
	AS180	4.5-140	16	35H7	114.3H7	200	180	7	10	38.3	80	M12	189	28.1
	AS190	4.5-140	18	38H7	180H7	215	190	5	10	41.3	80	M12	189	28.5
	AS240	4.5-140	28	38H7	230H7	265	240	5	10	41.3	80	M12	189	33.7
	AS260	4.5-140	40	48H7	250H7	300	260	6	14	51.8	110	M16	258	52.3
	AS315	4.5-100	40	55H7	300H7	350	315	6	16	59.3	110	M16	327	77.4
C213 C313	AS180	4-125	16	35H7	114.3H7	200	180	7	10	38.3	80	M12	175	40.8
	AS190	4-125	18	38H7	180H7	215	190	5	10	41.3	80	M12	175	41.2
	AS240	4-125	28	38H7	230H7	265	240	5	10	41.3	80	M12	175	46.4
	AS260	4-125	40	48H7	250H7	300	260	6	14	51.8	110	M16	244	66.9
	AS315	4-100	40	55H7	300H7	350	315	6	16	59.3	110	M16	316	89.8
C214 C314	AS180	4-200	16	35H7	114.3H7	200	180	7	10	38.3	80	M12	175	40.8
	AS190	4-200	18	38H7	180H7	215	190	5	10	41.3	80	M12	175	41.2
	AS240	4-200	28	38H7	230H7	265	240	5	10	41.3	80	M12	175	46.4
	AS260	4-200	40	48H7	250H7	300	260	6	14	51.8	110	M16	244	66.9
	AS315	4-160	40	55H7	300H7	350	315	6	16	59.3	110	M16	316	89.8
	AS450	4-125	30	55H7	350H7	400	450	6	16	59.3	140	M16	343	97.5
C216 C316	AS260	4-200	40	48H7	250H7	300	260	6	14	51.8	110	M16	234	90.9
	AS315	4-160	40	55H7	300H7	350	315	6	16	59.3	110	M16	298	109.4
	AS450	4-125	30	55H7	350H7	400	450	6	16	59.3	140	M16	325	117.1



### 7.3 C series dimensions of AE input shaft

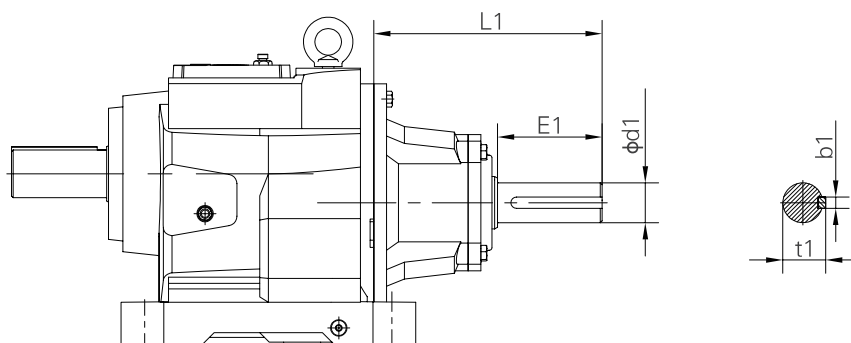

Size	Input Shaft	Range of Power	Range of Ratio	d1	E1	L1	b1	t1	Weight (kg)
C203 C303	AE2	0.12-0.75kW	4-90	19k6	40	117	6	21.5	2.5
C204 C304	AE2	0.12-0.75kW	4-125	19k6	40	119	6	21.5	3.4
	AE3	1.1-4kW	4-35.5	28k6	60	175	8	31	6.1
C205 C305	AE2	0.12-0.75kW	4.5-140	19k6	40	119	6	21.5	3.4
	AE3	1.1-4kW	4.5-56	28k6	60	175	8	31	6.1
C206 C306	AE2	0.12-0.75kW	4.5-160	19k6	40	119	6	21.5	3.4
	AE3	1.1-4kW	4.5-71	28k6	60	175	8	31	6.1
C207 C307	AE2	0.12-0.75kW	4-180	19k6	40	111	6	21.5	4.9
	AE3	1.1-4kW	4-90	28k6	60	165	8	31	7.5
	AE4	5.5-7.5kW	4-18	38k6	80	211	10	41	10.5
C208 C308	AE2	0.12-0.75kW	20-200	19k6	40	108	6	21.5	7.2
	AE3	1.1-4kW	4.5-160	28k6	60	155	8	31	10.2
	AE4	5.5-11kW	4.5-45	38k6	80	204	10	41	13.1
	AE5	15-22kW	4.5-18	42k6	110	266	12	45	23.3
C209 C309	AE3	1.1-4kW	4-224	28k6	60	156	8	31	10.2
	AE4	5.5-11kW	4-71	38k6	80	203	10	41	13.1
	AE5	15-22kW	4-40	42k6	110	265	12	45	23.3
	AE6	30-45KW	4-16	48k6	110	309	14	51.5	40.9
C210 C310	AE3	1.1-4kW	4-224	28k6	60	146	8	31	17.6
	AE4	5.5-11kW	4-100	38k6	80	190	10	41	21.9
	AE5	15-22kW	4-56	42k6	110	252	12	45	29.2
	AE6	30-45KW	4-28	48k6	110	309	14	51.5	45.5
C212 C312	AE3	1.1-4kW	4.5-280	28k6	60	146	8	31	17.6
	AE4	5.5-11kW	4.5-140	38k6	80	190	10	41	21.9
	AE5	15-22kW	4.5-71	42k6	110	252	12	45	29.2
	AE6	30-45KW	4.5-40	48k6	110	309	14	51.5	45.5
C213 C313	AE4	5.5-11kW	4-125	38k6	80	176	10	41	34.6
	AE5	15-22kW	4-100	42k6	110	238	12	45	43.8
	AE6	30-45KW	4-50	48k6	110	298	14	51.5	57.9
	AE7	55-90KW	4-20	55m6	110	297	16	59	64.6
	AE8	110-132KW	4-11.2	70m6	140	377	20	74.5	87.8
C214 C314	AE4	5.5-11kW	4-200	38k6	80	176	10	41	34.6
	AE5	15-22kW	4-160	42k6	110	238	12	45	43.8
	AE6	30-45KW	4-80	48k6	110	298	14	51.5	57.9
	AE7	55-90KW	4-45	55m6	110	297	16	59	64.6
	AE8	110-200KW	4-18	70m6	140	377	20	74.5	87.8
C216 C316	AE5	15-22KW	18-224	42k6	110	228	12	45	67.8
	AE6	30-45KW	4.5-112	48k6	110	280	14	51.5	77.5
	AE7	55-90KW	4.5-63	55m6	110	279	16	59	81.1
	AE8	110-200KW	4.5-31.5	70m6	140	361	20	74.5	104.8

## 8 Combi-type Dimensions

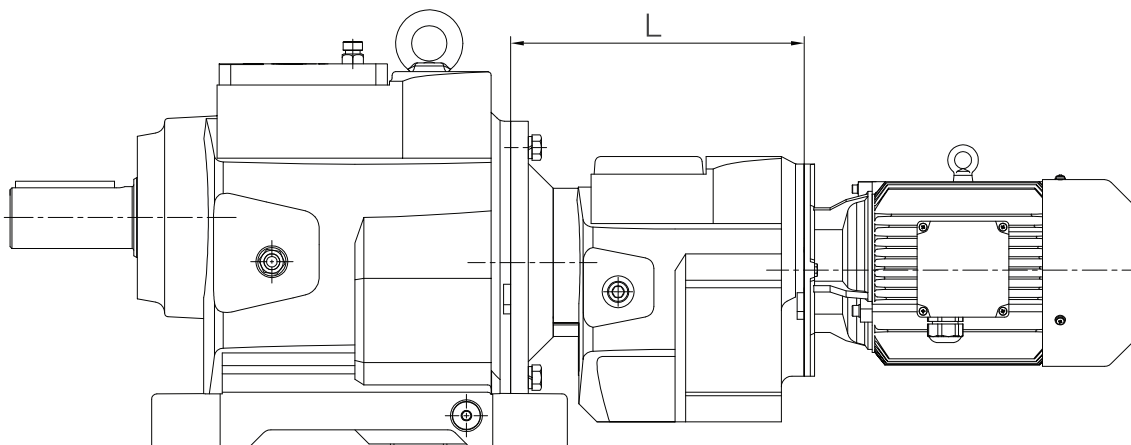

Type	C203/C201 C203/C301 C303/C201 C303/C301	C204/C203 C204/C303 C304/C203 C304/C303	C205/C203 C205/C303 C305/C203 C305/C303	C206/C203 C206/C303 C306/C203 C306/C303	C207/C203 C207/C303 C307/C203 C307/C303	C208/C205 C208/C305 C308/C205 C308/C305	C209/C205 C209/C305 C309/C205 C309/C305
L	134	170	170	170	170	182	182
Range of Motor Power (kW)	0.12-0.37	0.12-0.55	0.12-1.1	0.12-1.1	0.12-1.5	0.12-3	0.12-4
Type	C210/C207 C210/C307 C310/C207 C310/C307	C213/C207 C213/C307 C313/C207 C313/C307	C314/C207 C314/C307	C214/C208 C214/C308	C316/C209 C316/C309	C216/C210 C216/C310	
L	226	226	226	264	321	361	
Range of Motor Power (kW)	0.12-7.5	0.12-15	0.12-15	0.55-22	0.55-18.5	1.5-37	

## 9 Oil compensating tank (code 6)

Oil compensating tank for vertical mounting positions D2 of C...H/C...F/C...S.

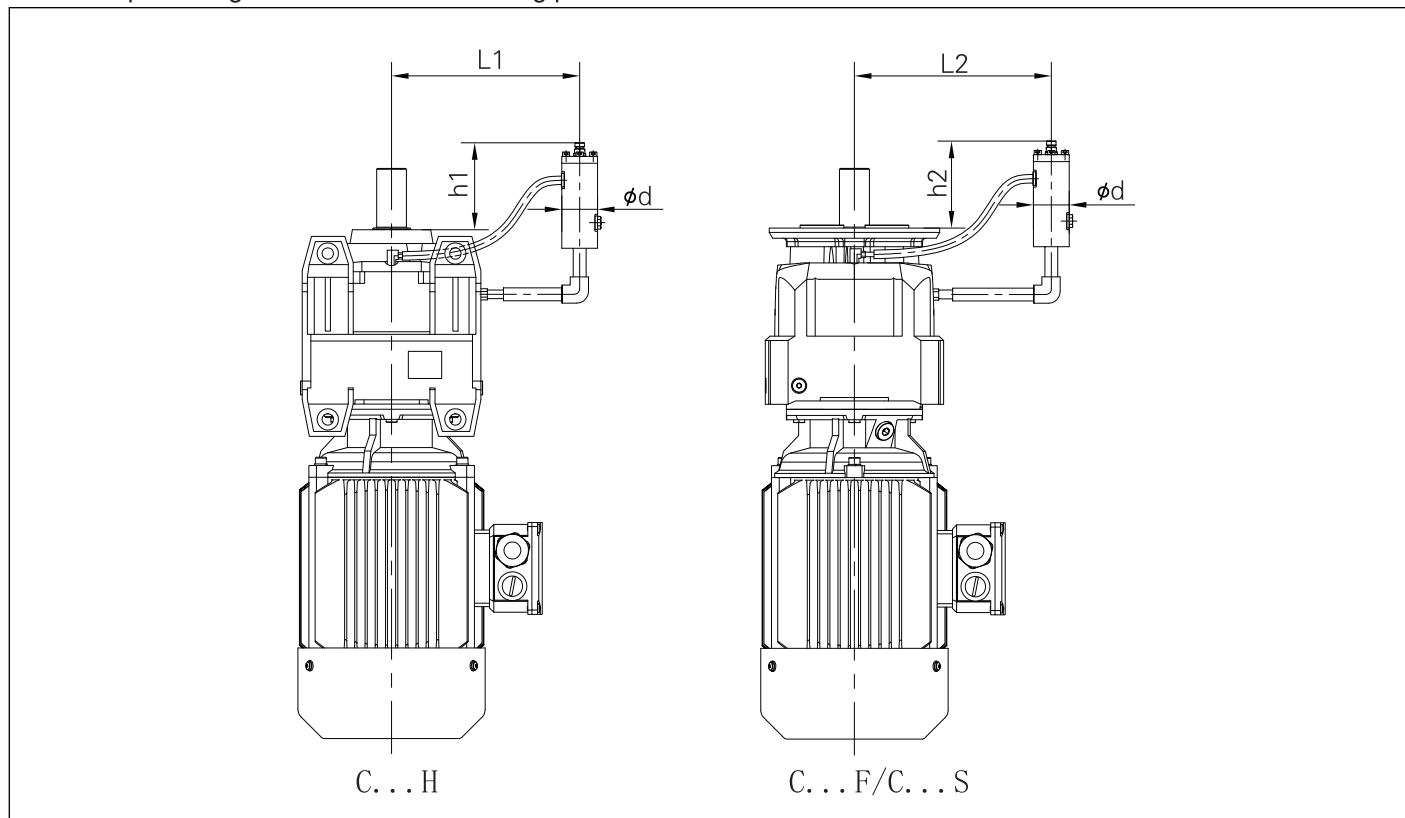

Size	L1	L2	h1	h2	d
C203 C303	150	150	80	70	42
C204 C304	160	160	80	80	42
C205 C305	160	160	80	80	42
C206 C306	180	180	75	75	42
C207 C307	225	225	150	150	80
C208 C308	250	250	130	130	80
C209 C309	330	330	120	120	80
C210 C310	370	370	160	160	120
C212 C312	380	380	170	170	120
C213 C313	390	390	160	160	120
C214 C314	440	440	130	130	120
C216 C316	470	470	140	140	120

Note: In case of an upward output shaft ,normal lubrication system would fail to feed the overhead rolling bearings, To ensure an adequate supply of lubricants, the oil level has to be increased accordingly. As shown above (D2) ,an oil compensating tank with breather is attached for this purpose.

## 10 oil

Mounting position Size	D1	D2	D3	D4	D5	D6
C200H C300H	0.2	0.2	0.2	0.3	0.2	0.2
C201H C301H	0.4	0.4	0.4	0.5	0.4	0.4
C203H C303H	0.4	1	1.1	1.2	0.9	1.1
C204H C304H	0.8	1.7	1.6	1.8	1.6	1.6
C205H C305H	0.9	1.9	1.8	2.1	1.8	1.8
C206H C306H	1.3	2.8	3.1	3.5	2	2.2
C207H C307H	1.4	4.1	3.8	4.9	2.7	4.1
C208H C308H	2.6	7.1	7.5	8.1	6.6	7.2
C209H C309H	4.9	12.1	12.1	13.8	11.7	12.5
C210H C310H	6.5	16.8	17.4	19.7	13.7	17.1
C212H C312H	7.8	20.2	20.9	23.6	16.4	20.5
C213H C313H	11	29	30.5	32.5	26	26
C214H C314H	16	47.5	49	53	40.5	42
C216H C316H	28	84	80	90	68	71

Mounting position Size	D1/D3 D5/D6	D2	D4
C200F/C200S C300F/C300S	0.2	0.2	0.3
C201F/C201S C301F/C301S	0.4	0.4	0.5
C203F/C203S C303F/C303S	0.5	1	1.2
C204F/C204S C304F/C304S	0.8	1.7	1.8
C205F/C205S C305F/C305S	0.9	1.9	1.9
C206F/C206S C306F/C306S	1.4	2.9	3.3
C207F/C207S C307F/C307S	1.4	3.9	4.3
C208F/C208S C308F/C308S	2.7	7.1	7.9
C209F/C209S C309F/C309S	5.4	12.2	14
C210F/C210S C310F/C310S	6.8	16.4	19.7
C212F/C212S C312F/C312S	8.2	19.7	23.6
C213F/C213S C313F/C313S	10.5	28	33
C214F/C214S C314F/C314S	17	48	53
C216F/C216S C316F/C316S	28	84	90

## 11 Motor Rainproof Cover Dimensions

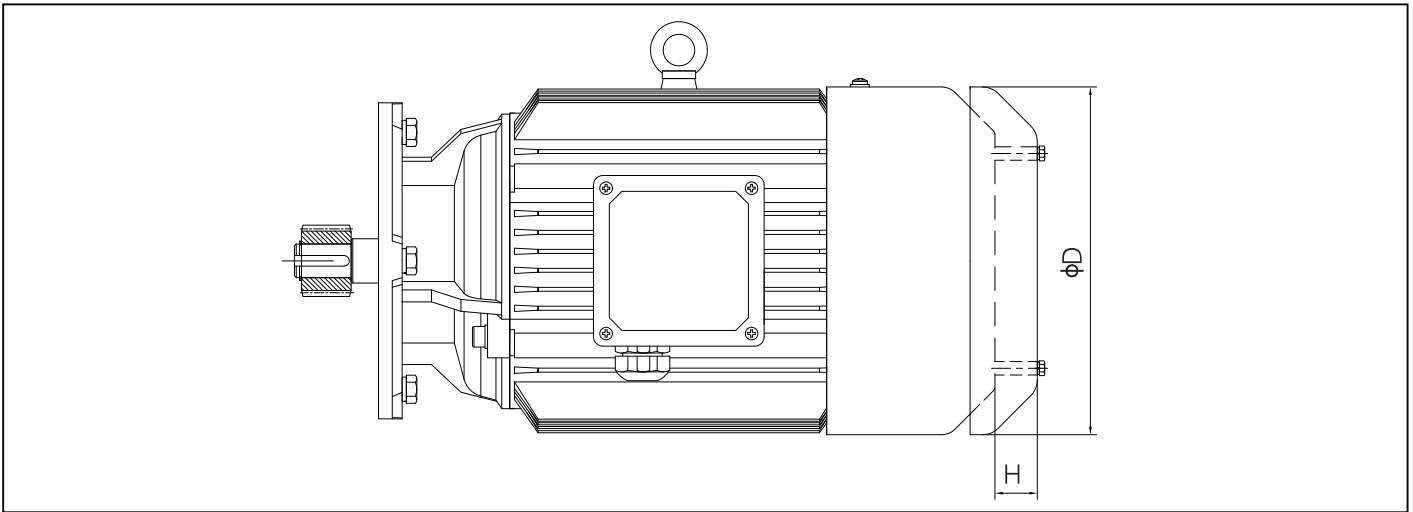

Frame Size	H63	H71	H80	H90	H100	H112	H132	H160	H180	H200	H225	H250	H280
D	124	139	159	176	199	220	259	314	356	398	446	485	547
H	20	25	25	30	35	35	40	55	60	65	70	75	80

## 12 Permissible Radial Force

### 12.1 Radial force on input shaft ( $Fr1$ ) (N)

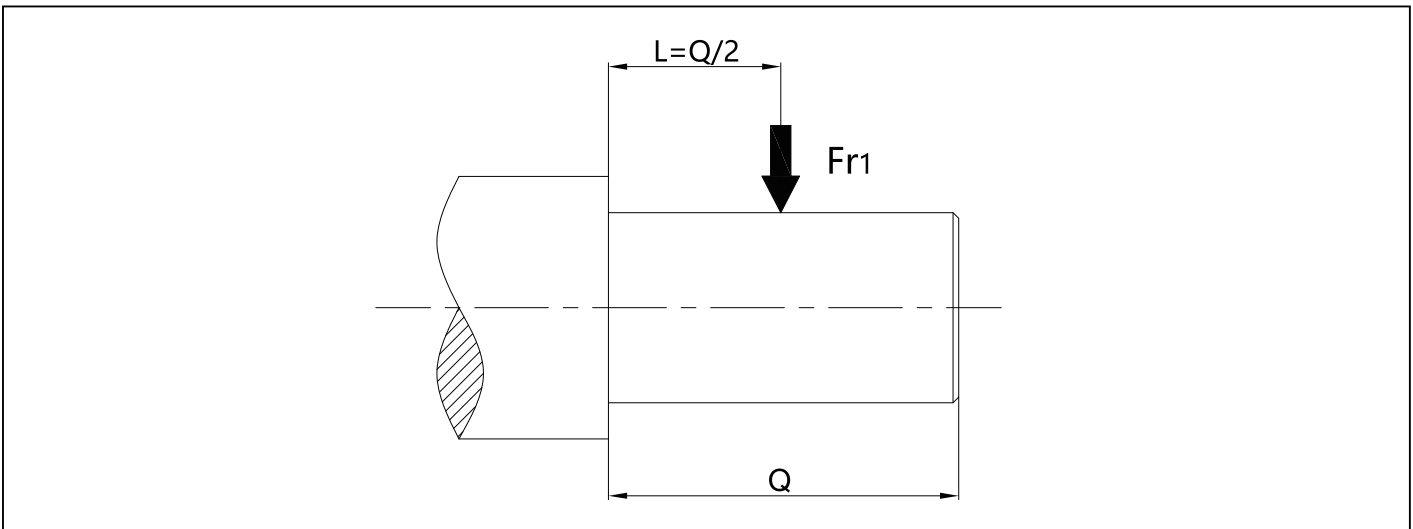

	Fr1 (N)													
	C200 C300	C201 C301	C203 C303	C204 C304	C205 C305	C206 C306	C207 C307	C208 C308	C209 C309	C210 C310	C212 C312	C213 C313	C214 C314	C216 C316
AE2	/	/	803	803	803	803	803	803	/	/	/	/	/	/
AE3	/	/	/	1504	1504	1504	1504	1504	1504	1504	1504	/	/	/
AE4	/	/	/	/	/	/	2188	2188	2188	2188	2188	2188	2188	2188
AE5	/	/	/	/	/	/	/	4207	4207	4207	4207	4207	4207	4207
AE6	/	/	/	/	/	/	/	/	5664	5664	5664	5664	5664	5664
AE7	/	/	/	/	/	/	/	/	/	/	/	9957	9957	9957
AE8	/	/	/	/	/	/	/	/	/	/	/	12546	12546	12546

## 12.2 Radial force on output shaft (Fr2) (N)

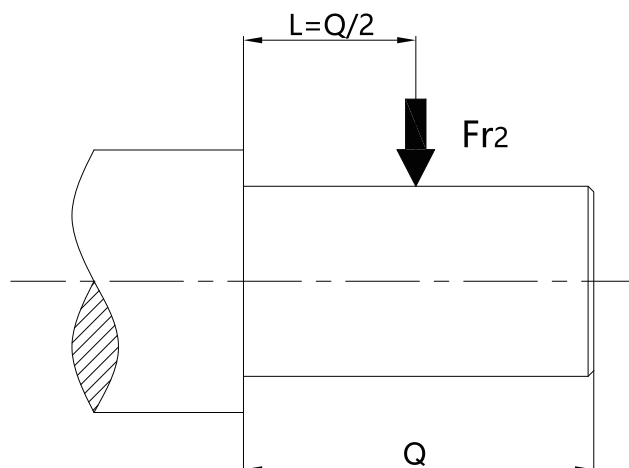

n <sub>2N</sub> (r/min)	Fr <sub>2</sub> (N)													
	C200 C300	C201 C301	C203 C303	C204 C304	C205 C305	C206 C306	C207 C307	C208 C308	C209 C309	C210 C310	C212 C312	C213 C313	C214 C314	C216 C316
355~500	210	350	/	/	/	/	/	/	/	/	/	/	/	/
250~355	246	410	684	2052	3102	4689	6096	8082	8865	10170	17770	31050	44370	/
224~250	256	427	711	2223	3344	5031	6540	8505	9450	11160	18989	32310	47800	/
200~224	324	540	900	2358	3505	5211	6774	8802	9810	11520	19718	33750	52560	/
180~224	557	929	1548	2448	3584	5247	6821	9180	10170	12420	20879	35100	48735	/
160~180	557	929	1548	2502	3663	5364	6973	9450	10710	11995	17262	24840	44910	67575
125~160	590	983	1638	2601	3859	5724	5841	9720	10890	11160	17674	27990	51600	74250
112~125	586	977	1629	2772	4073	5985	6066	10260	11430	12420	19695	31230	55710	79830
100~112	609	1015	1692	2840	4174	6134	6206	10490	11700	12960	20492	32400	57060	82125
90~100	651	1085	1809	2907	4273	6282	6651	10890	12240	13860	21915	34650	56430	91215
80~90	774	1291	2151	3033	4433	6480	6858	11340	12600	14400	22337	34650	60300	98010
71~80	833	1388	2313	3177	4537	6480	7182	11700	12960	14740	24022	39150	60300	100260
63~71	833	1388	2313	3258	4585	6453	7425	11970	13320	15570	24689	39150	58140	108000
56~63	1251	2084	3474	3543	4936	6876	9090	12510	14318	17280	27718	44460	58140	108000
45~56	1225	2041	3402	3645	5075	7065	9009	12510	14136	18090	29678	48690	56430	108000
40~45	1335	2225	3708	4221	5461	7065	8928	14400	16272	19395	30531	48060	56430	108000
35.5~40	1471	2452	4086	4167	5314	6777	8928	15120	16740	20700	31541	48060	56430	108000
31.5~35.5	1575	2624	4374	4437	5351	6453	8928	15210	17820	22050	32553	48060	56430	108000
28~31.5	1604	2673	4455	4635	5469	6453	8928	15210	17820	22950	33211	48060	56430	108000
25~28	1604	2673	4455	4815	5574	6453	8928	12150	17820	23940	33920	48060	56430	108000
22.4~25	1604	2673	4455	4878	5611	6453	8928	13680	17820	25200	34801	48060	56430	108000
≤22.4	1604	2673	4455	4878	5611	6453	8928	14220	17820	26280	35539	48060	56430	108000

### 13 Shaft End Centre Hole

Type C screw central hole in shaft end

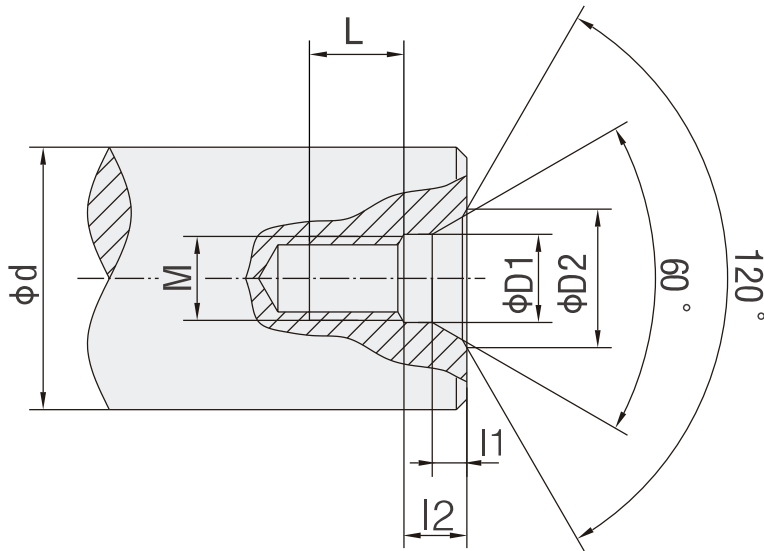

d	M	L	12	11	D1	D2
$7 < d \leq 10$	M3	10	2.6	1.8	3.2	5.8
$10 < d \leq 13$	M4	10	3.2	2.1	4.3	7.4
$13 < d \leq 16$	M5	10	4	2.4	5.3	8.8
$16 < d \leq 21$	M6	12	5	2.8	6.4	10.5
$21 < d \leq 24$	M8	12	6	3.3	8.4	13.2
$24 < d \leq 30$	M10	15	7.5	3.8	10.5	16.3
$30 < d \leq 38$	M12	20	9.5	4.4	13	19.8
$38 < d \leq 50$	M16	25	12	5.2	17	25.3
$50 < d \leq 85$	M20	30	15	6.4	21	31.3
$85 < d \leq 130$	M24	35	18	8	25	38
$130 < d \leq 225$	M30	45	18	11	31	48

## 14 Dimension of Parallel Key and Keyway

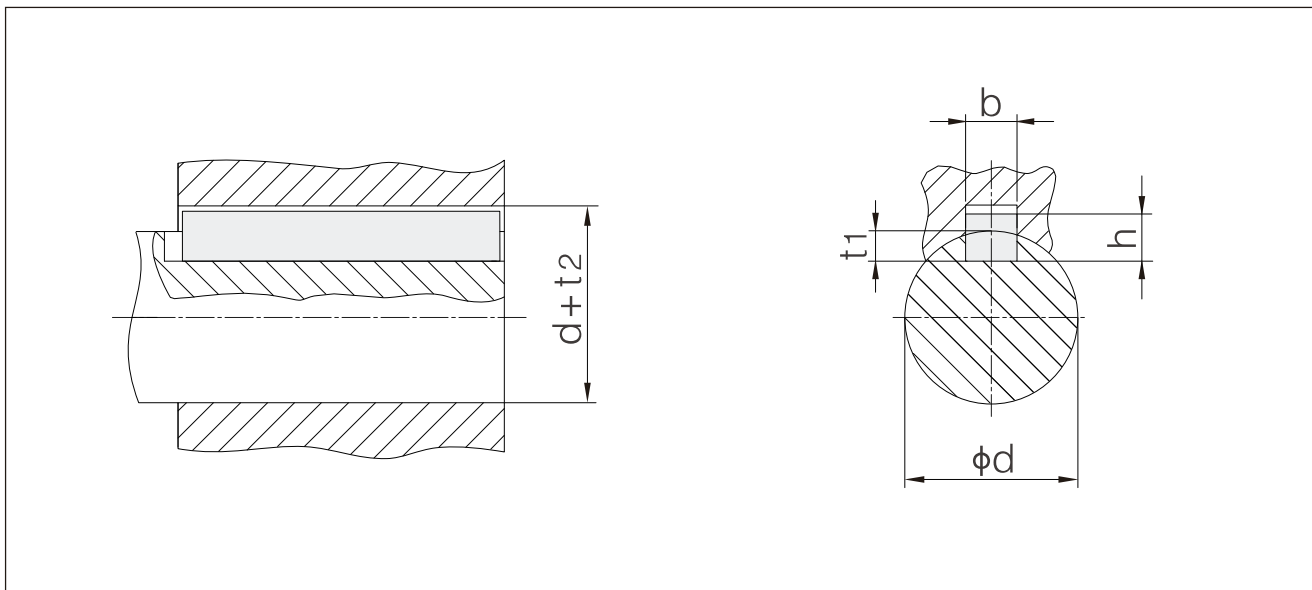

d	b	h	t1	d+t2
8 < d ≤ 10	3	3	1.8	d+1.4
10 < d ≤ 12	4	4	2.5	d+1.8
12 < d ≤ 17	5	5	3	d+2.3
17 < d ≤ 22	6	6	3.5	d+2.8
22 < d ≤ 30	8	7	4	d+3.3
30 < d ≤ 38	10	8	5	d+3.3
38 < d ≤ 44	12	8	5	d+3.3
44 < d ≤ 50	14	9	5.5	d+3.8
50 < d ≤ 58	16	10	6	d+4.3
58 < d ≤ 65	18	11	7	d+4.4
65 < d ≤ 75	20	12	7.5	d+4.9
75 < d ≤ 85	22	14	9	d+5.4
85 < d ≤ 95	25	14	9	d+5.4
95 < d ≤ 110	28	16	10	d+6.4
110 < d ≤ 130	32	18	11	d+7.4
130 < d ≤ 150	36	20	12	d+8.4
150 < d ≤ 170	40	22	13	d+9.4
170 < d ≤ 200	45	25	15	d+10.4
200 < d ≤ 230	50	28	17	d+11.4
230 < d ≤ 260	56	32	20	d+12.4





★ Manufacturing Base    ▲ Assembly Company    ▣ Sales Company    ● Office    ■ Dealer

**BonengTransmission(India)Pvt.Ltd**

402, 4th floor,8, Deepshikha Building,  
Rajendra Place, New Delhi-110008  
E-mail: india@boneng.com  
TEL: +91-11-45076293

**Mumbai Office**

No.603,Bhumiraj Costa Rica Commercial  
Building,Plot1&2,Palm Beach Road,Sector18,  
Sanpada,Navi Mumbai 400705 India  
TEL: +91-22-2781-3385  
FAX: +91-22-2781-3386

**BonengTransmission(USA)LLC.**

1670 ENTERPRISE PARKWAY,  
TWINSBURG,OH 44087  
E-mail: america@boneng.com  
TEL: 1-330-425-1516  
FAX: 1-330-425-1519

Along with the technology advancedet.,the product of the manual of Boneng will be changed,please forgive.

**BONENG**

**BONENG TRANSMISSION (SUZHOU) CO.,LTD**

100#, Ruyuan Rd.,Xiangcheng District,Suzhou,China

[www.boneng.com](http://www.boneng.com)