

YW系列电力液压鼓式制动器

YW Series Electro-hydraulic Drum Brakes

应用：电力液压鼓式制动器，广泛应用于各种起重运输、港口装卸、冶金设备、矿山机械及工程机械中各种机构的减速和停车(维持)制动。

Application:

Electro-hydraulic drum brakes can be extensively used for various mechanism deceleration and stop/braking of various belt transport, port handling, hoisting, metallurgical, mining and building machinery.

符合标准

■ YW、YWB系列制动器连接尺寸和技术要求符合JB/T6406-2006标准，制动力矩参数符合DIN15435标准；YW系列配套符合JB/T10603-2006标准的YTD系列推动器；YWB系列配套符合DIN15430标准的Ed系列推动器；本系列适用于新设计、新主机配套选用。

■ YWZ5、YWZE系列制动器连接尺寸和制动力矩参数符合GB6333-86标准，技术要求符合JB/T6406-2006标准；YWZ5系列配套符合JB/T10603-2006标准的YTD系列推动器；YWZE系列配套符合DIN15430标准的Ed系列推动器。

■ YWZ6、YWZF系列制动器连接尺寸和制动力矩参数符合JB/ZQ4388-86标准，技术要求符合JB/T6406-2006标准；YWZ6系列配套符合JB/T10603-2006标准的YTD系列推动器；YWZF配套符合DIN15430标准的Ed系列推动器；本系列适用于取代原YWZ、JCZ、JWZ及TJ2等系列老产品。

■ YWZ2、YWZB系列制动器连接尺寸和制动力矩参数符合JB/ZQ4388-86标准，技术要求符合JB/T6406-2006标准；YWZ2系列配套推动器为MYT2系列推动器，YWZB系列配套符合JB/T10603-2006标准的YTD系列推动器。本系列适用于取代原YWZ、JCZ、JWZ及TJ2等系列老产品。

■ YWZ4、YWZD系列制动器连接尺寸和制动力矩参数符合GB6333-86标准，技术要求符合JB/T6406-2006标准；YWZ4系列配套符合JB/T10603-2006标准的YTD系列推动器；YWZD系列配套符合DIN15430标准的Ed系列推动器；本系列适用于取代原YWZ3和YWZ□等系列老产品。

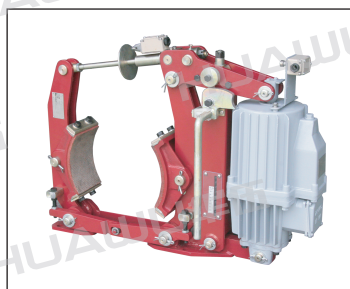

YW.YWB.YWZ5.YWZE.YWZ6.YWZF系列 Series

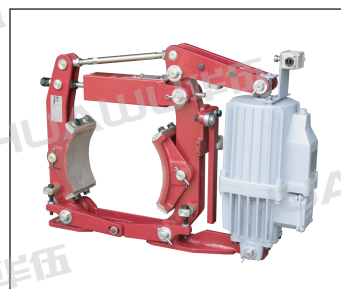

YWZ2.YWZ4.YWZB.YWZD系列 Series

Standards compliant:

■ The dimensions and technology requirements of YW, YWB series brakes comply with JB/T6406-2006 standard, braking torque parameters comply with DIN15435 standard;
YW series brakes are equipped with YTD series thrusters which comply with JB/T10603-2006 standard.
YWB series brakes are equipped with YTD series thrusters which comply with DIN15430 standard.
This series brakes is mainly used for new design and new main machines.

■ The dimensions and braking torque parameters of YWZ5, YWZE series brakes comply with GB6333-86 standard, technology requirements comply with JB/T6406-2006 standard;
YWZ5 series brakes are equipped with YTD series thrusters which comply with JB/T10603-2006 standard.
YWZE series brakes are equipped with Ed series thrusters which comply with DIN15430 standard.

■ The dimensions and braking torque parameters of YWZ6, YWZF series brakes comply with JB/ZQ4388-86 standard, technology requirements comply with JB/T6406-2006 standard;
YWZ6 series brakes are equipped with YTD series thrusters which comply with JB/T10603-2006 standard.
YWZF series brakes are equipped with Ed series thrusters which comply with DIN15430 standard. This series brakes is mainly used for taking replace of old products of YWZ, JCZ, JWZ and TJ2 series.

■ The dimensions and braking torque parameters of YWZ2, YWZB series brakes comply with JB/ZQ4388-86 standard, technology requirements comply with JB/T6406-2006 standard;
YWZ2 series brakes are equipped with MYT2 series thrusters.
YWZB series brakes are equipped with YTD series thrusters which comply with JB/T10603-2006 standard.
This series brakes is mainly used for taking replace of old products of YWZ, JCZ, JWZ and TJ2 series.

■ The dimensions and braking torque parameters of YWZ4, YWZD series brakes comply with GB6333-86 standard, technology requirements comply with JB/T6406-2006 standard;
YWZ4 series brakes are equipped with YTD series thrusters which comply with JB/T10603-2006 standard.
YWZD series brakes are equipped with Ed series thrusters which comply with DIN15430 standard.
This series brakes is mainly used for taking replace of old products of YWZ3 and YWZ□ series.

主要特点

- 联锁式退距均等装置(专利技术)和瓦块自动随位装置, 可始终保持两侧瓦块退距均等且无需调整, 完全避免因退距不均使一侧制动衬垫浮贴制动轮的现象。
- 主要摆动铰点均设有自润滑轴承, 传动效率高, 寿命长, 在使用过程中无需润滑。
- 制动弹簧在方管内置并设有标尺, 用户可十分方便地读出制动力矩值, 免去测量和计算的麻烦。
- 制动衬垫为卡装式整体成型结构, 更换十分方便、快捷, 备有半金属(无石棉)硬质和半硬质, 软质(无石棉)等不同材质的制动衬垫供用户选择。
- 配套的系列推动器产品, 动作灵敏、使用寿命长。

Main Design Features:

- Interlocking shoe clearance balancing device (patented technology) and shoe auto-aligning device constantly equalize the clearance of brake shoes on both sides and make adjustment unnecessary, completely avoiding brake lining one side sticking to brake wheel.
- Brake spring is arranged inside square tube and surveyor's rod is placed on one side. It is easy for customers to read braking torque value and avoid the troubles of measuring and computing.
- Brake spring is arranged inside square tube and surveyor's rod is placed on one side. It is easy for customers to read braking torque value and avoid the troubles of measuring and computing.
- Brake lining is of card whole piece shaping structure, which is easy and quick to replace. Brake lining of various materials such as half-metal (non-asbestos) hard and half-hard, soft (include asbestos) substance are available for customer to choose.
- The equipped series of thruster sare characterized by flexible action and long operating life.

Main Design Features:

- Interlocking shoe clearance balancing device (patented technology) and shoe auto-aligning device constantly equalize the clearance of brake shoes on both sides and make adjustment unnecessary, completely avoiding brake lining one side sticking to brake wheel.
- Brake spring is arranged inside square tube and surveyor's rod is placed on one side. It is easy for customers to read braking torque value and avoid the troubles of measuring and computing.
- Brake spring is arranged inside square tube and surveyor's rod is placed on one side. It is easy for customers to read braking torque value and avoid the troubles of measuring and computing.
- Brake lining is of card whole piece shaping structure, which is easy and quick to replace. Brake lining of various materials such as half-metal (non-asbestos) hard and half-hard, soft (include asbestos) substance are available for customer to choose.
- The equipped series of thruster sare characterized by flexible action and long operating life.

附加装置

- 手动释放装置
- 释放(开闸)限位开关, 可实现制动器是否正常释放的信号显示。
- YW、YWB、YWZ5、YWZE、YWZ6、YWZF、YWH等系列产品带制动衬垫磨损自动补偿装置, 可实现衬垫磨损时瓦块退距和制动力矩的无级自动补偿。
- 衬垫磨损极限限位开关, 可实现制动衬垫磨损到极限时的信号显示(注意: 应用于须带自动补偿装置的制动器)。
- 采用带下降延时阀的推动器时, 可实现制动器的延时闭合, 以满足一些特定场合的需要。

Additional option:

- Hand release lever.
- Open(Release) or close limit-switch, which indicates whether the brake is properly released or closed.
- YW, YWB, YWZ5, YWZE, YWZ6, YWZF and YWH series brakes with pad wear self-compensation device can realize the stepless self-compensation of shoe clearance and brake torque when pad worn.
- Lining-wear limit-switch, equipped which signals will shown when wear of lining reaches the limit (note: self-compensation device should be equipped in application)
- When use such thrusters that with descending delay valve, the delay close of brake can be realized, which can meet requirements in some specific occasion.

使用条件

- 环境温度: -25~+50℃。
 - 相对湿度: ≤90%。
 - 电压等级: 380~400V 50Hz 440~460V 60Hz。
 - 适应的工作制: 连续(S1)和断续(S3-60%, 操作频率<1200次/小时)工作制。
- 有特殊要求时, 在订货时协商确定。

Operating conditions

- Ambient temperature: -25~+50℃.
 - Relative humidity: ≤90%.
 - Voltages: 380~400V 50Hz 440~460V 60Hz
 - Operating duty: intermittent (S3-60%. 1200 times per hour) and continuous (S1).
- Special requirements can be discussed in order.



YW.YWB系列 Series
 电力液压鼓式制动器
 Electro-hydraulic drum brakes

08/2013

YW、YWB系列鼓式制动器技术参数及安装尺寸 Dimensions and technical data

制动器型号 Brake type	推动器型号 Thruuster type	制动力矩 Brake torque (Nm)	安装及外形尺寸 Dimensions (mm)																	重量 Weight (kg)		
			D														A		Q		L	
			D	h1	k	i	d	n	b	F	G	J	E	H	C	P	A型	B型	A型			B型
YW160-220 YWB160-220	YTD220-50 Ed220-50	80~160	160	132	130	55	14	6	65	90	150	210	145	430	80	135	440	405	80	115	455	25
YW200-220 YWB200-220	YTD220-50 Ed220-50	100~200	200	160	145	55	14	8	70	90	165	245	170	510	80	135	450	415	80	115	470	39
YW200-300 YWB200-300	YTD300-50 Ed300-50	140~280																				
YW250-220 YWB250-220	YTD220-50 Ed220-50	125~250	250	190	180	65	18	10	90	100	200	275	205	525	80	135	545	510	80	115	535	47
YW250-300 YWB250-300	YTD300-50 Ed300-50	160~315																				49
YW250-500 YWB250-500	YTD500-60 Ed500-60	250~500												590	97	152	545	485	97	157	600	61
YW315-300 YWB315-300	YTD300-50 Ed300-50	200~400	315	230	220	80	18	10	110	110	245	358	260	620	80	135	570	530	80	120	560	80
YW315-500 YWB315-500	YTD500-60 Ed500-60	315~630																				86
YW315-800 YWB315-800	YTD800-60 Ed800-60	500~1000												97	152	605	540	97	157	650	88	
YW400-500 YWB400-500	YTD500-60 Ed500-60	400~800	400	280	270	100	22	12	140	140	300	420	305	745	97	152	650	590	97	157	705	108
YW400-800 YWB400-800	YTD800-60 Ed800-60	630~1250																				110
YW400-1250 YWB400-1250	YTD1250-60 Ed1250-60	1000~2000												815	120	175	700	670	120	150	885	133
YW500-800 YWB500-800	YTD800-60 Ed800-60	800~1600	500	340	325	130	22	16	180	180	365	484	370	860	97	152	780	720	97	157	785	202
YW500-1250 YWB500-1250	YTD1250-60 Ed1250-60	1250~2500																				206
YW500-2000 YWB500-2000	YTD2000-60 Ed2000-60	2000~4000												120	175	770	740	120	150	955	208	
YW630-1250 YWB630-1250	YTD1250-60(120) Ed1250-60(120)	1600~3150	630	420	400	170	27	20	225	220	450	590	455	1015	120	220	870	840	120	150	1055	309
YW630-2000 YWB630-2000	YTD2000-60(120) Ed2000-60(120)	2500~5000																				310
YW630-3000 YWB630-3000	YTD3000-60(120) Ed3000-60(120)	3550~7100																				315
YW710-2000 YWB710-2000	YTD2000-60(120) Ed2000-60(120)	2500~5000	710	470	450	190	27	22	255	240	500	705	520	1195	120	220	985	955	120	150	1145	468
YW710-3000 YWB710-3000	YTD3000-60(120) Ed3000-60(120)	4000~8000																				470
YW800-3000 YWB800-3000	YTD3000-60(120) Ed3000-60(120)	5000~10000	800	530	520	210	27	28	280	280	570	860	620	1330	120	220	1150	1120	120	150	1290	655

注:630及以上规格制动器带WC功能时,使用短行程推动器。
 Notes: Short-stroke thruusters will be adopted for thruuster 630 or above types with WC function.



YWZ5.YWZE.YWZ6.YWZF系列 Series
电力液压鼓式制动器
Electro-hydraulic drum brakes

08/2013

YWZ5、YWZE系列鼓式制动器技术参数及安装尺寸 *Technical data and dimensions of YWZ5, YWZE series drum brakes*

制动器型号 <i>Brake type</i>	推动器型号 <i>Thruster type</i>	制动力矩 <i>Brake torque (Nm)</i>	安装及外形尺寸 <i>Dimensions(mm)</i>																	重量 <i>Weight (kg)</i>				
			D	h1	k	i	d	n	b	F	G	J	E	H	C	P	Q		A		L			
																	A型	B型	A型			B型		
YWZ5-160/22 YWZE-160/22	YTD220-50 Ed220-50	80~160	160	132	130	55	14	6	65	90	150	210	145	430	80	135	80	115	440	405	455	25		
YWZ5-200/22 YWZE-200/22	YTD220-50 Ed220-50	100~200	200	160	145	55	14	8	80	90	165	245	170	510	80	135	80	115	450	415	470	39		
YWZ5-200/30 YWZE-200/30	YTD300-50 Ed300-50	140~280																				42		
YWZ5-250/30 YWZE-250/30	YTD300-50 Ed300-50	160~315	250	190	180	65	18	10	100	100	200	275	205	525	80	135	80	115	545	510	535	49		
YWZ5-250/50 YWZE-250/50	YTD500-60 Ed500-60	250~500																				61		
YWZ5-315/30 YWZE-315/30	YTD300-50 Ed300-50	200~400	315	225	220	80	18	10	125	110	245	358	260	620	80	135	97	152	157	570	530	560	80	
YWZ5-315/50 YWZE-315/50	YTD500-60 Ed500-60	315~630																					86	
YWZ5-315/80 YWZE-315/80	YTD800-60 Ed800-60	500~1000	315	225	220	80	18	10	125	110	245	358	260	620	80	135	97	152	80	120	605	540	650	88
YWZ5-400/50 YWZE-400/50	YTD500-60 Ed500-60	400~800																						108
YWZ5-400/80 YWZE-400/80	YTD800-60 Ed800-60	630~1250	400	280	270	100	22	12	160	140	300	420	305	745	97	152	97	157	650	590	705	705	110	
YWZ5-400/125 YWZE-400/125	YTD1250-60 Ed1250-60	1000~2000																					133	
YWZ5-500/80 YWZE-500/80	YTD800-60 Ed800-60	800~1600	500	335	325	130	22	16	200	180	365	484	370	860	97	152	120	150	780	720	785	785	202	
YWZ5-500/125 YWZE-500/125	YTD1250-60 Ed1250-60	1250~2500																					206	
YWZ5-500/200 YWZE-500/200	YTD2000-60 Ed2000-60	2000~4000	500	335	325	130	22	16	200	180	365	484	370	860	120	175	120	150	770	740	955	955	208	
YWZ5-630/125 YWZE-630/125	YTD1250-60(120) Ed1250-60(120)	1600~3150																					309	
YWZ5-630/200 YWZE-630/200	YTD2000-60(120) Ed2000-60(120)	2500~5000	630	425	400	170	27	20	250	220	450	590	455	1015	120	220	120	150	870	840	1055	1055	310	
YWZ5-630/300 YWZE-630/300	YTD3000-60(120) Ed3000-60(120)	3550~7100																					315	
YWZ5-710/200 YWZE-710/200	YTD2000-60(120) Ed2000-60(120)	2500~5000	710	475	450	190	27	22	280	240	500	705	520	1195	120	220	120	150	985	955	1145	1145	468	
YWZ5-710/300 YWZE-710/300	YTD3000-60(120) Ed3000-60(120)	4000~8000																					470	
YWZ5-800/300 YWZE-800/300	YTD3000-60(120) Ed3000-60(120)	5000~10000	800	530	520	210	27	28	320	280	570	860	620	1330	120	220	120	150	1150	1120	1290	1290	655	

注: 630及以上规格制动器带WC功能时, 使用短行程推动器。 *Notes: Short-stroke thrusters will be adopted for thruster 630 or above types with WC function.*

YWZ6、YWZF系列鼓式制动器技术参数及安装尺寸 *Technical data and dimensions of YWZ6, YWZF series drum brakes*

制动器型号 <i>Brake type</i>	推动器型号 <i>Thruster type</i>	制动力矩 <i>Brake torque (Nm)</i>	安装及外形尺寸 <i>Dimensions(mm)</i>																	重量 <i>Weight (kg)</i>			
			D	h1	k	i	d	n	b	F	G	J	E	H	C	P	A		Q		L		
																	A型	B型	A型			B型	
YWZ6-200/30 YWZF-200/30	YTD300-50 Ed300-50	140~280	200	170	175	60	17	8	90	100	210	245	170	520	80	135	450	415	80	115	470	38	
YWZ6-300/30 YWZF-300/30	YTD300-50 Ed300-50	160~320	300	240	250	80	22	10	140	130	295	358	252	630	80	135	570	530	80	120	560	560	68
YWZ6-300/50 YWZF-300/50	YTD500-60 Ed500-60	315~630																					88
YWZ6-400/50 YWZF-400/50	YTD500-60 Ed500-60	400~800	400	320	325	130	22	12	180	180	350	420	305	785	97	152	655	595	97	157	715	715	108
YWZ6-400/80 YWZF-400/80	YTD800-60 Ed800-60	630~1250																					110
YWZ6-400/125 YWZF-400/125	YTD1250-60 Ed1250-60	1000~2000	400	320	325	130	22	12	180	180	350	420	305	850	120	175	700	670	120	150	890	890	120
YWZ6-500/80 YWZF-500/80	YTD800-60 Ed800-60	800~1600																					200
YWZ6-500/125 YWZF-500/125	YTD1250-60 Ed1250-60	1250~2500	500	400	380	150	22	16	200	200	405	484	370	925	120	175	770	740	120	150	955	955	208
YWZ6-500/200 YWZF-500/200	YTD2000-60 Ed2000-60	2000~4000																					208
YWZ6-600/200 YWZF-600/200	YTD2000-60(120) Ed2000-60(120)	2500~5000	600	475	475	170	26	20	240	220	500	642	460	1050	120	220	870	840	120	150	1055	1055	310
YWZ6-600/300 YWZF-600/300	YTD3000-60(120) Ed3000-60(120)	3550~7100																					315
YWZ6-700/200 YWZF-700/200	YTD2000-60(120) Ed2000-60(120)	2500~5000	700	550	540	200	34	22	280	270	575	705	520	1245	120	220	985	955	120	150	1145	1145	465
YWZ6-700/300 YWZF-700/300	YTD3000-60(120) Ed3000-60(120)	4000~8000																					470

注: 600及以上规格制动器带WC功能时, 使用短行程推动器。 *Notes: Short-stroke thrusters will be adopted for thruster 600 or above types with WC function.*



YWZ2.YWZ4.YWZB.YWZD系列 Series
 电力液压鼓式制动器
 Electro-hydraulic drum brakes

08/2013

外形及安装尺寸

Outline and installation dimensions

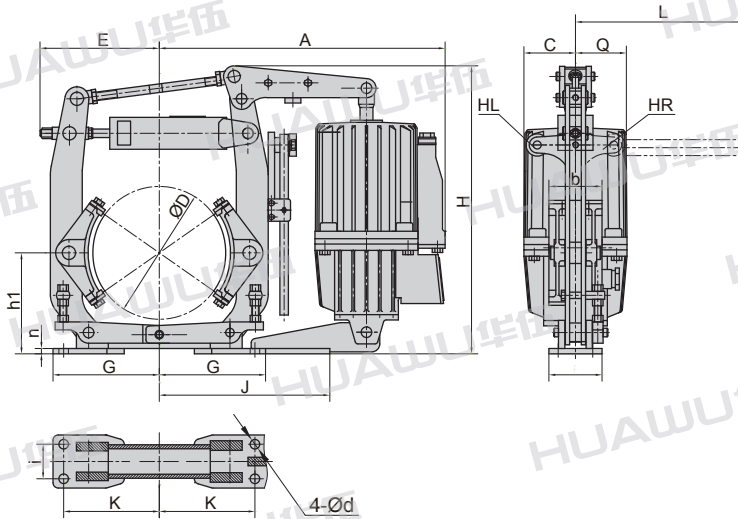

I A型安装
 Installation of I A

II A型安装
 Installation of II A

I B型安装
 Installation of I B

II B型安装
 Installation of II B

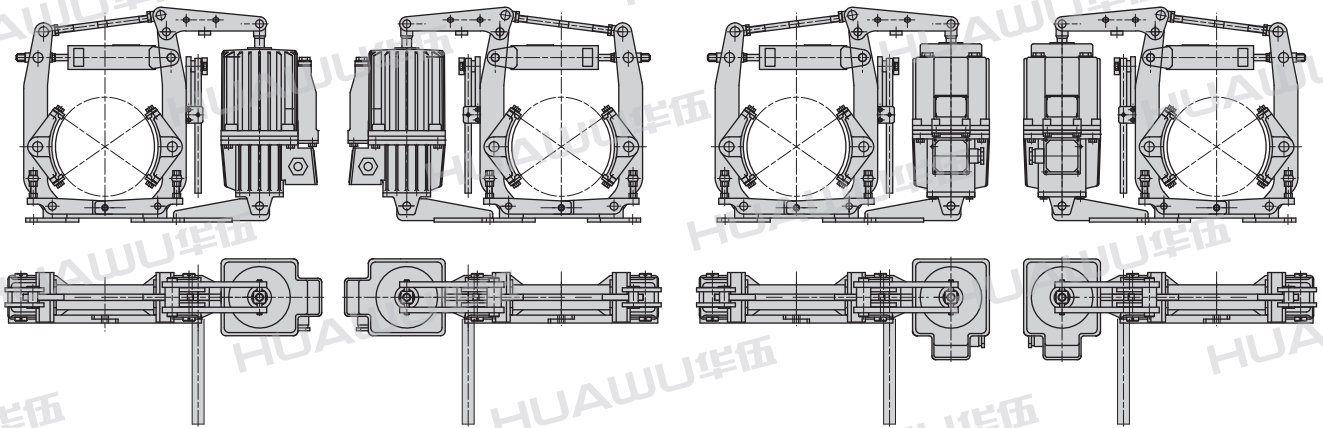

订货标记 Order Mark

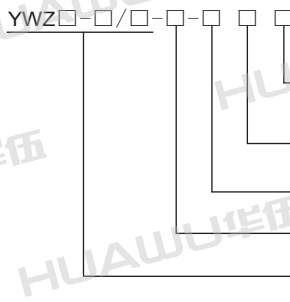

特殊要求 (可用文字说明)

Special requirement (can be specified in words)

电压等级 (380V, 50Hz时不标)

Voltage (380V, 50Hz unnecessary)

附加装置 Additional option

安装型式

产品型号 Type

- I A
- II A
- I B
- II B

CP-防腐型 Corrosion protection

RL-开闸限位开关 Release limit-switch

HL-手动释放装置 (左侧布置)

Hand release lever (left laid)

HR-手动释放装置 (右侧布置)

Hand release lever (right laid)

订货示例 Order Example

YWZ4-315/50- I A-RL.HL-440V.60Hz.CP YWZ2-300/50- I A-RL-440V.60Hz.CP YWZB-300/50- I A-RL.HL-440V.60Hz.CP
 YWZ4-315/50- I A YWZ2-300/50- I A YWZB-300/50- I A



YWZ2.YWZ4系列 Series
电力液压鼓式制动器
Electro-hydraulic drum brakes

08/2013

YWZ2系列鼓式制动器技术参数及安装尺寸 Technical data and dimensions of YWZ2 series drum brakes

制动器型号 Brake type	推动器型号 Thruster type	制动力矩 Brake torque (Nm)	安装及外形尺寸 Dimensions(mm)																重量 Weight (kg)		
			D	h1	k	i	d	n	b	F	G	J	E	H	A		Q			L	C
															A型	B型	A型	B型			
YWZ2-100/10	MYT2-10/2.5	20~40	100	100	110	40	13	8	70	70	130	175	130	335	330	300	80	110	90	80	22
YWZ2-200/25	MYT2-25/4	100~200	200	170	175	60	17	8	90	100	210	245	170	470	420	385	80	115	260	80	33
YWZ2-300/25	MYT2-25/4	160~320	300	240	250	80	22	10	140	130	295	358	275	590	530	490	80	120	260	80	65
YWZ2-300/50	MYT2-50/6	315~630												580	580	525	97	152	340	97	86
YWZ2-400/50	MYT2-50/6	500~1000	400	320	325	130	22	12	180	180	350	420	350	745	665	600	97	162	450	97	111
YWZ2-400/100	MYT2-100/6	800~1600												810	625	565	97	157			115
YWZ2-400/125	MYT2-125/6	1000~2000												810	650	620	120	150	450	120	133
YWZ2-500/125	MYT2-125/10	1250~2500	500	400	380	150	22	16	200	200	405	484	410	915	730	705	120	150	450	120	212
YWZ2-600/200	MYT2-200/12	2500~5000	600	475	475	170	27	20	240	220	500	590	455	1070	840	810	120	150	450	120	309
YWZ2-700/200	MYT2-200/12	4000~8000	700	550	540	200	34	25	280	270	575	760	550	1255	1050	1020	120	150	450	120	390
YWZ2-800/200	MYT2-200/12	5000~10000	800	600	620	240	34	28	320	310	660	860	700	1480	1190	1160	120	150	450	120	692
YWZ2-800/300	MYT2-300/12	6300~12500												1780	1085	1060	120	150			680

YWZ4系列鼓式制动器技术参数及安装尺寸 Technical data and dimensions of YWZ4 series drum brakes

制动器型号 Brake type	推动器型号 Thruster type	制动力矩 Brake torque (Nm)	安装及外形尺寸 Dimensions (mm)																重量 Weight (kg)										
			D	h1	k	i	d	n	b	F	G	J	E	H	A		Q			L	C								
															A型	B型	A型	B型											
YWZ4-160/22	YTD220-50	80~160	160	132	130	55	14	6	65	90	150	210	165	390	415	380	80	115	200	80	25								
YWZ4-200/22	YTD220-50	100~200	200	160	145	55	14	8	80	90	165	265	190	470	440	405	80	115	260	80	38								
YWZ4-200/30	YTD300-50	140~280										245									39								
YWZ4-250/30	YTD300-50	160~315	250	190	180	65	18	10	100	100	200	275	225	500	490	455	80	115	260	80	47								
YWZ4-250/50	YTD500-60	250~500												550	540	480	97	157	320	97	61								
YWZ4-300/30	YTD300-50	160~315	300	225	220	80	18	10	125	110	245	358	275	585	570	530	80	120	260	80	74								
YWZ4-300/50	YTD500-60	250~500													590		97	157	340	97	86								
YWZ4-300/80	YTD800-60	500~1000													590	97	157	340	97	88									
YWZ4-315/30	YTD300-50	160~315	315	225	220	80	18	10	125	110	245	358	275	585	570	530	80	120	260	80	74								
YWZ4-315/50	YTD500-60	250~500													590		97	157	340	97	86								
YWZ4-315/80	YTD800-60	500~1000													590	97	157	340	97	88									
YWZ4-400/50	YTD500-60	315~630	400	280	270	100	22	12	160	140	300	420	350	705	625	565	97	157	450	97	108								
YWZ4-400/80	YTD800-60	630~1250													625	565	97	157			110								
YWZ4-400/125	YTD1250-60	900~1800													350	770	610	580	120	150	120	133							
YWZ4-500/80	YTD800-60	800~1600	500	335	325	130	22	16	200	180	365	484	395	835	740	680	97	157	450	97	202								
YWZ4-500/125	YTD1250-60	1125~2250																			410	850	730	700	120	150	450	120	212
YWZ4-500/200	YTD2000-60	1600~3150																			410	850	730	700	120	150	450	120	212
YWZ4-630/125	YTD1250-120	1400~2800	630	425	400	170	27	20	250	220	450	590	455	1020	840	810	120	150	450	120	309								
YWZ4-630/200	YTD2000-120	2250~4500																			310								
YWZ4-630/300	YTD3000-120	3550~7100																			315								
YWZ4-710/200	YTD2000-120	2500~5000	710	475	450	190	27	22	280	240	500	705	565	1170	1050	1020	120	150	450	120	455								
YWZ4-710/300	YTD3000-120	4000~8000																			460								
YWZ4-800/300	YTD3000-120	6300~12500	800	530	520	210	27	28	320	280	570	860	710	1410	1085	1060	120	150	450	120	652								



YWZB.YWZD系列 Series
 电力液压鼓式制动器
 Electro-hydraulic drum brakes

08/2013

YWZB系列鼓式制动器技术参数及安装尺寸 Technical data and dimensions of YWZB series drum brakes

制动器型号 Brake type	推动器型号 Thruster type	制动力矩 Brake torque (Nm)	安装及外形尺寸 Dimensions (mm)																重量 Weight (kg)		
			D	h1	k	i	d	n	b	F	G	J	E	H	A		Q			L	C
			A型		B型		A型		B型		L		C								
YWZB-200/30	YTD300-50	100~200	200	170	175	60	17	8	90	100	210	245	170	470	420	385	80	115	260	80	33
YWZB-300/30	YTD300-50	160~320	300	240	250	80	22	10	140	130	295	358	275	590	530	490	80	120	260	80	65
YWZB-300/50	YTD500-60	315~630												580	580	525	97	152	340	97	86
YWZB-400/50	YTD500-60	500~1000	400	320	325	130	22	12	180	180	350	420	350	745	665	600	97	162	450	97	111
YWZB-400/80	YTD800-60	800~1600												810							810
YWZB-400/125	YTD1250-60	1000~2000												810	650	620	120	150	450	120	133
YWZB-500/125	YTD1250-60	1250~2500	500	400	380	150	22	16	200	200	405	484	410	915	730	705	120	145	450	120	212
YWZB-600/200	YTD2000-120	2500~5000	600	475	475	170	27	20	240	220	500	590	455	1070	840	810	120	150	450	120	309
YWZB-700/200	YTD2000-120	4000~8000	700	550	540	200	34	25	280	270	575	760	550	1255	1050	1020	120	150	450	120	375
YWZB-800/200	YTD2000-120	5000~10000	800	600	620	240	34	28	320	310	660	860	700	1480	1190	1160	120	150	450	120	672
YWZB-800/300	YTD3000-120	6300~12500												1780	1085	1060	120	145			662

YWZD系列鼓式制动器技术参数及安装尺寸 Technical data and dimensions of YWZD series drum brakes

制动器型号 Brake type	推动器型号 Thruster type	制动力矩 Brake torque (Nm)	安装及外形尺寸 Dimensions (mm)																重量 Weight (kg)		
			D	h1	k	i	d	n	b	F	G	J	E	H	A		Q			L	C
			A型		B型		A型		B型		L		C								
YWZD-160/22	Ed220-50	80~160	160	132	130	55	14	6	65	90	150	210	165	390	415	380	80	115	200	80	25
YWZD-200/22	Ed220-50	100~200	200	160	145	55	14	8	80	90	165	265	190	470	440	405	80	115	260	80	33
YWZD-200/30	Ed300-50	140~280													440						440
YWZD-250/30	Ed300-50	160~315	250	190	180	65	18	10	100	100	200	275	225	500	490	455	80	115	260	80	47
YWZD-250/50	Ed500-60	250~500												550	540	480	97	157	320	97	61
YWZD-300/30	Ed300-50	160~315	300	225	220	80	18	10	125	110	245	358	275	585	570	530	80	120	260	80	74
YWZD-300/50	Ed500-60	250~500													590						590
YWZD-300/80	Ed800-60	500~1000													590	590	97	157	340	97	88
YWZD-315/30	Ed300-50	160~315	315	225	220	80	18	10	125	110	245	358	275	585	570	530	80	120	260	80	74
YWZD-315/50	Ed500-60	250~500													590						590
YWZD-315/80	Ed800-60	500~1000													590	590	97	157	340	97	88
YWZD-400/50	Ed500-60	315~630	400	280	270	100	22	12	160	140	300	420	350	705	625	565	97	157	450	97	108
YWZD-400/80	Ed800-60	630~1250																			625
YWZD-400/125	Ed1250-60	900~1800													625	565	97	157	450	97	133
YWZD-500/80	Ed800-60	800~1600	500	335	325	130	22	16	200	180	365	484	395	835	740	680	97	157	450	97	202
YWZD-500/125	Ed1250-60	1125~2250																			740
YWZD-500/200	Ed2000-60	1600~3150													740	680	97	157	450	97	212
YWZD-630/125	Ed1250-120	1400~2800	630	425	400	170	27	20	250	220	450	590	455	1020	840	800	120	150	450	120	309
YWZD-630/200	Ed2000-120	2250~4500																			840
YWZD-630/300	Ed3000-120	3550~7100													840	800	120	150	450	120	315
YWZD-710/200	Ed2000-120	2500~5000	710	475	450	190	27	22	280	240	500	705	565	1170	1050	1020	120	150	450	120	455
YWZD-710/300	Ed3000-120	4000~8000	800	530	520	210	27	28	320	280	570	806	710	1410	1085	1066	120	145	450	120	460
YWZD-800/300	Ed3000-120	6300~12500																			1085