

BONENG

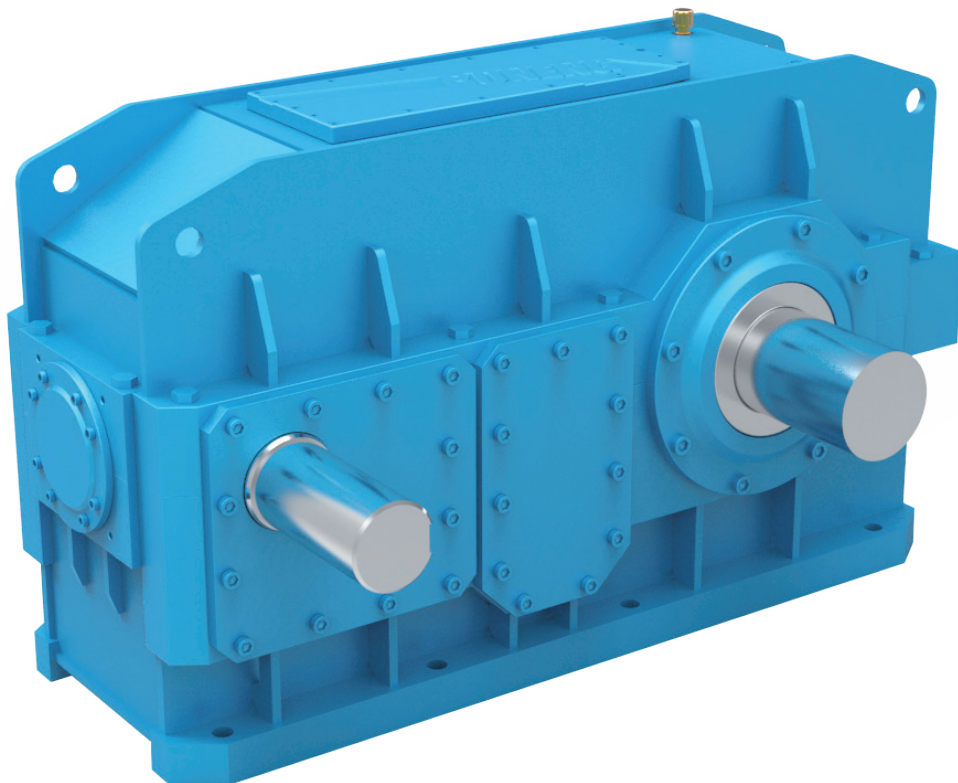

**H Helical Gearbox & B
Bevel-helical Gearbox Sizes 19-26**

Modified date 06/2021
Selection Sample C05.0029-EN

Boneng Transmission



*Boneng Transmission More products: drive / motor / gearmotor / gear box
Please browse: www.boneng.com*

BONENG H Helical Gearbox & B Bevel-helical Gearbox



On the basis of summarizing gearbox design and manufacturing experiences in the past twenty years, analyzing and absorbing advanced technology of international heavy duty gearbox production, Boneng transmission makes innovative development, pushing forward the new type H&B heavy duty gearbox to better satisfy customer requirements.

Compared with internationally advanced gearbox and the original H&B industrial gearbox of Boneng, the new type H&B heavy duty gearbox have the following characteristics:

- ◆ Unique modular design, general applications of components are maximized, which is convenient for international production. Storage quantity is small, supplement circle is short.
- ◆ Unique modular design, allocation exchange degree of functional attachments flexibly satisfy various kinds of required structures, arrangement form and different working situations of customer equipment.
- ◆ Transmission shaft is in line layout, under the same volume, transmission central distance is larger, bearing capacity is larger.
- ◆ Wheel pair meshing contact ratio increases, transmission is more stable, noise is lower.
- ◆ The appearance design shows world-wide product design idea of Boneng Transmission, it owns intellectual property rights.
- ◆ Frame type load-carrying structure design, the whole structure is stronger, footing is more fastened.
- ◆ Improved cooling fan and cooling coil design can effectively reduce the temperature during gearbox running.
- ◆ Output shaft sealing applies double oil sealing, the sealing is more reliable, the applications are wider.

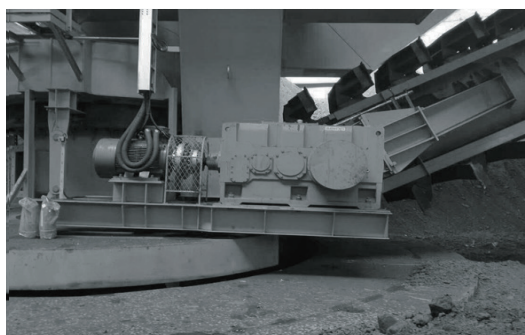
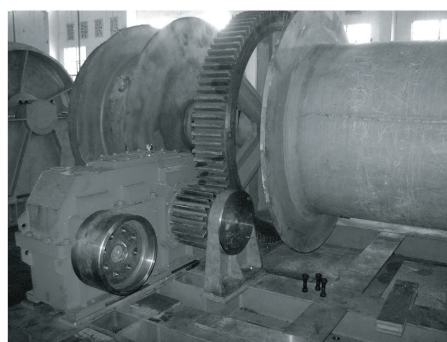
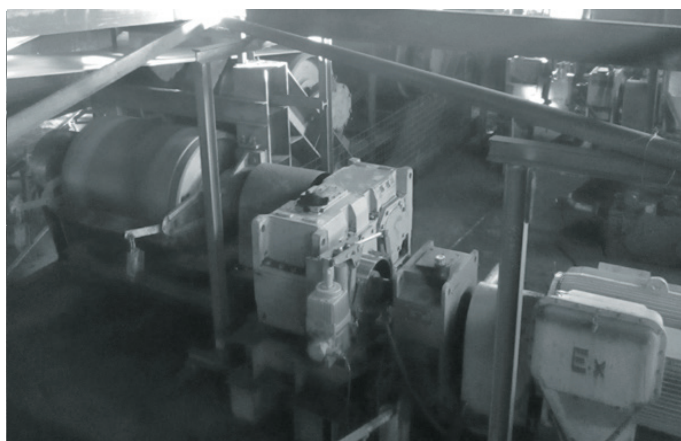
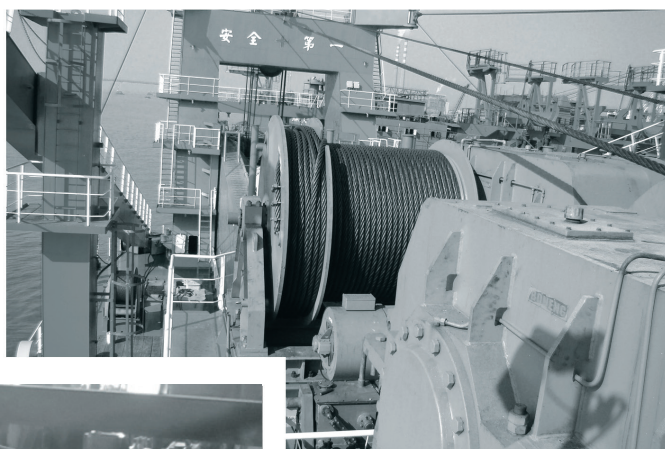

For coal, electric power, petroleum, metallurgy, cement, shipping, port, hoisting and conveying industries, the high-quality and long lifespan new type gearbox of Boneng Transmission can satisfy your requirements.

Note:

- ◆ The structure scheme, appearance diagram and other attached diagrams in sample are examples, there is no strict proportion requirement. (The unmarked dimension units are mm).
- ◆ The marked weight is average value, it has no constraint force.

You must conform to the following instructions:

- ◆ To prevent accidents, all the rotation parts are added with protective covers according to the safety regulations of the nation and region.
- ◆ Before debugging, you should carefully read instruction book.
- ◆ Gearbox is on running—permission status when delivered, you should add lubrication oil before putting it into running.
- ◆ The marked oil quantity in sample is only reference value, actual oil filling quantity should be the same with the mark on oil immersion lens.
- ◆ Lubrication oil viscosity should be selected according to working situation and application environment temperature of gearmotor.
- ◆ You can only apply lubrication oil of internationally famous brand.

Product Function Mark



Oil glass



Breather



Oil filler



Oil drain

Contents

▶-----	Structure scheme	01
▶-----	Mounting mode	02
▶-----	Type designation	02
▶-----	Selection	03
▶-----	Service factors	05
▶-----	Key to symbols	07
▶-----	Selection example	08
▶-----	Transmission capacity table	09
▶-----	Rated thermal capacity table	19
▶-----	Permissible additional radial force on output shaft	23
▶-----	Shaft assemblies	25
▶-----	Outline dimension	27
▶-----	Accessory	32
▶-----	Shaft end centre hole	36
▶-----	Dimension of parallel key and keyway	37

1 Structure scheme

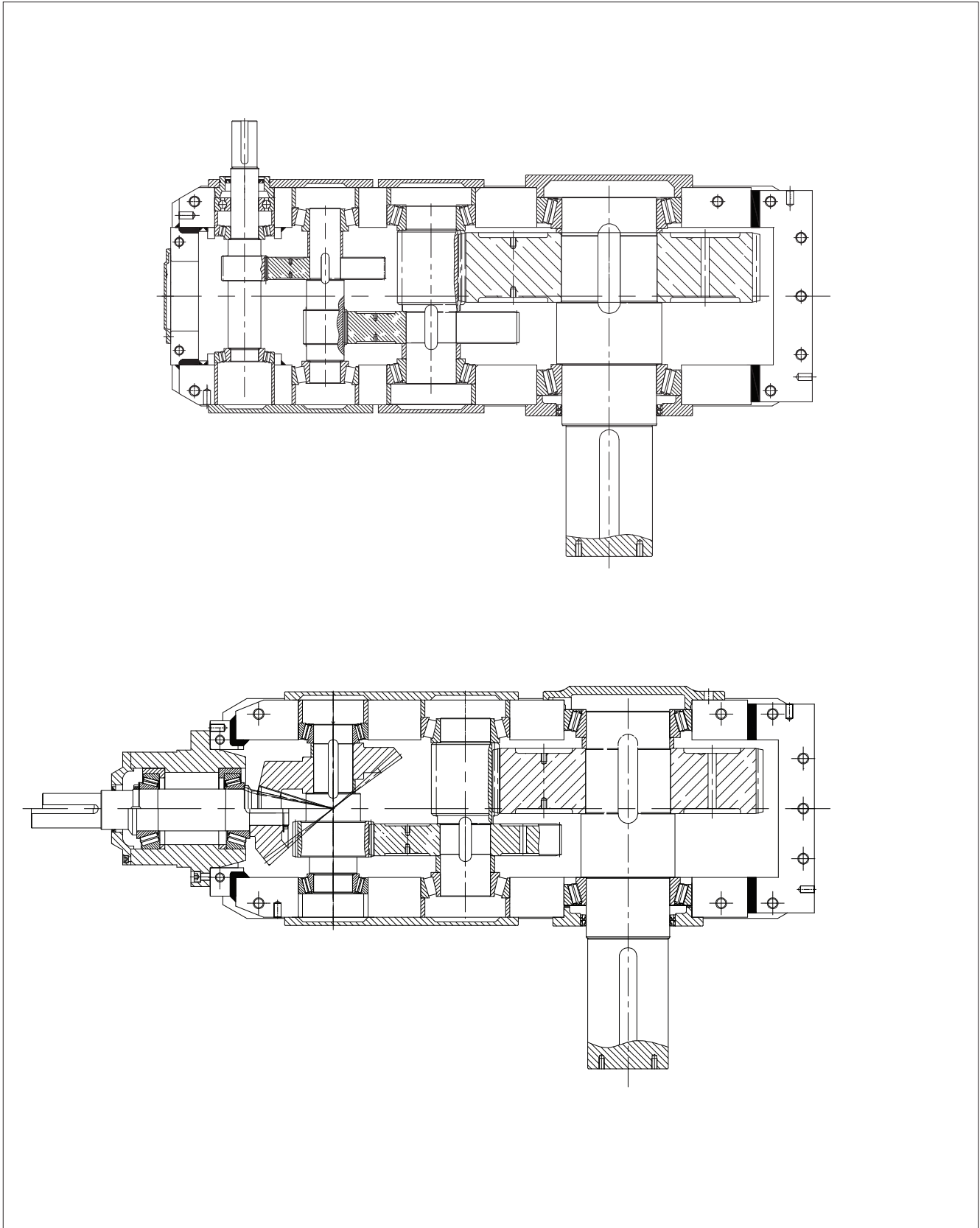

2 Mounting mode

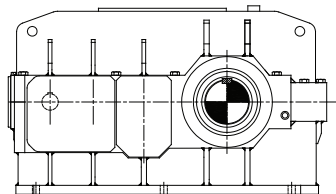
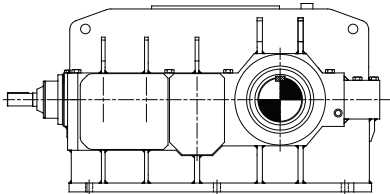
Horizontal mounting		
	H series (iN 8~450)	B series (iN 16~400)
Solid shaft	 <p>H...HS</p>	 <p>B...HS</p>

3 Type designation

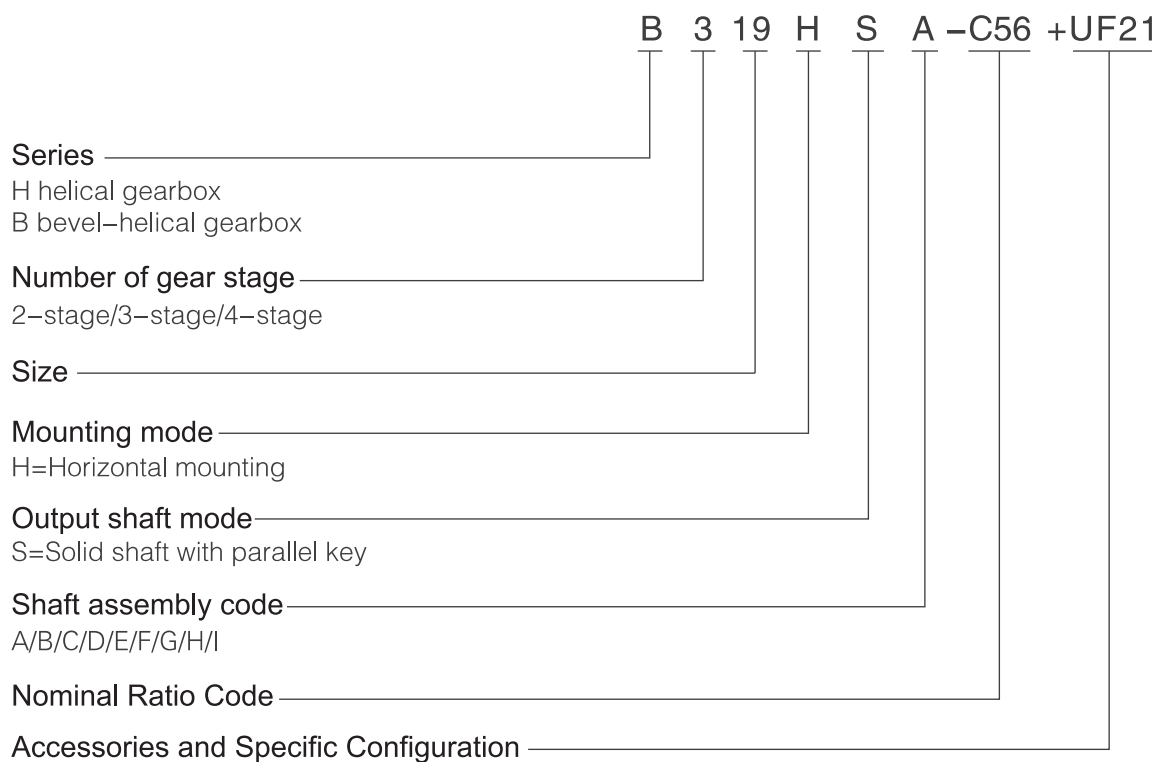

4 Selection

Serial	Definition	Symbol	Parameter calculation					
1	Driven equipment factor	f_1	Refer to page5 f_1 table					
2	Prime mover factor	f_2	Prime mover factor		f_2			
			Motor, hydraulic motor, turbine		1.0			
			4-6 Cylinder piston engine, cyclic variation 1:100 to 1: 200		1.25			
			1-3 Cylinder piston engine, cyclic variation 1:100		1.5			
3	Gearbox safety factor	S_F	Refer to page4 s_f table					
4	Relation between input and output shafts	H、B	Parallel shaft select H series, right angle, select B series					
5	Transmission efficiency of gearbox	η	2-stage:96%,3-stage:94%,4-stage:92%					
6	Input speed	n_1	$\leq 1800r/min$ For higher speed, please consult us.					
7	Determination of ratio	i	$i=n_1/n_2$					
8	Confirm gearbox input power with torque or power needed by driven equipment.	P_1	$P_1=T_2 \cdot n_1/(9550 \cdot i \cdot \eta)$ or $P_1=P_2 / \eta$					
9	According to calculation, check transmission capacity table to determine gearbox size	T_{2N} 、 P_{1N}	$T_{2N} \geq T_2 \cdot f_1 \cdot f_2 \cdot S_F$ OR $P_{1N} \geq P_1 \cdot f_1 \cdot f_2 \cdot S_F$ If it doesn't satisfy conditions: $3.33 \cdot P_1 \geq P_{1N}$, Please consult us.					
10	Peak torque verification*	T_A	$P_{1N} \geq T_A \cdot n_1 \cdot f_3/9550$	f_3		Load peaks per hour		
					1-5	6-30	31-100	>100
				Single direction loading	0.5	0.65	0.7	0.85
	Alternate loading	0.7	0.95	1.10	1.25			
11	After selecting connection mounting and accessories, check allowable strength of the shaft	F_{r1}/F_{r2} F_{a1}/F_{a2}	Radial load need to be checked when radial load imposed by belt pulley,chain sprocket and gear are present. (See page 23)					
12	Determine lubrication method, select lubrication oil	Horizontal mounting		Vertical mounting				
		Lubrication methods for selection: 1) Splash lubrication 2) Dip-in lubrication 3) Forced lubrication Shart end pump lubrication Motor oil pump lubrication Oil station lubrication		Lubrication methods for selection: 1) Dip-in lubrication 2) Forced lubrication Shart end pump lubrication Motor oil pump lubrication Oil station lubrication				
13	Determine cooling method		1) If it satisfies the following condition, the gearbox will not be equipped with auxiliary cooling device. $P_1 \leq P_{GA} \times f_4 \times f_8$ 2) If it satisfies the following condition, the gearbox will not be equipped with cooling fan. $P_1 \leq P_{GB} \times f_4 \times f_8$ 3) If it satisfies the following condition, the gearbox will not be equipped with water-oil cooler. $P_1 \leq P_{GD} \times f_5 \times f_8$ 4) Gearbox can be equipped with other cooling devides:air-oil cooler, water-oil cooler,users can equip petrol station by themselves to provide circulated cooling oil. (Refer to page 4 for f_4 、 f_5 、 f_8)					
14	Determine each item according to type designation		Refer to page2					

*Peak torque:maximum loading torque means the maximum torque caused by starting,braking or maximum pulse loading. (Under common working conditions,peak torque is the maximum torque may occur when a machine starts or brakes)

Gearbox safety factor		S _F
For ordinary equipment, only single machine stops production when gearbox fails.easy to replace spare parts and minor loss occurred.		1.0 ≤ S _F ≤ 1.3
For important equipment, the production line or the whole plant will stop production, when gearbox fails, great loss occurred, stopping accident loss is large.		1.3 < S _F ≤ 1.5
High reliability requirement,it may cause heavy production stop accident, when gearbox fails,causing large economic loss and even may cause human life accident.		1.5 < S _F

Thermal factor						f ₄
Gearbox without cooling or with fan						
Ambient temperature	Operating cycle per hour					
	100	80	60	40	20	
10°C	1.11	1.31	1.60	2.14	3.64	
20°C	1.00	1.18	1.44	1.93	3.28	
30°C	0.88	1.04	1.27	1.70	2.89	
40°C	0.75	0.89	1.08	1.45	2.46	
50°C	0.63	0.74	0.91	1.22	2.07	

Thermal factor						f ₅
Gear unit with water-oil cooler						
Ambient temperature	Operating cycle per hour					
	100	80	60	40	20	
10°C	1.05	1.23	1.50	2.03	3.41	
20°C	1.00	1.17	1.43	1.93	3.25	
30°C	0.93	1.09	1.33	1.79	3.02	
40°C	0.87	1.02	1.24	1.68	2.83	
50°C	0.81	0.95	1.16	1.56	2.63	

⚠ Note: Operating cycle ED: $ED = \frac{t_f}{t_f + t_r} \cdot 100\%$
 t_f: Working time with loading t_r: Stop time.

Vertical mounted gearbox oil supply factor . For horizontally mounted gearbox f ₈ =1.0; When forced lubrication applied,f ₈ =1.05						f ₈
Gearbox type	Oil supply method	Without auxiliary cooling device	With cooling fan	With cooling coil	With fan and cooling coil	
H2..V,H3..V H4..V	Dip-in lubrication	0.95	*	0.95	*	
	Forced lubrication	1.15	*	1.05	*	
B2..V,B3..V B4..V	Dip-in lubrication	0.95	0.95	0.95	0.95	
	Forced lubrication	1.15	1.10	1.10	1.10	

* Please consult us.

5 Service factor

Driven equipment factor							f ₁
Driven equipment	Daily operating time with load (hour)			Driven equipment	Daily operating time with load (hour)		
	≤2	>2-10	>10		≤2	>2-10	>10
Sewage treatment				Conveying machine			
Concentrator(Central Transmission)	–	–	1.2	Bucket conveyor	–	1.4	1.5
Compressed filter	1.0	1.3	1.5	Winch	1.4	1.6	1.6
Flocculator	0.8	1.0	1.3	Hoist	–	1.5	1.8
Aerator	–	1.8	2.0	Belt conveyor≤150kW	1.0	1.2	1.3
Collector	1.0	1.2	1.3	Belt conveyor≥150kW	1.1	1.3	1.4
Vertical,rotary group				Elevators for goods*	–	1.2	1.5
Blended collector	1.0	1.3	1.5	Elevators for customers*	–	1.5	1.8
Concentrator	–	1.1	1.3	Scraper conveyor	–	1.2	1.5
Screw pump	–	1.3	1.5	Automatic ladder	1.0	1.2	1.4
Water wheel machine	–	–	2.0	Rail traveling mechanism	–	1.5	–
Pump							
Centrifugal pump	1.0	1.2	1.3	Various frequency device	–	1.8	2.0
Volume-down pump							
1 Piston	1.3	1.4	1.8	Reciprocating compressor	–	1.8	1.9
>1 Piston	1.2	1.4	1.5				
Dredge				Hoisting mechanism**			
Bucket conveyor	–	1.6	1.6	Rotary mechanism*		1.4	1.8
Unloading device	–	1.3	1.5	Pitching mechanism		1.1	1.4
Caterpillar travelling mechanism	1.2	1.6	1.8	Traveling mechanism		1.6	2.0
Bucket digger				Lifting mechanism		1.1	1.4
Be used for picking up	–	1.7	1.7	Jibcrane		1.2	1.6
Be used for rough materials	–	2.2	2.2				
Chopper	–	2.2	2.2	Cooling tower			
Traveling mechanism*	–	1.4	1.8	Cooling tower fan	–	–	2.0
				Fan (Shaft flow and centrifugal type)	–	1.4	1.5
Plate blender	–	1.0	1.0				
Chemical industry				Food industry			
Extruder	–	–	1.6	Sugar production	–	–	1.7
Paste mixer	–	1.8	1.8	Sugar-cane cutter*			
Rubber calendar	–	1.5	1.5	Sugar crane mill	–	–	1.7
Cooling cylinder	–	1.3	1.4	Beet sugar production			
Material mixer, be used for				Beet masher	–	–	1.2
Uniform medium	1.0	1.3	1.4	Squeeze machine, mechanical refrigerator,			
Non-uniform medium	1.4	1.6	1.7	Cooking machine	–	–	1.4
Blender, be used for				Beet cleaner			
Uniform density medium	1.0	1.3	1.5	Beet chopper	–	–	1.5
Un-uniformed medium	1.2	1.4	1.6				
Un-uniformed gas absorption	1.4	1.6	1.8	Paper-making machinery			
Oven	1.0	1.3	1.5	Various kinds***	–	1.8	2.0
Centrifugal machine	1.0	1.2	1.3	Pulper driving device	Supply goods according to customer requirements		
				Centrifugal compressor	–	1.4	1.5
Metal processing equipment				Rope way cable car			
Plate turnover	1.0	1.0	1.2	Delivery ropeway	–	1.3	1.4
Steel pushing device	1.0	1.2	1.2	Cableway of shuttle system	–	1.6	1.8
Winding machine	–	1.6	1.6	T rod elevator	–	1.3	1.4
Cooling bed transverse frame	–	1.5	1.5	Continuous cableway	–	1.4	1.6
Roller leveler	–	1.6	1.6				
Roller path				Cement industry			
Continuous	–	1.5	1.5	Concrete blender	–	1.5	1.5
Interval	–	2.0	2.0	Crusher**	–	1.2	1.4
Reversing mill	–	1.8	1.8	Rotary kiln	–	–	2.0
Cutter				Tube mill	–	–	2.0
Continuous*	–	1.5	1.5	Powder concentrator	–	–	2.0
Crank type*	1.0	1.0	1.0	Roller press	–	1.6	1.6
Continuous casting driving device	–	1.4	1.4		–	–	2.0
Rolling mill							
Reversing cogging mill	–	2.5	2.5				
Reversing plate slab mill	–	2.5	2.5				
Reversing wire mill	–	1.8	1.8				
Reversing thin plate mill	–	2.0	2.0				
Reversing middle thickness plate mill	–	1.8	1.8				
Roll gap adjusting and driving device	0.9	1.0	–				

Driven equipment factor							f ₁
Driven equipment	Daily operating time with load (hour)			Driven equipment	Daily operating time with load (hour)		
	≤2	> 2-10	> 10		≤2	> 2-10	> 10
Wood industry				Plastics industry			
Barking machine				Miller, compound grinding、			
Feed drive	1.25	1.25	1.50	Coating, film、	1.25	1.25	1.25
Main drive	1.75	1.75	1.75	Conveying pipe, Pulling rod, thin type			
Conveyor				Pipe type, Pile drawer	1.25	1.25	1.50
Burner, repeating saw、	1.25	1.25	1.50	Continuous mixer, Calender、	1.50	1.50	1.50
Rotary tower, transit transport	1.50	1.50	1.50	Blow film, to plasticizing	1.75	1.75	1.75
Main loading, heavy loading	1.50	1.50	1.50	Batch mixer			
Main original wood, land base	1.75	1.75	2.00				
Conveying chain				Rubber industry			
Floor	1.50	1.50	1.50	Continuous strong inner mixer, Mix roller、	1.50	1.50	1.50
Green-wood	1.50	1.50	1.75	Batch feeding mixer (except for double sticks)			
Cutting Chain				Refiner, calender			
Saw transmission, traction	1.50	1.50	1.75	Double roller clamp feeding and mixed miller			
Peeling barrel	1.75	1.75	2.00	Batch strong inner mixer, Double stick single groove grain stick	1.25	1.25	1.50
Feed drive				Miller heater, double sticks			
Edging, wood trimmer、	1.25	1.25	1.50	Batch feeding mixer	1.75	1.75	1.75
Planer feed, assorting table、				Grinder, Crusher heater, double			
Automatic incline lifting				Rolls, Batch charing grinder	2.00	2.00	2.00
Multi-shaft feed, raw wood	1.75	1.75	1.75	Wave roll crusher			
Transportation and rotation				Generator and exciter	1.00	1.00	1.25
Transportation				Hammer crusher	1.75	1.75	2.00
Charging tray、	1.50	1.50	1.75	Sand miller	1.25	1.25	1.50
Plywood lathe drive、							
Conveying chain, Lifting							

- ⚠ Note: 1. Determine required power P2 of the driven equipment;
 *) Determine rated power according to maximum torque
 **) The actual service factor should be selected according to accurate loading classification, for specific information, please consult us.
 ***) It is necessary to check thermal capacity.
2. The factors are experience value. The premise of using these factors is that the above mechanical equipment should conform to common design regulation and loading conditions. If there is special situation, please consult us.
3. For machines that are not listed in this table, please consult us.

6 Key to symbols

Symbols	Instruction	Unit	
i	Actual ratio	/	
i_N	Nominal ratio		
i_{ex}	Exact ratio		
T_2	Output torque	$N \cdot m$	
T_{2N}	Reted output torque		
T_A	Max.Torque occurring on input shaft, e.g.Peak operating,starting or braking torque		
$T_{n2atmax}$	Nominal output torque at highest speed		
$T_{n2atmin}$	Nominal output torque at lowest speed		
P_{1N}	Rated input power	kW	
P_{GA}	Nominal thermal capacity of gearbox without auxiliary cooling equipment		
P_{GB}	Nominal thermal capacity gearbox with cooling fan		
P_{GD}	Normal thermal capacity of gearbox with water–oil cooler		
P_1	Input power		
P_2	Required power of driven machine		
f_1	Driven machine factor		/
f_2	Prime mover factor		
f_3	Peak load factor		
f_4	Thermal factor(Without auxiliary cooling,or witho fan cooling)		
f_5	Thermal factor(with water–oil cooler)		
f_8	Oil supply factor for vertical gearbox		
S_F	Safety factor of gearbox	r/min	
n_1	Input speed		
n_2	Output speed		
n_{2N}	Nominal output speed		
η	Efficiency	/	
f	Motor frequency	Hz	
U_m	Motor voltage	V	
ED	Operating cycle per hour	%	

7 Selection example

Known conditions:

Prime mover:

Motor power: 300kW

Motor speed: $n_1=960$ r/min

Maximum starting torque: $T_A=6000$ N.m

(This value is usually provided by the users.If not,normal torque x 1.6 preails)

Driven equipment (working machine):

Type: Belt conveyor

Speed: $n_2=15$ r/min

Required power: $P_1=280$ kW

Duty: 18 hours/day

Starts per hour: 3

Operating cycle per hour: 100%

Ambient temperature: $+20^\circ\text{C}$

Place of installation: Outdoor mounting

Altitude: 500m

Gear box:

Bevel-helical gearbox, horizontal mounting, with parallel key soild shaft output

Shaft arrangement form B

Selection procedure:

1. Calculation of ratio:

$$i = n_1/n_2 = 960/15 = 64$$

$$i_N = 63$$

2. Determine rated power of gear box

$$P_{1N} \geq P_1 \times f_1 \times f_2 \times S_F = 280 \times 1.6 \times 1 \times 1.3 = 582.4$$

Refer to transmission capacity table H3, select size 20

$$P_{1N} = 612 \text{ kW}$$

$$3.33 \times P_1 / \eta = 3.33 \times 280 / 0.94 = 991.91 \geq P_{1N} \text{ Satisfy requirements}$$

3. Peak torque verification

$$P_{1N} \geq T_A \times n_1 \times f_3 / 9550 = 6000 \times 960 \times 0.7 / 9550 = 422 \text{ kW}$$

$$P_{1N} = 612 \text{ kW} \geq 422 \text{ kW}$$

4. Verify thermal capacity:

$$P_{GA} \times f_4 \times f_8 = 324 \times 1 \times 1 = 324 \geq P_1 = 280 \text{ kW}, \text{ Satisfy requirements}$$

5. Determine gearbox type: H320HSB-C63

8 Transmission capacity table

H2 (iN=8-20)

Code	i_N	n_1 (r/min)	n_{2N} (r/min)	H219			H220			H221			H222		
				T_{2N} (kN·m)	i_{ex}	P_{1N} (kW)	T_{2N} (kN·m)	i_{ex}	P_{1N} (kW)	T_{2N} (kN·m)	i_{ex}	P_{1N} (kW)	T_{2N} (kN·m)	i_{ex}	P_{1N} (kW)
B80	8	1740	217.5	330	8.047	*			460	8.047	*				
		1450	181.3			*									
		1150	143.8			4938*									
		960	120.0			4122					5746				
B90	9	1740	193.3	330	8.824	*	380	9.106	460	8.824	*	520	8.880	*	
		1450	161.1			*									
		1150	127.8			4504*					5025*				
		960	106.7			3760					4195			5240	5887
C10	10	1740	174.0	330	9.963	*	380	9.985	460	9.963	*	520	9.737	*	
		1450	145.0			5029*					*				
		1150	115.0			3989*					4583*				
		960	96.0			3330					3826			4641	5368
C11	11.2	1740	155.4	330	11.176	5380*	380	11.274	460	11.176	*	520	10.994	*	
		1450	129.5			4483*					5118*			*	
		1150	102.7			3556					4059*			4956*	*
		960	85.7			2968					3388			4138	4755
C13	12.5	1740	139.2	330	12.641	4756*	380	12.647	460	12.641	*	520	12.333	*	
		1450	116.0			3964					4562*			*	
		1150	92.0			3144					3618*			4382*	5077*
		960	76.8			2624					3020			3658	4238
C14	14	1740	124.3	330	14.074	4272*	380	14.304	460	14.074	*	520	13.949	*	
		1450	103.6			3560					4034			4963*	*
		1150	82.1			2824					3199			3936*	4489*
		960	68.6			2357					2670			3286	3747
C16	16	1740	108.8	330	15.736	3821*	380	15.926	460	15.736	4347*	520	15.531	*	
		1450	90.6			3184					3623			4438*	5084*
		1150	71.9			2525					2873			3520*	4032*
		960	60.0			2108					2399			2939	3366
C18	18	1740	96.7	330	17.538	3428*	380	17.807	460	17.538	3888*	520	17.365	4779*	
		1450	80.6			2857					3240			3982*	4547*
		1150	63.9			2266					2570			3158*	3606*
		960	53.3			1891					2145			2637	3010
C20	20	1740	87.0				380	19.846			3489*	520	19.354	4895*	
		1450	72.5								2907				4079*
		1150	57.5								2306				3235*
		960	48.0								1925				2701

Forced lubrication required on horizontal gearbox.

*

On request.

H223			H224			H225			H226			n _{2N} (r/min)	n ₁ (r/min)	i _N	Code
T _{2N} (kN·m)	i _{ex}	P _{1N} (kW)	T _{2N} (kN·m)	i _{ex}	P _{1N} (kW)	T _{2N} (kN·m)	i _{ex}	P _{1N} (kW)	T _{2N} (kN·m)	i _{ex}	P _{1N} (kW)				
640	7.711	*										217.5	1740	8	B80
		*										181.3	1450		
		*										143.8	1150		
		8343*										120.0	960		
640	8.442	*	725	8.739	*							193.3	1740	9	B90
		*			161.1							1450			
		*			127.8							1150			
		7621*			106.7							960			
640	9.722	*	725	9.568	*	860	9.893		1030	9.914	*	174.0	1740	10	C10
		*			145.0						1450				
		*			115.0						1150				
		6617*			7617*						8739*	10444*	96.0		
640	10.727	*	725	11.018	*	860	11.324		1030	11.347	*	155.4	1740	11.2	C11
		*			129.5						1450				
		*			102.7						1150				
		5997			6615*						7634*	9125*	85.7		
640	11.887	*	725	12.157	*	860	12.447		1030	12.474	*	139.2	1740	12.5	C13
		*			116.0						1450				
		*			92.0						1150				
		5412			5995*						6945*	8300*	76.8		
640	13.809	*	725	13.472	*	860	13.744		1030	13.773	*	124.3	1740	14	C14
		*			103.6						1450				
		*			82.1						1150				
		4659			5410						6290*	7518*	68.6		
640	15.316	*	725	15.651	*	860	15.974		1030	16.007	*	108.8	1740	16	C16
		*			90.6						1450				
		*			71.9						1150				
		4201			4657						5412*	6468*	60.0		
640	17.064	*	725	17.358	*	860	17.647		1030	17.684	*	96.7	1740	18	C18
		*			80.6						1450				
		*			63.9						1150				
		3770			4199						4899*	5855*	53.3		
		*	725	19.339	*						*	87.0	1740	20	C20
		*			72.5						1450				
		*			57.5						1150				
		3769										48.0	960		

Forced lubrication required on horizontal gearbox.

* On request.

H3 (iN=16-90)

Code	i _N	n ₁ (r/min)	n _{2N} (r/min)	H319			H320			H321			H322				
				T _{2N} (kN·m)	i _{ex}	P _{1N} (kW)	T _{2N} (kN·m)	i _{ex}	P _{1N} (kW)	T _{2N} (kN·m)	i _{ex}	P _{1N} (kW)	T _{2N} (kN·m)	i _{ex}	P _{1N} (kW)		
C16	16	1740	108.8	330	15.210	3953*	380	15.368	4505*	460	17.090	4904*	520	18.859	5024*		
		1450	90.6			3294			3754							4087	4186
		1150	71.9			2613			2978							3241	3320
		960	60.0			2181			2486							2706	2772
C18	18	1740	96.7	330	17.428	3450*	380	17.212	4023*	460	17.090	4904*	520	18.859	5024*		
		1450	80.6			2875			3352			4087				4186	
		1150	63.9			2280			2659			3241				3320	
		960	53.3			1903			2219			2706				2772	
C20	20	1740	87.0	330	19.460	3090*	380	19.722	3511*	460	20.000	4191*	520	18.859	5024*		
		1450	72.5			2575			2926			3492				4186	
		1150	57.5			2042			2320			2770				3320	
		960	48.0			1705			1937			2312				2772	
C22	22.4	1740	77.7	330	21.809	2757*	380	22.021	3144*	460	22.787	3678*	520	22.070	4293*		
		1450	64.7			2297			2620			3065				3577	
		1150	51.3			1822			2078			2431				2837	
		960	42.9			1521			1735			2029				2368	
C25	25	1740	69.6	330	24.655	2439*	380	24.678	2806*	460	24.900	3366*	520	25.145	3768*		
		1450	58.0			2032			2338			2805				3140	
		1150	46.0			1612			1854			2225				2490	
		960	38.4			1345			1548			1857				2079	
C28	28	1740	62.1	330	26.667	2255*	380	27.899	2482*	460	28.148	2978*	520	27.478	3448*		
		1450	51.8			1879			2068			2481				2873	
		1150	41.1			1490			1640			1968				2279	
		960	34.3			1244			1369			1643				1902	
C32	31.5	1740	55.2	330	30.556	1968*	380	30.175	2294*	460	31.046	2700*	520	31.062	3050*		
		1450	46.0			1640			1912			2250				2542	
		1150	36.5			1301			1516			1784				2016	
		960	30.5			1086			1266			1489				1683	
C36	35.5	1740	49.0	330	34.118	1726*	380	34.576	2002*	460	34.604	2422*	520	34.259	2766*		
		1450	40.8			1469			1669			2018				2305	
		1150	32.4			1165			1323			1601				1828	
		960	27.0			972			1105			1336				1526	
C40	40	1740	43.5	330	38.235	1573*	380	38.607	1793*	460	39.118	2143*	520	38.186	2481*		
		1450	36.3			1310			1494			1785				2068	
		1150	28.8			1039			1185			1416				1640	
		960	24.0			868			989			1182				1369	
C45	45	1740	38.7	330	43.226	1391*	380	43.266	1600*	460	43.144	1943*	520	43.167	2195		
		1450	32.2			1159			1334			1619				1829	
		1150	25.6			919			1058			1284				1451	
		960	21.3			767			883			1072				1211	
C50	50	1740	34.8	330	48.276	1245	380	48.913	1415*	460	48.322	1734*	520	47.610	1990		
		1450	29.0			1038			1180			1445				1658	
		1150	23.0			823			936			1146				1315	
		960	19.2			687			781			957				1098	
C56	56	1740	31.1	330	55.172	1090	380	54.628	1267	460	54.260	1545*	520	53.324	1777		
		1450	25.9			908			1056			1287				1481	
		1150	20.5			720			838			1021				1174	
		960	17.1			601			699			852				980	
C63	63	1740	27.6	330	63.846	942	380	62.432	1109	460	60.025	1396*	520	59.876	1582		
		1450	23.0			785			924			1164				1319	
		1150	18.3			622			733			923				1046	
		960	15.2			520			612			770				873	
C71	71	1740	24.5	330	70.833	849	380	72.247	958	460	68.119	1230*	520	66.239	1430		
		1450	20.4			707			799			1025				1192	
		1150	16.2			561			633			813				945	
		960	13.5			468			529			679				789	
C80	80	1740	21.8	330	79.091	760	380	80.154	864	460	77.4	1260	520	75.170	1260		
		1450	18.1			634			720			1050				1050	
		1150	14.4			502			571			833				833	
		960	12.0			419			477			695				695	
C90	90	1740	19.3	330	89.498	774	380	89.498	774	460	89.498	1260	520	89.498	1260		
		1450	16.1			645			774			1050				1050	
		1150	12.8			511			511			833				833	
		960	10.7			427			427			695				695	

Forced lubrication required on horizontal gearbox.

* On request.

H323			H324			H325			H326			n _{2N} (r/min)	n ₁ (r/min)	i _N	Code		
T _{2N} (kN·m)	i _{ex}	P _{1N} (kW)	T _{2N} (kN·m)	i _{ex}	P _{1N} (kW)	T _{2N} (kN·m)	i _{ex}	P _{1N} (kW)	T _{2N} (kN·m)	i _{ex}	P _{1N} (kW)						
												108.8	1740	16	C16		
												90.6	1450				
												71.9	1150				
												60.0	960				
640	16.768	*				860	17.104	*	1030	17.140	*	96.7	1740	18	C18		
		*						*			80.6	1450					
		4596						6055			7236	63.9	1150				
		3837						5054			6041	53.3	960				
640	19.624	*	725	19.004	*	860	19.962	*	1030	20.004	*	87.0	1740	20	C20		
		*										*	72.5			1450	
		3927										5188	6200			57.5	1150
		3278										4331	5176			48.0	960
640	22.358	*	725	22.240	*	860	22.787	*	1030	22.835	*	77.7	1740	22.4	C22		
		*										*	64.7			1450	
		3447										4545	5432			51.3	1150
		2877										3794	4534			42.9	960
640	24.432	*	725	25.339	*	860	25.852	*	1030	25.907	*	69.6	1740	25	C25		
		*										*	58.0			1450	
		3154										4006	4788			46.0	1150
		2633										3344	3997			38.4	960
640	27.619	*	725	27.689	*	860	28.194	*	1030	28.253	*	62.1	1740	28	C28		
		*										*	51.8			1450	
		2790										3673	4390			41.1	1150
		2329										3066	3665			34.3	960
640	30.462	*	725	31.301	*	860	31.688	*	1030	31.755	*	55.2	1740	31.5	C32		
		*										*	46.0			1450	
		2530										3268	3906			36.5	1150
		2112										2728	3261			30.5	960
640	33.767	*	725	34.523	*	860	36.845	*	1030	36.922	*	49.0	1740	35.5	C36		
		*										*	40.8			1450	
		2282										2811	3359			32.4	1150
		1905										2346	2804			27.0	960
640	38.172	*	725	38.270	*	860	40.181	*	1030	40.266	*	43.5	1740	40	C40		
		*										*	36.3			1450	
		2019										2577	3080			28.8	1150
		1685										2152	2571			24.0	960
640	42.101	*	725	43.262	*	860	45.162	*	1030	45.257	*	38.7	1740	45	C45		
		*										*	32.2			1450	
		1831										2293	2741			25.6	1150
		1528										1914	2288			21.3	960
640	47.154	*	725	47.715	*	860	49.547	*	1030	49.651	*	34.8	1740	50	C50		
		*										*	29.0			1450	
		2061										2090	2498			23.0	1150
		1634										1745	2085			19.2	960
640	52.948	*	725	53.441	*	860	55.308	*	1030	55.424	*	31.1	1740	56	C56		
		*										*	25.9			1450	
		1835										1872	2238			20.5	1150
		1456										1563	1868			17.1	960
640	58.574	*	725	60.008	*	860	61.924	*	1030	62.054	*	27.6	1740	63	C63		
		*										*	23.0			1450	
		1659										2109	1999			18.3	1150
		1316										1672	1669			15.2	960
640	66.472	*	725	66.384	*	860	68.221	*	1030	68.365	*	24.5	1740	71	C71		
		*										*	20.4			1450	
		1462										1914	1814			16.2	1150
		1159										1518	1515			13.5	960
		*	725	75.335	*	860	77.002	*	1030	77.164	*	21.8	1740	80	C80		
		*										*	18.1			1450	
		1659										1696	1607			14.4	1150
		1159										1345	1342			12.0	960
		*			*			*			*	19.3	1740	90	C90		
		*										*	16.1			1450	
		1659										1345	1288			12.8	1150
		1159										1123	1077			9.6	960

Forced lubrication required on horizontal gearbox.

* On request.

H4 (iN=63-450)

Code	i _N	n ₁ (r/min)	n _{2N} (r/min)	H419			H420			H421			H422					
				T _{2N} (kN·m)	i _{ex}	P _{1N} (kW)	T _{2N} (kN·m)	i _{ex}	P _{1N} (kW)	T _{2N} (kN·m)	i _{ex}	P _{1N} (kW)	T _{2N} (kN·m)	i _{ex}	P _{1N} (kW)			
C63	63	1740	27.6															
		1450	23.0															
		1150	18.3															
		960	15.2															
C71	71	1740	24.5	330	68.391	879	380	68.635	1009	460	67.651	1239	520	65.724	1442			
		1450	20.4												733	841	1032	1201
		1150	16.2												581	667	819	953
		960	13.5												485	557	684	795
C80	80	1740	21.8	330	78.997	761	380	77.390	895	460	77.054	1088	520	74.653	1269			
		1450	18.1												634	746	906	1058
		1150	14.4												503	591	719	839
		960	12.0												420	494	600	700
C90	90	1740	19.3	330	90.115	667	380	89.391	775	460	84.253	995	520	85.029	1114			
		1450	16.1												556	645	829	929
		1150	12.8												441	512	657	736
		960	10.7												368	427	549	615
D10	100	1740	17.4	330	96.552	623	380	101.972	679	460	93.959	892	520	92.974	1019			
		1450	14.5												519	566	743	849
		1150	11.5												412	449	590	673
		960	9.6												344	375	492	562
D11	112	1740	15.5	330	104.338	576	380	109.256	634	460	106.894	784	520	103.685	914			
		1450	12.9												480	528	653	761
		1150	10.3												381	419	518	604
		960	8.6												318	350	433	504
D13	125	1740	13.9	330	126.083	477	380	118.067	586	460	120.939	693	520	117.958	803			
		1450	11.6												397	489	578	669
		1150	9.2												315	388	458	531
		960	7.7												263	324	382	443
D14	140	1740	12.4	330	145.636	413	380	142.673	485	460	137.749	608	520	133.457	710			
		1450	10.4												344	404	507	592
		1150	8.2												273	321	402	469
		960	6.9												228	268	336	392
D16	160	1740	10.9	330	166.133	362	380	164.799	420	460	150.620	556	520	152.007	623			
		1450	9.1												302	350	464	519
		1150	7.2												239	278	368	412
		960	6.0												200	232	307	344
D18	180	1740	9.7	330	178.000	338	380	187.993	368	460	167.970	499	520	166.210	570			
		1450	8.1												281	307	416	475
		1150	6.4												223	243	330	377
		960	5.3												186	203	275	314
D20	200	1740	8.7	330	192.355	313	380	201.421	344	460	191.094	439	520	185.357	511			
		1450	7.3												260	286	365	426
		1150	5.8												207	227	290	338
		960	4.8												172	190	242	282
D22	224	1740	7.8	330	222.500	270	380	217.665	318	460	215.962	388	520	210.874	449			
		1450	6.5												225	265	323	374
		1150	5.1												179	210	256	297
		960	4.3												149	175	214	248
D25	250	1740	7.0	330	248.586	242	380	251.776	275	460	248.008	338	520	238.316	398			
		1450	5.8												202	229	282	331
		1150	4.6												160	182	223	263
		960	3.8												133	152	186	219
D28	280	1740	6.2	330	280.185	215	380	281.295	246	460	283.836	295	520	273.679	346			
		1450	5.2												179	205	246	288
		1150	4.1												142	163	195	229
		960	3.4												118	136	163	191
D32	315	1740	5.5	330	309.720	194	380	317.052	218	460	312.773	268	520	313.215	302			
		1450	4.6												162	182	223	252
		1150	3.7												128	144	177	200
		960	3.0												107	120	148	167
D36	355	1740	4.9	330	348.261	173	380	350.473	198	460	351.938	238	520	345.147	275			
		1450	4.1												144	165	198	229
		1150	3.2												114	131	157	181
		960	2.7												95	109	131	151
D40	400	1740	4.4	330	385.667	156	380	394.085	176	460	387.004	217	520	388.367	244			
		1450	3.6												130	146	180	203
		1150	2.9												103	116	143	161
		960	2.4												86	97	119	135
D45	450	1740	3.9				380	436.412	159				520	427.062	222			
		1450	3.2													132		185
		1150	2.6													105		147
		960	2.1													88		122

H423			H424			H425			H426			n _{2N} (r/min)	n ₁ (r/min)	i _N	Code
T _{2N} (kN·m)	i _{ex}	P _{1N} (kW)	T _{2N} (kN·m)	i _{ex}	P _{1N} (kW)	T _{2N} (kN·m)	i _{ex}	P _{1N} (kW)	T _{2N} (kN·m)	i _{ex}	P _{1N} (kW)				
640	58.120	2006				860	60.164	2604	1030	60.291	3113	27.6	1740	63	C63
		1672						2170			2594	23.0	1450		
		1326						1721			2057	18.3	1150		
		1107						1437			1717	15.2	960		
640	66.015	1766	725	65.869	2005	860	68.603	2284	1030	68.748	2730	24.5	1740	71	C71
		1472			1671			2275			20.4	1450			
		1167			1325			1804			16.2	1150			
		975			1106			1506			13.5	960			
640	75.191	1551	725	74.817	1766	860	78.449	1997	1030	78.614	2387	21.8	1740	80	C80
		1292			1471			1989			18.1	1450			
		1025			1167			1578			14.4	1150			
		856			974			1317			12.0	960			
640	82.216	1418	725	85.216	1550	860	85.978	1822	1030	86.159	2178	19.3	1740	90	C90
		1182			1292			1815			16.1	1450			
		937			1024			1440			12.8	1150			
		783			855			1202			10.7	960			
640	91.688	1272	725	93.179	1418	860	97.636	1605	1030	97.842	1918	17.4	1740	100	D10
		1060			1181			1598			14.5	1450			
		841			937			1268			11.5	1150			
		702			782			1058			9.6	960			
640	104.309	1118	725	103.913	1271	860	106.835	1467	1030	107.060	1753	15.5	1740	112	D11
		932			1059			1461			12.9	1450			
		739			840			1159			10.3	1150			
		617			701			967			8.6	960			
640	118.015	988	725	118.217	1117	860	122.050	1284	1030	122.307	1534	13.9	1740	125	D13
		823			931			1279			11.6	1450			
		653			739			1014			9.2	1150			
		545			616			847			7.7	960			
640	134.419	867	725	133.750	988	860	139.566	1123	1030	139.860	1342	12.4	1740	140	D14
		723			823			1118			10.4	1450			
		573			653			887			8.2	1150			
		479			545			740			6.9	960			
640	146.978	793	725	152.341	867	860	152.961	1024	1030	153.283	1224	10.9	1740	160	D16
		661			723			1020			9.1	1450			
		524			573			809			7.2	1150			
		438			478			675			6.0	960			
640	163.910	711	725	166.575	793	860	173.702	902	1030	174.067	1078	9.7	1740	180	D18
		593			661			898			8.1	1450			
		470			524			713			6.4	1150			
		393			438			595			5.3	960			
640	186.474	625	725	185.764	711	860	190.067	824	1030	190.467	985	8.7	1740	200	D20
		521			593			821			7.3	1450			
		413			470			651			5.8	1150			
		345			392			544			4.8	960			
640	210.741	553	725	211.337	625	860	218.848	716	1030	219.309	856	7.8	1740	224	D22
		461			521			713			6.5	1450			
		366			413			566			5.1	1150			
		305			345			472			4.3	960			
640	242.012	482	725	238.840	553	860	243.164	644	1030	243.676	770	7.0	1740	250	D25
		402			461			642			5.8	1450			
		318			366			509			4.6	1150			
		266			305			425			3.8	960			
640	276.974	421	725	274.280	482	860	281.393	557	1030	281.985	666	6.2	1740	280	D28
		351			401			555			5.2	1450			
		278			318			440			4.1	1150			
		232			266			367			3.4	960			
640	305.211	382	725	313.904	421	860	312.188	502	1030	312.845	600	5.5	1740	315	D32
		318			351			500			4.6	1450			
		253			278			396			3.7	1150			
		211			232			331			3.0	960			
640	343.430	340	725	345.906	382	860	348.582	450	1030	349.315	537	4.9	1740	355	D36
		283			318			448			4.1	1450			
		224			252			355			3.2	1150			
		187			211			296			2.7	960			
640	377.648	309	725	389.220	339						4.4	1740	400	D40	
		257			283			3.6			1450				
		204			224			2.9			1150				
		170			187			2.4			960				
			725	428.001	309						3.9	1740	450	D45	
					257			3.2			1450				
					204			2.6			1150				
					170			2.1			960				

B3 (iN=16-90)

Code	i _N	n ₁ (r/min)	n _{2N} (r/min)	B319			B320			B321			B322		
				T _{2N} (kN·m)	i _{ex}	P _{1N} (kW)	T _{2N} (kN·m)	i _{ex}	P _{1N} (kW)	T _{2N} (kN·m)	i _{ex}	P _{1N} (kW)	T _{2N} (kN·m)	i _{ex}	P _{1N} (kW)
C16	16	1740	108.8	330	15.749	3818*	380	15.809	4380*						
		1450	90.6			3182*			3650*						
		1150	71.9			2523*			2895*						
		960	60.0			2106			2416						
C18	18	1740	96.7	330	18.235	3297*	380	17.821	3885*	460	17.593	4764*			
		1450	80.6			2748*			3238*						
		1150	63.9			2179*			2568*						
		960	53.3			1819			2143						
C20	20	1740	87.0	330	19.723	3048*	380	20.635	3355*	460	19.832	4226*	520	19.414	4880*
		1450	72.5			2540*			2796*						
		1150	57.5			2015			2218*						
		960	48.0			1682			1851						
C22	22.4	1740	77.7	330	23.098	2603*	380	22.318	3102*	460	22.963	3605*	520	21.884	4329*
		1450	64.7			2169			2585*						
		1150	51.3			1720			2050						
		960	42.9			1436			1712						
C25	25	1740	69.6	330	24.449	2459*	380	26.137	2649*	460	24.837	3374*	520	25.340	3739*
		1450	58.0			2049			2207						
		1150	46.0			1625			1751						
		960	38.4			1357			1461						
C28	28	1740	62.1	330	27.560	2182*	380	27.665	2503*	460	29.086	2882*	520	27.407	3457*
		1450	51.8			1818			2086						
		1150	41.1			1442			1654						
		960	34.3			1204			1381						
C32	31.5	1740	55.2	330	31.912	1884*	380	31.186	2059*	460	31.912	2626*	520	32.097	2952*
		1450	46.0			1570			1850						
		1150	36.5			1245			1467						
		960	30.5			1040			1225						
C36	35.5	1740	49.0	330	34.516	1742*	380	36.111	1917*	460	34.516	2428*	520	35.215	2690*
		1450	40.8			1452			1598						
		1150	32.4			1151			1267						
		960	27.0			961			1058						
C40	40	1740	43.5	330	40.422	1487*	380	39.057	1773*	460	40.422	2073*	520	38.088	2214*
		1450	36.3			1240			1477						
		1150	28.8			983			1172						
		960	24.0			821			978						
C45	45	1740	38.7	330	43.029	1397*	380	45.740	1514*	460	43.029	1948*	520	44.606	2124*
		1450	32.2			1164			1261						
		1150	25.6			924			1000						
		960	21.3			771			835						
C50	50	1740	34.8	330	49.649	1211*	380	48.691	1422*	460	49.649	1688*	520	47.483	1995*
		1450	29.0			1009			1185						
		1150	23.0			800			940						
		960	19.2			668			785						
C56	56	1740	31.1	330	53.787	1118*	380	56.182	1232*	460	53.787	1558*	520	54.788	1729*
		1450	25.9			932			1027						
		1150	20.5			739			814						
		960	17.1			617			680						
C63	63	1740	27.6	330	60.632	992*	380	60.864	1138*	460	60.632	1382*	520	59.354	1596*
		1450	23.0			826			948						
		1150	18.3			655			752						
		960	15.2			547			628						
C71	71	1740	24.5	330	69.542	865*	380	68.610	1009*	460	69.542	1205*	520	66.908	1416*
		1450	20.4			720			841						
		1150	16.2			571			667						
		960	13.5			477			557						
C80	80	1740	21.8	330	75.790	793*	380	78.693	880*	460	75.790	1106*	520	76.741	1235*
		1450	18.1			661			733						
		1150	14.4			524			581						
		960	12.0			438			485						
C90	90	1740	19.3	330	85.570	703*	380	85.763	807*	460	85.570	979*	520	83.635	1133*
		1450	16.1			586			673						
		1150	12.8			464			534						
		960	10.7			388			445						

Forced lubrication required on horizontal gearbox.

* On request.

B323			B324			B325			B326			n _{2N} (r/min)	n ₁ (r/min)	i _N	Code
T _{2N} (kN·m)	i _{ex}	P _{1N} (kW)	T _{2N} (kN·m)	i _{ex}	P _{1N} (kW)	T _{2N} (kN·m)	i _{ex}	P _{1N} (kW)	T _{2N} (kN·m)	i _{ex}	P _{1N} (kW)				
												108.8	1740	16	C16
												90.6	1450		
												71.9	1150		
												60.0	960	18	C18
												96.7	1740		
												80.6	1450		
												63.9	1150	20	C20
												53.3	960		
												87.0	1740		
640	19.652	*										72.5	1450	22.4	C22
		*										57.5	1150		
		3274										48.0	960		
640	22.215	*	725	22.272	*	860	22.541	*	1030	22.588	*	77.7	1740	25	C25
		*			*			*			*	64.7	1450		
		*			*			*			*	51.3	1150		
		2896			3272			3835			4584	42.9	960	28	C28
		*			*			*			*	69.6	1740		
		*			*			*			*	58.0	1450		
640	24.988	*	725	25.177	*	860	25.098	*	1030	25.151	*	46.0	1150	31.5	C32
		*			*			*			*	38.4	960		
		2575			2895			3445			4117	62.1	1740		
640	28.386	*	725	28.320	*	860	28.143	*	1030	28.202	*	51.8	1450	35.5	C36
		*			*			*			*	41.1	1150		
		*			*			*			*	34.3	960		
		2266			2573			3072			3671	55.2	1740	40	C40
		*			*			*			*	46.0	1450		
		*			*			*			*	36.5	1150		
		2095			2265			2691			3216	30.5	960	45	C45
		*			*			*			*	49.0	1740		
		*			*			*			*	40.8	1450		
		1863			2094			2417			2889	32.4	1150	50	C50
		*			*			*			*	27.0	1740		
		*			*			*			*	23.0	1450		
		1570			1806			2069			2473	23.0	1150	56	C56
		*			*			*			*	31.1	1740		
		1311			1507			1727			2064	25.9	1450		
		*			*			*			*	20.5	1150	63	C63
		*			*			*			*	27.6	1740		
		1458			1570			1954			2335	23.0	1450		
		1217			1310			1631			1949	28.8	1150	71	C71
		*			*			*			*	24.5	1740		
		*			*			*			*	20.4	1450		
		1269			1457			1724			2060	16.2	1150	80	C80
		1059			1217			1439			1720	15.2	960		
		*			*			*			*	24.5	1740		
		*			*			*			*	20.4	1450	90	C90
		1136			1268			1527			1825	13.5	960		
		948			1059			1275			1524	21.8	1740		
		*			*			*			*	18.1	1450	90	C90
		*			*			*			*	14.4	1150		
		1038			1135			1292			1545	12.0	960		
		867			948			1079			1289	19.3	1740	90	C90
		*			*			*			*	16.1	1450		
			725	84.120	1309							12.8	1150		
					1038							10.7	960		
					866										

Forced lubrication required on horizontal gearbox.

* On request.

B4 (iN=90-400)

Code	i _N	n ₁ (r/min)	n _{2N} (r/min)	B419			B420			B421			B422		
				T _{2N} (kN·m)	i _{ex}	P _{1N} (kW)	T _{2N} (kN·m)	i _{ex}	P _{1N} (kW)	T _{2N} (kN·m)	i _{ex}	P _{1N} (kW)	T _{2N} (kN·m)	i _{ex}	P _{1N} (kW)
C90	90	1740	19.3												
		1450	16.1												
		1150	12.8												
		960	10.7												
D10	100	1740	17.4	330	96.552	623*	380	96.402	718*	460	96.644	867*	520	94.100	1007*
		1450	14.5			519			598			723			839
		1150	11.5			412			475			573			665
		960	9.6			344			396			478			555
D11	112	1740	15.5	330	111.250	540*	380	109.256	634*	460	107.981	776*	520	106.647	888*
		1450	12.9			450			528			647			740
		1150	10.3			357			419			513			587
		960	8.6			298			350			428			490
D13	125	1740	13.9	330	125.409	479*	380	125.888	550*	460	121.724	689*	520	119.158	795*
		1450	11.6			400			458			574			663
		1150	9.2			317			363			455			526
		960	7.7			265			303			380			439
D14	140	1740	12.4	330	145.211	414*	380	141.910	488*	460	140.944	595*	520	134.324	705*
		1450	10.4			345			407			496			588
		1150	8.2			274			322			393			466
		960	6.9			228			269			328			389
D16	160	1740	10.9	330	157.059	383*	380	164.317	421*	460	152.444	550*	520	155.533	609*
		1450	9.1			319			351			458			508
		1150	7.2			253			278			363			403
		960	6.0			211			232			303			336
D18	180	1740	9.7	330	178.000	338*	380	177.724	390*	460	172.770	485*	520	168.223	563*
		1450	8.1			281			325			404			469
		1150	6.4			223			257			321			372
		960	5.3			186			215			268			311
D20	200	1740	8.7	330	195.800	307*	380	201.421	344*	460	190.047	441*	520	190.653	497*
		1450	7.3			256			286			368			414
		1150	5.8			203			227			291			328
		960	4.8			169			190			243			274
D22	224	1740	7.8	330	225.923	266*	380	221.563	312*	460	219.285	382*	520	209.718	452*
		1450	6.5			222			260			319			376
		1150	5.1			176			207			253			299
		960	4.3			147			172			211			249
D25	250	1740	7.0	330	244.750	246*	380	255.650	271*	460	237.558	353*	520	241.982	392*
		1450	5.8			205			226			294			326
		1150	4.6			162			179			233			259
		960	3.8			136			149			195			216
D28	280	1740	6.2	330	275.900	218*	380	276.954	250*	460	267.793	313*	520	262.148	361*
		1450	5.2			182			208			261			301
		1150	4.1			144			165			207			239
		960	3.4			120			138			173			199
D32	315	1740	5.5	330	316.444	190*	380	312.203	222*	460	307.146	273*	520	295.512	321*
		1450	4.6			158			185			227			267
		1150	3.7			126			147			180			212
		960	3.0			105			122			151			177
D36	355	1740	4.9	330	344.875	174*	380	358.082	193*	460	334.741	250*	520	338.938	280*
		1450	4.1			145			161			209			233
		1150	3.2			115			128			165			185
		960	2.7			96			107			138			154
D40	400	1740	4.4				380	390.253	177*	460	377.934	222*	520	369.390	256*
		1450	3.6						148			185			214
		1150	2.9						117			147			170
		960	2.4						98			122			142

Forced lubrication required on horizontal gearbox.

* On request.

B423			B424			B425			B426			n _{2N} (r/min)	n ₁ (r/min)	i _N	Code	
T _{2N} (kN·m)	i _{ex}	P _{1N} (kW)	T _{2N} (kN·m)	i _{ex}	P _{1N} (kW)	T _{2N} (kN·m)	i _{ex}	P _{1N} (kW)	T _{2N} (kN·m)	i _{ex}	P _{1N} (kW)					
640	83.212	*				860	87.435		1030	87.619	*	19.3	1740	90	C90	
		1168									1493	1785	16.1			1450
		926									1184	1416	12.8			1150
		773									989	1182	10.7			960
640	94.307	*	725	94.307	*	860	102.397	*	1030	102.612	*	17.4	1740	100	D10	
		1030			1167			1275			1524	14.5	1450			
		817			926			1011			1209	11.5	1150			
		682			773			844			1009	9.6	960			
640	105.370	*	725	106.881	*	860	110.184	*	1030	110.416	*	15.5	1740	112	D11	
		922			1030			1185			1416	12.9	1450			
		731			817			940			1123	10.3	1150			
		611			682			785			938	8.6	960			
640	118.781	*	725	119.420	*	860	124.207	*	1030	124.469	*	13.9	1740	125	D13	
		818			922			1051			1256	11.6	1450			
		649			731			834			996	9.2	1150			
		542			610			696			832	7.7	960			
640	137.536	*	725	134.619	*	860	143.819	*	1030	144.122	*	12.4	1740	140	D14	
		707			818			908			1085	10.4	1450			
		560			649			720			861	8.2	1150			
		468			541			601			718	6.9	960			
640	148.758	*	725	155.874	*	860	155.554	*	1030	155.881	*	10.9	1740	160	D16	
		653			706			839			1003	9.1	1450			
		518			560			666			796	7.2	1150			
		432			468			556			664	6.0	960			
640	168.593	692	725	168.593	*	860	182.171	860	1030	182.554	1028	9.7	1740	180	D18	
		576			653			717			857	8.1	1450			
		457			518			568			679	6.4	1150			
		382			432			475			567	5.3	960			
640	185.452	629	725	191.072	691	860	193.924	808	1030	194.332	966	8.7	1740	200	D20	
		524			576			673			805	7.3	1450			
		416			457			534			638	5.8	1150			
		347			381			446			533	4.8	960			
640	213.983	545	725	210.179	628	860	223.758	700	1030	224.229	837	7.8	1740	224	D22	
		454			524			584			697	6.5	1450			
		360			415			463			553	5.1	1150			
		301			347			386			462	4.3	960			
640	231.815	503	725	242.514	545	860	242.404	646	1030	242.915	773	7.0	1740	250	D25	
		419			454			539			644	5.8	1450			
		332			360			427			511	4.6	1150			
		278			301			357			426	3.8	960			
640	261.319	446	725	262.724	503	860	273.256	573	1030	273.831	685	6.2	1740	280	D28	
		372			419			478			571	5.2	1450			
		295			332			379			453	4.1	1150			
		246			277			316			378	3.4	960			
640	299.720	389	725	296.161	446	860	313.412	500	1030	314.072	598	5.5	1740	315	D32	
		324			372			417			498	4.6	1450			
		257			295			330			395	3.7	1150			
		215			246			276			330	3.0	960			
640	326.648	357	725	339.683	389	860	341.570	459	1030	342.289	548	4.9	1740	355	D36	
		297			324			382			457	4.1	1450			
		236			257			303			362	3.2	1150			
		197			215			253			302	2.7	960			
			725	370.202	357							4.4	1740	400	D40	
					297							3.6	1450			
					236							2.9	1150			
					197							2.4	960			

Forced lubrication required on horizontal gearbox.

* On request.

9 Rated thermal capacity table

H2 (kW)

Code	i _N		H219				H220				H221				H222				H223	H224	H225	H226	
			960	1150	1450	1740	960	1150	1450	1740	960	1150	1450	1740	960	1150	1450	1740					
B80	8	PGA	*	*	*	*					*	*	*	*					*				
B90	9	PGA	*	*	*	*	*	*	*	*	*	*	*	*	*	*	*	*	*	*	*		
C10	10	PGA	*	*	*	*	*	*	*	*	*	*	*	*	*	*	*	*	*	*	*	*	*
C11	11.2	PGA	*	*	*	*	*	*	*	*	*	*	*	*	*	*	*	*	*	*	*	*	*
C13	12.5	PGA	301	*	*	*	289	*	*	*	*	*	*	*	*	*	*	*	*	*	*	*	*
C14	14	PGA	328	*	*	*	333	*	*	*	*	*	*	*	*	*	*	*	*	*	*	*	*
C16	16	PGA	341	*	*	*	354	*	*	*	336	*	*	*	*	*	*	*	*	*	*	*	*
C18	18	PGA	362	*	*	*	368	*	*	*	367	*	*	*	352	*	*	*	*	*	*	*	*
C20	20	PGA					378	*	*	*					372	*	*	*		*			

H3 (kW)

Code	i _N		H319				H320				H321				H322				H323	H324	H325	H326	
			960	1150	1450	1740	960	1150	1450	1740	960	1150	1450	1740	960	1150	1450	1740					
C16	16	PGA	341	*	*	*																	
C18	18	PGA	362	*	*	*	368	*	*	*	367	*	*	*					*		*	*	*
C20	20	PGA	361	264	*	*	378	*	*	*	373	*	*	*	372	*	*	*	*	*	*	*	*
C22	22.4	PGA	325	232	*	*	369	267	*	*	350	*	*	*	362	*	*	*	*	*	*	*	*
C25	25	PGA	323	234	*	*	333	235	*	*	363	*	*	*	343	*	*	*	*	*	*	*	*
C28	28	PGA	326	252	222	*	338	255	*	*	380	*	*	*	370	*	*	*	*	*	*	*	*
C32	31.5	PGA	327	267	246	*	341	274	249	*	394	276	*	*	389	*	*	*	*	*	*	*	*
C36	35.5	PGA	325	279	268	208	342	290	276	*	404	311	273	*	404	292	*	*	*	*	*	*	*
C40	40	PGA	317	279	272	223	336	293	283	227	401	322	293	*	407	310	269	*	*	*	*	*	*
C45	45	PGA	316	281	276	231	326	287	280	230	393	321	297	*	402	313	278	*	*	*	*	*	*
C50	50	PGA	320	300	304	280	332	309	313	285	410	365	360	303	410	356	344	274	*	*	*	*	*
C56	56	PGA	311	300	310	298	332	319	329	315	401	374	379	347	421	386	387	343	*	*	*	*	*
C63	63	PGA	295	293	307	307	324	320	336	334	393	382	397	386	413	398	411	394	*	*	*	*	*
C71	71	PGA	292	290	306	307	303	301	316	317	373	365	381	374	397	385	400	387	*	*	*	*	*
C80	80	PGA	277	277	292	295	299	299	315	317					377	368	384	376		*	*	*	*
C90	90	PGA					283	284	300	304													

* :On request.

H4 (kW)

Code	iN		H419				H420				H421				H422				H423	H424	H425	H426
			960	1150	1450	1740	960	1150	1450	1740	960	1150	1450	1740	960	1150	1450	1740				
C63	63	PGA																	*		*	*
C71	71	PGA	292	290	306	307	303	301	316	317	373	365	381	374	397	385	400	387	*		*	*
C80	80	PGA	277	277	292	295	299	299	315	317	358	352	369	365	377	368	384	376	*		*	*
C90	90	PGA	263	264	280	284	283	284	300	304	349	345	363	362	361	355	372	368	*		*	*
D10	100	PGA	253	246	264	263	272	276	294	303	346	325	348	335	356	358	379	385	*		*	*
D11	112	PGA	243	241	259	262	260	257	276	279	340	329	352	349	350	335	358	351	*		*	*
D13	125	PGA	235	237	254	259	249	250	268	273	330	325	348	350	344	335	359	358	*		*	*
D14	140	PGA	227	231	248	255	241	245	263	271	313	314	336	343	334	332	356	361	*		*	*
D16	160	PGA	218	224	240	249	232	238	255	265	301	305	327	336	317	319	342	350	*		*	*
D18	180	PGA	208	216	232	243	224	232	249	261	297	306	329	342	304	313	335	348	*		*	*
D20	200	PGA	201	211	226	238	214	224	240	253	280	292	314	329	300	313	335	352	*		*	*
D22	224	PGA	193	204	219	232	206	217	233	247	268	283	303	321	283	299	321	340	*		*	*
D25	250	PGA	183	193	208	220	198	209	224	237	253	267	287	304	270	285	305	323	*		*	*
D28	280	PGA	176	186	199	211	188	198	213	225	243	257	276	292	255	269	289	306	*		*	*
D32	315	PGA	172	182	195	207	181	191	204	216	233	246	264	280	245	259	278	294	*		*	*
D36	355	PGA	164	173	186	197	177	187	200	212	222	235	252	267	236	249	267	283	*		*	*
D40	400	PGA					168	177	190	201	*	*	*	*	225	238	255	270	*			
D45	450	PGA					*	*	*	*					*	*	*	*				

* :On request.

B3 (kW)

Code	iN		B319				B320				B321				B322				B323	B324	B325	B326
			960	1150	1450	1740	960	1150	1450	1740	960	1150	1450	1740	960	1150	1450	1740				
C16	16	PGA	*	*	*	*	*	*	*	*												
		PGB	*	*	*	*	*	*	*	*												
C18	18	PGA	*	*	*	*	*	*	*	*	*	*	*	*								
		PGB	*	*	*	*	*	*	*	*	*	*	*	*								
20	20	PGA	271	211	*	*	*	*	*	*	270	*	*	*	*	*	*	*	*			
		PGB	814	865	839	761	*	*	*	*	899	920	813	622	*	*	*	*	*			
C22	22.4	PGA	276	222	*	*	286	226	*	*	279	*	*	*	270	*	*	*	*	*	*	
		PGB	795	850	836	774	833	888	864	789	881	910	824	661	907	920	793	576	*	*	*	*
C25	25	PGA	281	241	*	*	297	250	*	*	292	*	*	*	291	*	*	*	*	*	*	
		PGB	763	826	833	803	816	880	881	840	846	889	841	732	893	926	844	688	*	*	*	*
C28	28	PGA	285	257	200	*	241	269	*	*	301	244	*	*	306	*	*	*	*	*	*	
		PGB	731	800	828	826	826	854	878	869	811	868	855	794	857	906	869	773	*	*	*	*
C32	31.5	PGA	279	260	216	*	302	279	227	*	299	257	*	*	312	256	*	*	*	*	*	
		PGB	688	760	799	814	782	824	863	874	759	822	831	802	821	881	871	815	*	*	*	*
C36	35.5	PGA	278	265	228	*	302	277	235	*	297	265	*	*	306	263	*	*	*	*	*	
		PGB	666	739	786	813	749	779	825	849	731	798	821	813	767	830	839	810	*	*	*	*
4C0	40	PGA	267	258	266	175	293	277	240	*	287	262	208	*	302	266	*	*	*	*	*	
		PGB	627	698	747	779	703	754	805	836	686	753	783	786	728	804	822	808	*	*	*	*
C45	45	PGA	253	247	221	179	289	270	240	190	270	251	207	*	291	263	206	*	*	*	*	
		PGB	582	650	700	737	679	712	765	801	634	698	733	746	692	758	785	785	*	*	*	*
C50	50	PGA	256	257	240	212	278	266	247	216	302	293	260	206	283	269	232	*	*	*	*	
		PGB	561	631	690	739	638	669	730	780	668	744	799	837	641	712	757	783	*	*	*	*
C56	56	PGA	251	256	245	229	267	272	260	240	294	293	271	236	312	307	279	234	*	*	*	*
		PGB	540	611	675	731	595	645	712	771	630	708	772	823	675	755	818	866	*	*	*	*
C63	63	PGA	245	251	243	231	268	266	256	242	287	289	272	244	295	297	275	240	*	*	*	*
		PGB	520	589	654	712	571	622	689	750	608	686	752	808	633	712	776	828	*	*	*	*
C71	71	PGA	232	239	232	222	260	259	251	239	272	275	261	238	291	292	273	243	*	*	*	*
		PGB	487	553	615	671	549	600	666	726	569	643	707	763	612	689	754	808	*	*	*	*
C80	80	PGA	*	*	*	*	252	247	240	231	*	*	*	*	276	278	262	237	*	*	*	*
		PGB	*	*	*	*	529	563	626	684	*	*	*	*	574	647	710	764	*	*	*	*
C90	90	PGA	*	*	*	*	*	*	*	*	*	*	*	*	*	*	*	*		*		
		PGB	*	*	*	*	*	*	*	*	*	*	*	*	*	*	*	*		*		

* :On request.

B4 (kW)

Code	iN		B419				B420				B421				B422				B423	B424	B425	B426
			960	1150	1450	1740	960	1150	1450	1740	960	1150	1450	1740	960	1150	1450	1740				
C90	90	PGA																	*		*	*
D10	100	PGA	227	228	236	230	246	247	255	247	319	311	321	301	344	330	339	312	*	*	*	*
D11	112	PGA	216	219	227	223	232	235	243	238	309	306	315	300	322	314	323	302	*	*	*	*
D13	125	PGA	205	210	218	216	221	226	234	231	291	291	300	290	313	309	318	303	*	*	*	*
D14	140	PGA	198	204	211	212	211	217	225	224	281	284	294	288	294	294	304	294	*	*	*	*
D16	160	PGA	187	194	202	204	203	210	218	220	265	271	281	278	284	288	298	292	*	*	*	*
D18	180	PGA	175	183	190	194	191	200	208	211	248	256	266	266	269	276	286	285	*	*	*	*
D20	200	PGA	174	183	191	196	179	189	196	201	240	251	260	264	251	261	271	274	*	*	*	*
D22	224	PGA	163	174	181	187	179	190	198	205	224	237	246	253	243	256	266	273	*	*	*	*
D25	250	PGA	158	169	176	184	168	180	187	195	217	232	241	251	227	243	252	262	*	*	*	*
D28	280	PGA	148	160	167	175	161	174	182	191	207	224	233	245	220	237	247	260	*	*	*	*
D32	315	PGA	140	152	158	166	153	165	172	180	193	209	217	228	240	227	236	248	*	*	*	*
D36	355	PGA	*	*	*	*	144	155	162	170	*	*	*	*	196	211	220	231	*	*	*	*
D40	400	PGA					*	*	*	*	*	*	*	*	*	*	*	*		*		

* :On request.

10 Permissible Additional Radial Forces on Output Shaft

10.1 Permissible Additional Radial Forces on Output Shaft d2

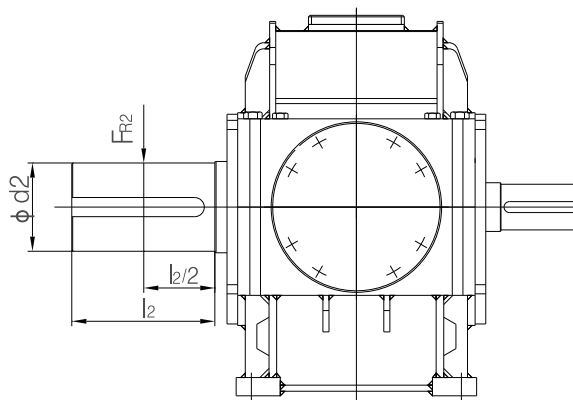

Permissible Additional Radial Forces F_{R2} (kN) acting on the center of the output shaft**

Type	Design	19	20	21	22	23	24	25	26
H2. . HS	A+B+G+H	365	372	395	400	470	465	460	530
	C+D	284	305	308	330	365	380	355	430
H3. . HS	A+B+G+H	365	372	395	400	470	465	460	530
	C+D	284	305	308	330	365	380	355	430
H4. . HS	C+D	365	372	395	400	470	465	460	530
	A+B+G+H	284	305	308	330	365	380	355	430
B3. . HS	A+C	365	372	395	400	470	465	460	530
	B+D	284	305	308	330	365	380	355	430
B4. . HS	A+C	365	372	395	400	470	465	460	530
	B+D	284	305	308	330	365	380	355	430

- Note: 1) If angle of action and direction of swing of the force are known, in most cases, higher radial force can be allowed. Please consult us.
 2) *Upon request.
 3) **Permissible Additional Radial Forces F_{R2} (kN) acting on the center of the output shaft. For application of force outside the center of the shaft end, see 10.2.
 4) The min requirement of the foundation bolt is class 8.8. The foundation must be dry and grease-free. Permissible additional radial force on input shaft d1 is upon request.

10.2 Permissible Additional Radial Forces on Output Shaft d2

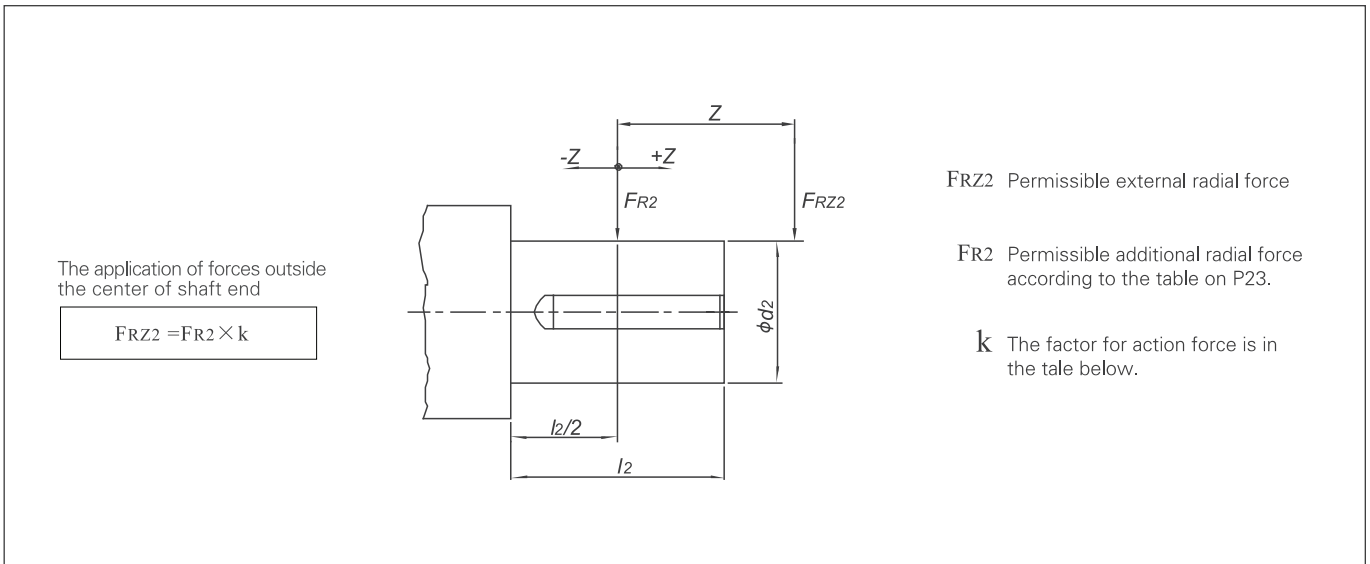

Factor for action force (k)

Size	Distance Z (mm)																			
	-350	-300	-250	-200	-150	-100	-75	-50	-25	0	25	50	75	100	150	200	250	300	350	400
19/20				1.22	1.13	1.1	1.06	1.04	1.02	1	0.95	0.9	0.85	0.81	0.74	0.69	0.62	0.58		
21/22			1.27	1.21	1.12	1.09	1.05	1.04	1.02	1	0.96	0.92	0.86	0.83	0.75	0.71	0.64	0.6		
23/24			1.27	1.2	1.1	1.08	1.04	1.03	1.02	1	0.97	0.93	0.87	0.84	0.77	0.72	0.65	0.61		
25/26		1.29	1.22	1.18	1.09	1.07	1.03	1.03	1.02	1	0.98	0.96	0.87	0.83	0.76	0.7	0.64	0.61	0.55	0.51

- Note: 1) FRZ2: Permissible external radial force when the application of forces outside the center of shaft end.
 2) FR2: Permissible additional radial force according to the table on P23.
 3) k: The factor for action force is in the table below.

11 Shaft assemblies

11.1 H series shaft assemblies

11.1.1 Shaft assemblies

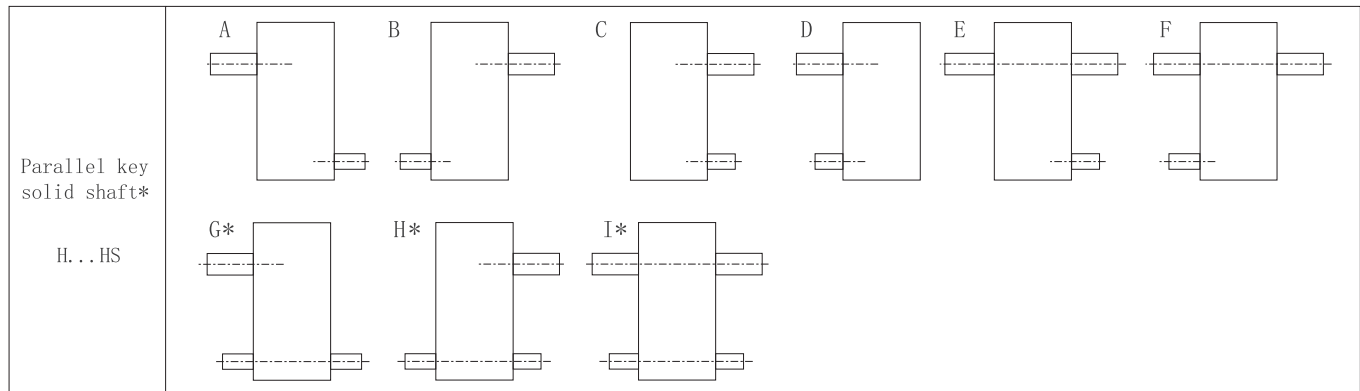

Type	Size	19	20	21	22	23	24	25	26
	iN								
H2		8~12.5	9~14	8~12.5	9~14	8~12.5	9~14	10	10
H3		16~56	16~56	18~56	20~63	18~56	20~63	/	/
H4		71~250	71~280	71~250	71~280	63~250	71~280	63~250	63~250

Note: *)Shaft assemblies G/H/I is available when nominal ratio is within the range of value showed in above table.

11.1.2 Direction of rotation

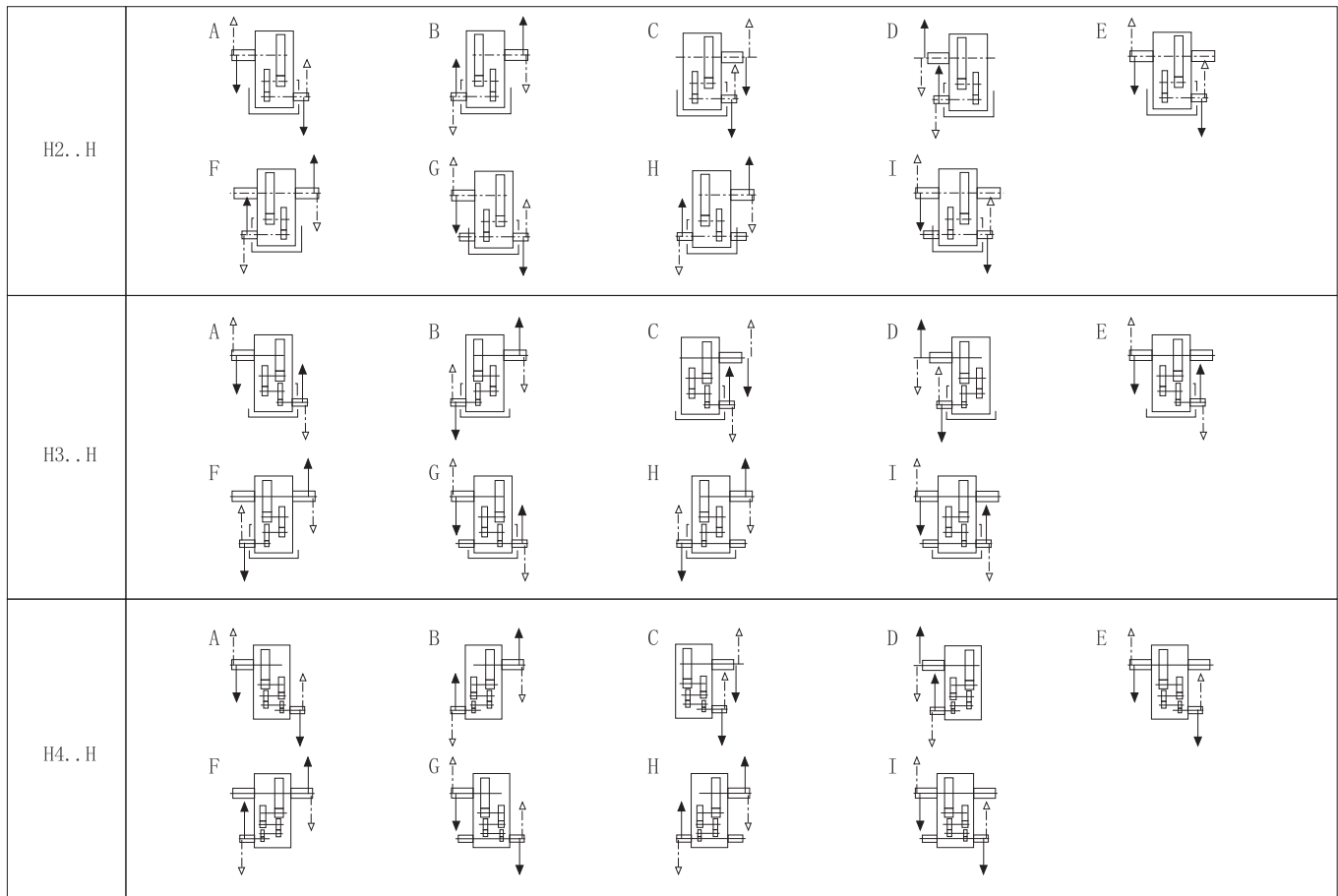

Note: Direction of rotation is reversible

11.2 B series shaft assemblies

11.2.1 Shaft assemblies

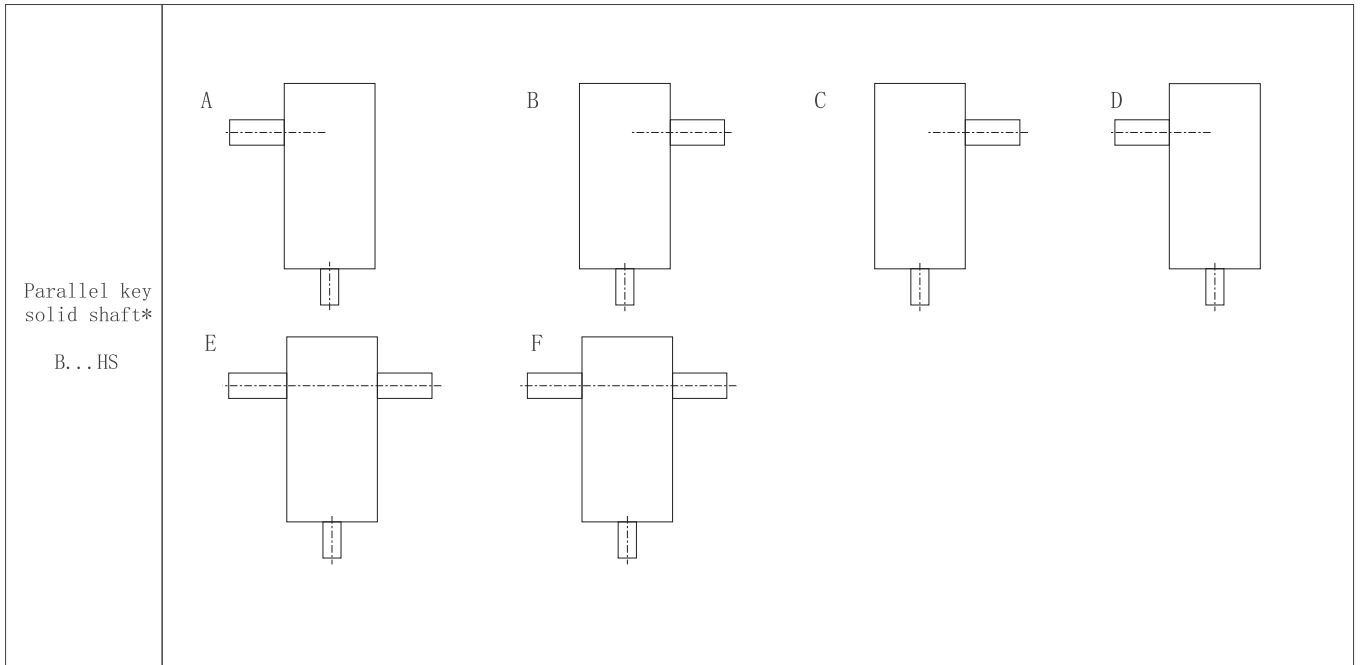

11.2.2 Direction of rotation

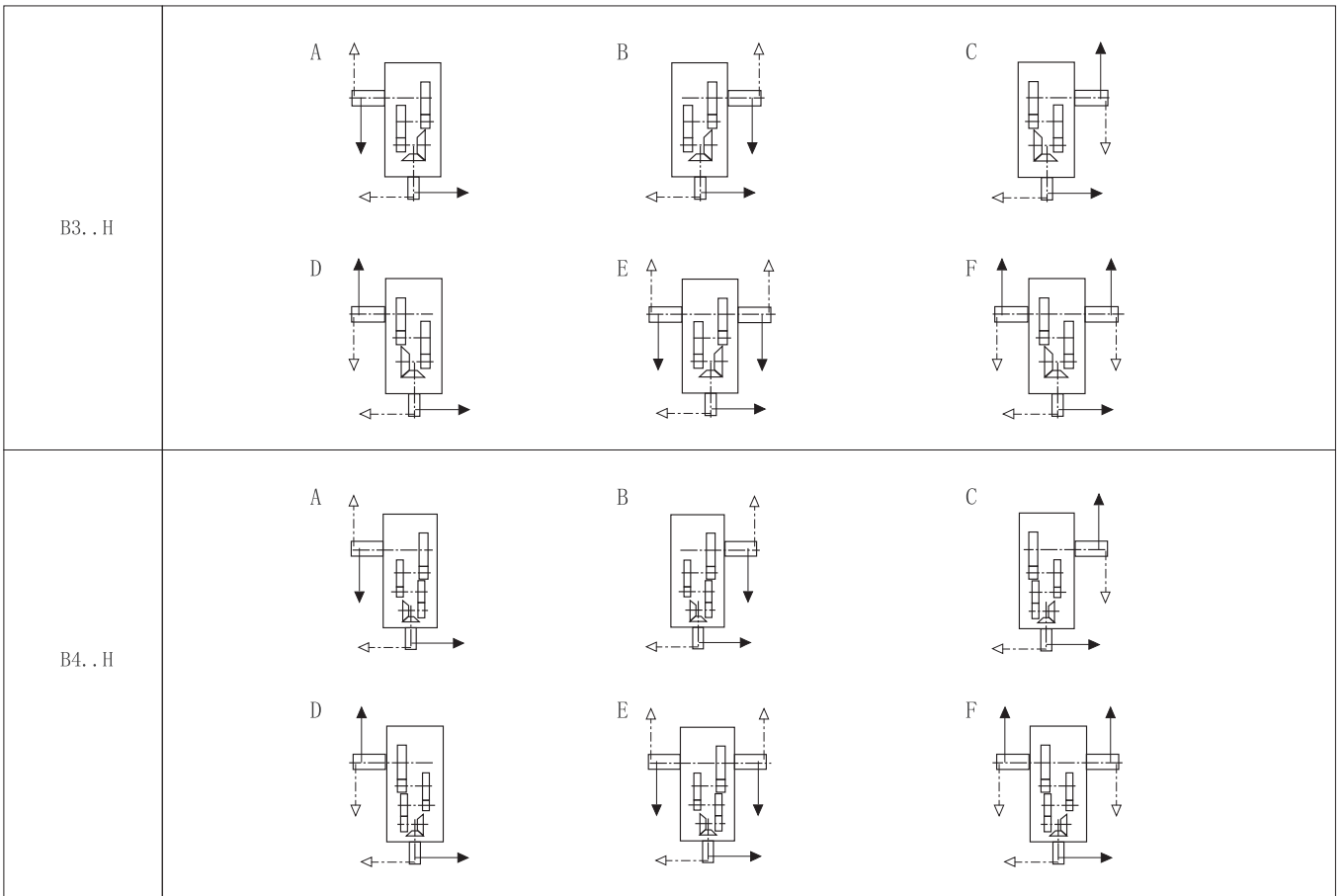

Note: Direction of rotation is reversible

12 Outline dimension

H219H~H226H

H2

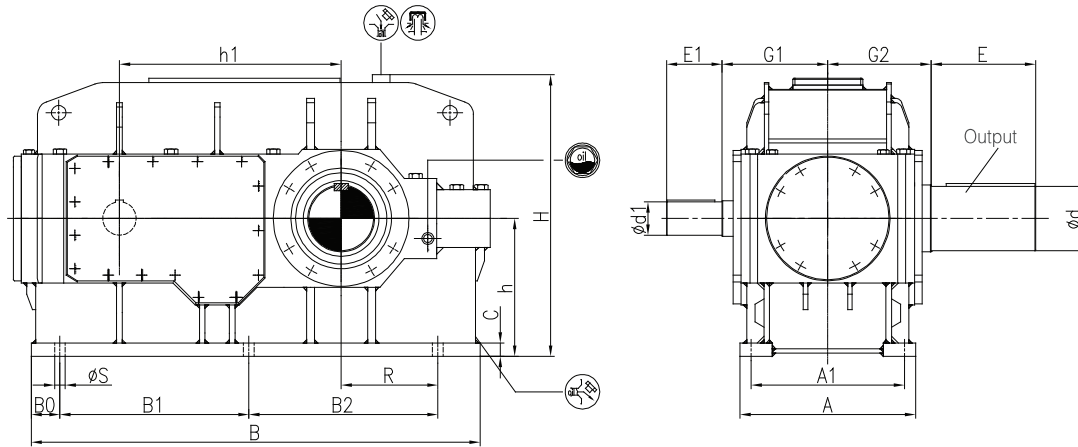

Size	iN=8~10		iN=9~11.2		iN=10		iN=11.2~18		iN=12.5~20		A	A1	B
	d1	E1	d1	E1	d1	E1	d1	E1	d1	E1			
19	150m6	250					120m6	210			790	690	2010
20			150m6	250					120m6	210	790	690	2130
21	170m6	300					140m6	250			830	720	2150
22			170m6	300					140m6	250	830	720	2260
23	190m6	350					150m6	250			930	810	2400
24			190m6	350					150m6	250	930	810	2540
25					200m6	350	170m6	300			1050	910	2695
26					200m6	350	170m6	300			1050	910	2855

Size	B0	B1	B2	C	d	E	G1	G2	H	h	h1	R	S	Weight (kg)
19	120	850	850	60	290n6	470	475	465	1270	620	997	435	48	6600
20	120	850	970	60	310n6	470	475	465	1270	620	1057	495	48	7600
21	155	900	900	70	330n6	550	495	490	1425	700	1067	485	56	9000
22	155	900	1010	70	350n6	550	495	490	1425	700	1122	540	56	9800
23	155	1010	1010	80	370n6	550	560	540	1565	780	1185	550	56	12500
24	155	1010	1140	80	390n6	650	560	540	1565	780	1250	615	56	14000
25	230	1090	1090	90	410n6	650	600	605	1785	860	1325	590	66	16800
26	230	1090	1270	90	430n6	650	600	605	1785	860	1415	680	66	18600

H319H~H326H

H3

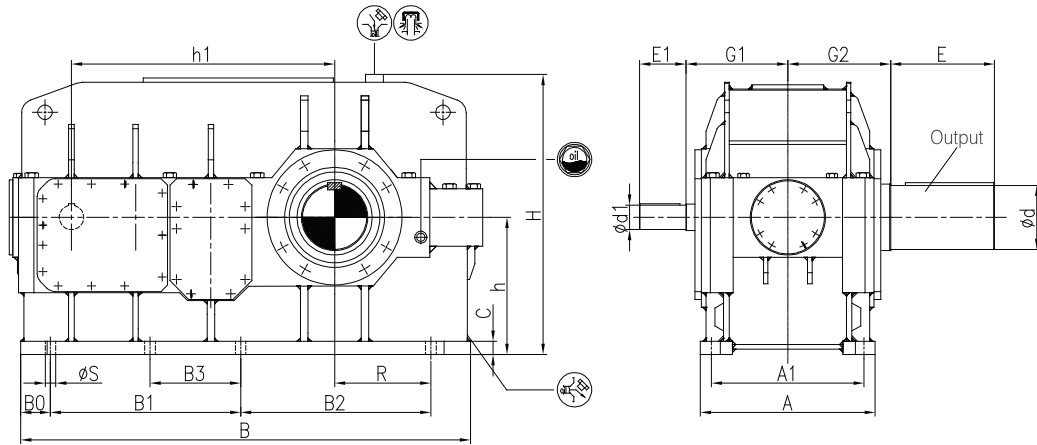

Size	iN=16~45		iN=16~50		iN=18~45		iN=20~50		iN=50~71		iN=50~80		iN=56~80		iN=56~90	
	d1	E1	d1	E1	d1	E1	d1	E1	d1	E1	d1	E1	d1	E1	d1	E1
19	110m6	210									90m6	170				
20			110m6	210											90m6	170
21					130m6	250			110m6	210						
22							130m6	250					110m6	210		
23					130m6	250			110m6	210						
24							130m6	250					110m6	210		
25						150m6	250					130m6	250			
26						150m6	250					130m6	250			

Size	A	A1	B	B0	B1	B2	B3	C	d	E	G1	G2	H	h	h1	R	S	Weight (kg)
19	790	690	2035	135	860	860	/	60	290n6	470	440	465	1270	620	1190	435	48	6700
20	790	690	2165	135	860	980	/	60	310n6	470	440	465	1270	620	1250	495	48	8200
21	830	720	2375	155	1000	1000	/	70	330n6	550	470	490	1425	700	1387	485	56	9200
22	830	720	2465	155	1000	1110	/	70	350n6	550	470	490	1425	700	1442	540	56	10000
23	930	810	2560	180	1185	985	545	80	370n6	550	515	540	1565	780	1505	550	56	12400
24	930	810	2715	180	1185	1115	545	80	390n6	650	515	540	1565	780	1570	615	56	14500
25	1050	910	2890	175	1350	1080	640	90	410n6	650	580	605	1785	860	1695	590	66	17400
26	1050	910	3050	175	1350	1260	565	90	430n6	650	580	605	1785	860	1785	680	66	19000

H419H~H426H

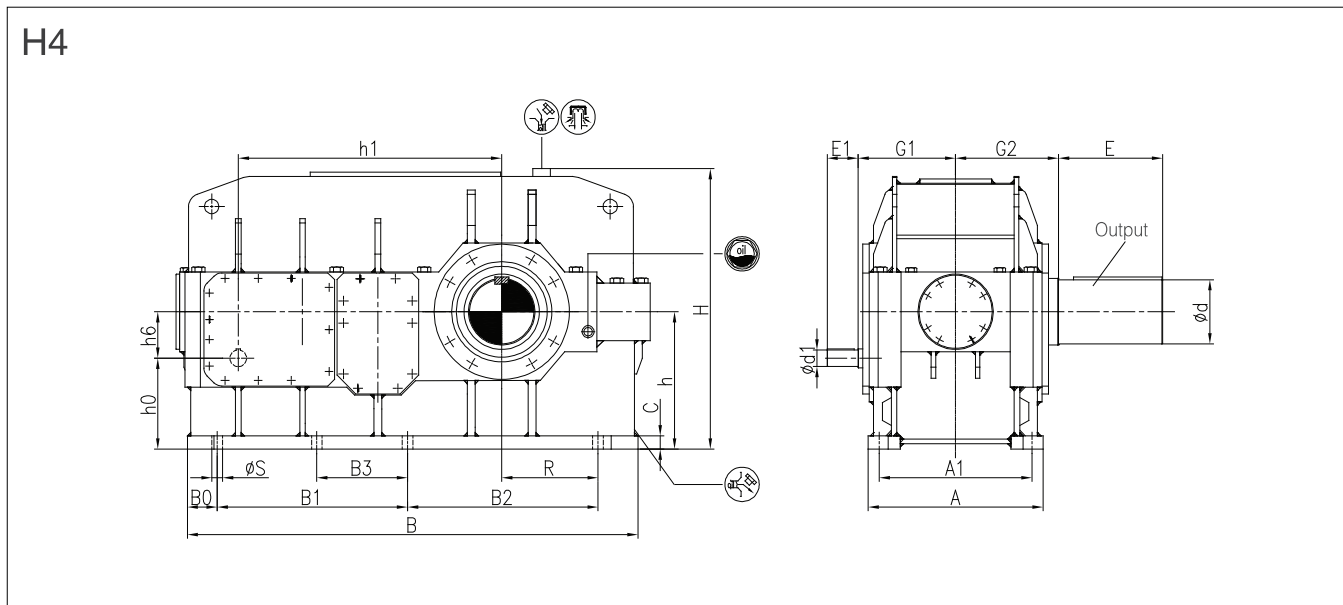

Size	iN=63~200		iN=71~200		iN=71~224		iN=224~355		iN=224~400		iN=250~450		A	A1	B	B0
	d1	E1	d1	E1	d1	E1	d1	E1	d1	E1	d1	E1				
19			75m6	140					60m6	140			790	690	2035	135
20					75m6	140					60m6	140	790	690	2165	135
21			90m6	170					70m6	140			830	720	2375	155
22					90m6	170					70m6	140	830	720	2465	155
23	90m6	170							70m6	140			930	810	2560	180
24					90m6	170					70m6	140	930	810	2715	180
25	100m6	210					85m6	170					1050	910	2890	175
26	100m6	210					85m6	170					1050	910	3050	175

Size	B1	B2	B3	C	d	E	G1	G2	H	h	h0	h1	h6	R	S	Weight (kg)
19	860	860	/	60	290n6	470	440	465	1270	620	410	1190	210	435	48	6800
20	860	980	/	60	310n6	470	440	465	1270	620	410	1250	210	495	48	8300
21	1000	1000	/	70	330n6	550	460	490	1425	700	444	1387	256	485	56	9300
22	1000	1110	/	70	350n6	550	460	490	1425	700	444	1442	256	540	56	10100
23	1185	985	545	80	370n6	550	505	540	1565	780	524	1505	256	550	56	12600
24	1185	1115	545	80	390n6	650	505	540	1565	780	524	1570	256	615	56	14600
25	1350	1080	640	90	410n6	650	565	605	1785	860	568	1695	292	590	66	17400
26	1350	1260	565	90	430n6	650	565	605	1785	860	568	1785	292	680	66	19000

B319H~B326H

B3

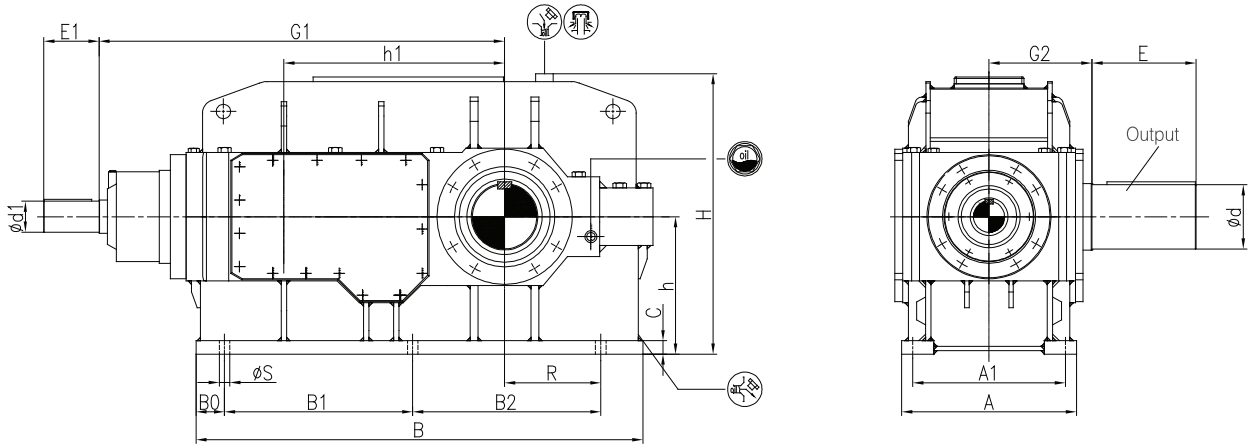

Size	iN=16~56		iN=16~63		iN=18~56		iN=20~56		iN=20~63		iN=22. 4~56		iN=22. 4~63		iN=63~80		iN=63~90		iN=71~90		
	d1	E1	d1	E1	d1	E1	d1	E1	d1	E1	d1	E1	d1	E1	d1	E1	d1	E1	d1	E1	
19	140m6	250														110m6	210				
20			140m6	250															110m6	210	
21					140m6	250										110m6	210				
22									140m6	250									110m6	210	
23							150m6	250							115m6	210					
24												150m6	250						115m6	210	
25											170m6	300			130m6	250					
26											170m6	300			130m6	250					

Size	A	A1	B	B0	B1	B2	C	d	E	G1	G2	H	h	h1	R	S	Weight (kg)
19	790	690	2010	120	850	850	60	290n6	470	1832	465	1270	620	997	435	48	7000
20	790	690	2130	120	850	970	60	310n6	470	1892	465	1270	620	1057	495	48	8300
21	830	720	2150	155	900	900	70	330n6	550	1902	490	1425	700	1067	485	56	9400
22	830	720	2260	155	900	1010	70	350n6	550	1957	490	1425	700	1122	540	56	10000
23	930	810	2400	155	1010	1010	80	370n6	550	2130	540	1565	780	1185	550	56	12500
24	930	810	2540	155	1010	1140	80	390n6	650	2195	540	1565	780	1250	615	56	14500
25	1050	910	2695	230	1090	1090	90	410n6	650	2375	605	1785	860	1325	590	66	17300
26	1050	910	2855	230	1090	1270	90	430n6	650	2465	605	1785	860	1415	680	66	19000

B419H~B26H

B4

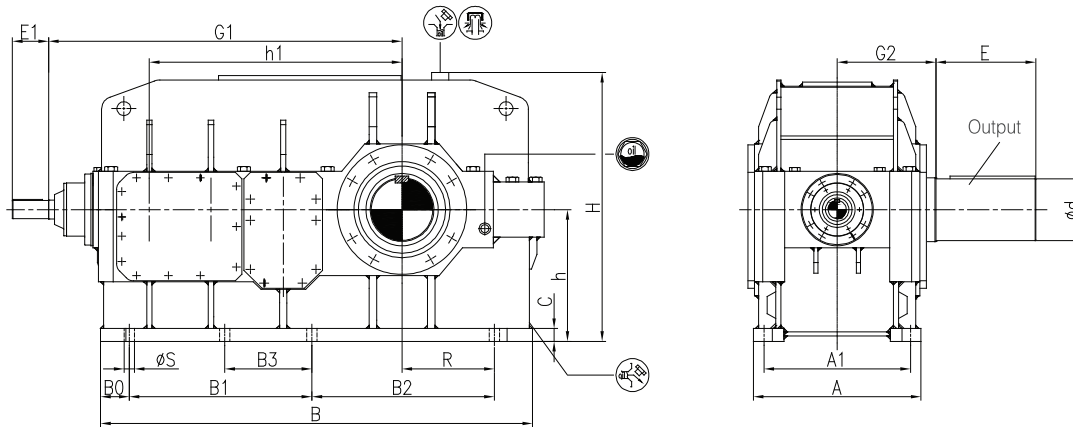

Size	iN=90~250		iN=100~250		iN=100~280		iN=280~355		iN=280~400		iN=315~400		A	A1	B
	d1	E1	d1	E1	d1	E1	d1	E1	d1	E1	d1	E1			
19			85m6	170			70m6	140					790	690	2035
20					85m6	170					70m6	140	790	690	2165
21			95m6	170					75m6	140			830	720	2375
22					95m6	170					75m6	140	830	720	2465
23	95m6	170					75m6	140					930	810	2560
24					95m6	170					75m6	140	930	810	2715
25	115m6	210					90m6	170					1050	910	2890
26	115m6	210					90m6	170					1050	910	3050

Size	B0	B1	B2	B3	C	d	E	G1	G2	H	h	h1	R	S	Weight (kg)
19	135	860	860	/	60	290n6	470	1665	465	1270	620	1190	435	48	6800
20	135	860	980	/	60	310n6	470	1725	465	1270	620	1250	495	48	8300
21	155	1000	1000	/	70	330n6	550	1992	490	1425	700	1387	485	56	9300
22	155	1000	1110	/	70	350n6	550	2047	490	1425	700	1442	540	56	10100
23	180	1185	985	545	80	370n6	550	2110	540	1565	780	1505	550	56	12600
24	180	1185	1115	545	80	390n6	650	2175	540	1565	780	1570	615	56	14600
25	175	1350	1080	640	90	410n6	650	2395	605	1785	860	1695	590	66	17400
26	175	1350	1260	565	90	430n6	650	2485	605	1785	860	1785	680	66	19000

13 Accessories

13.1 Cooling fan (Accessory code UF21)

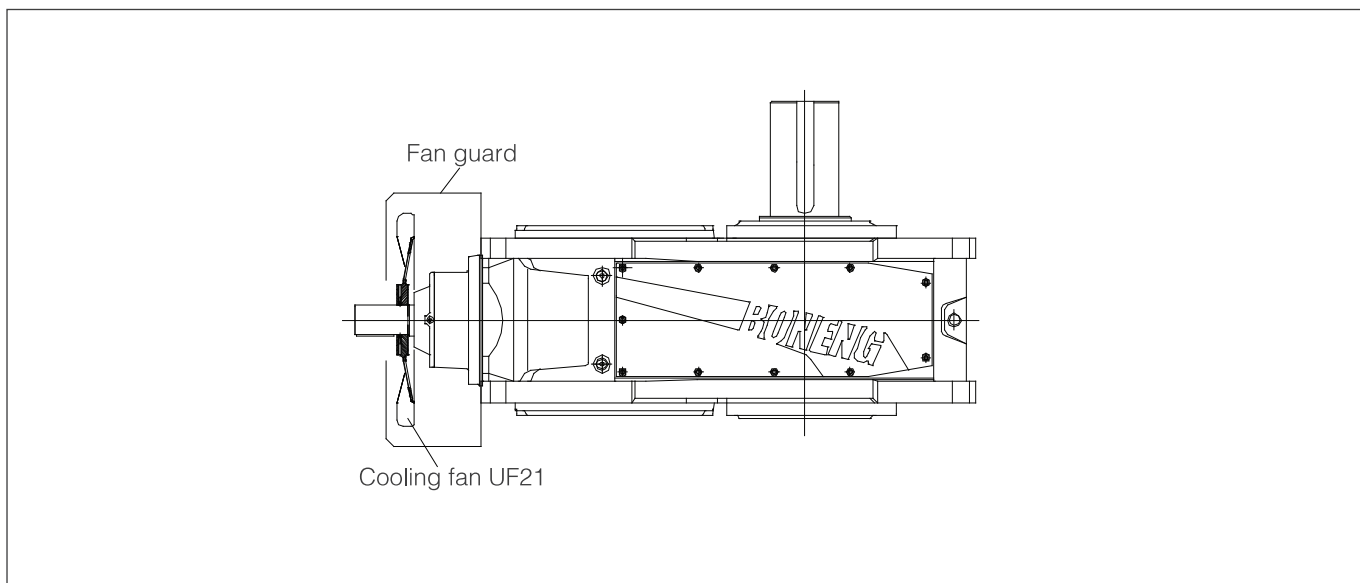

13.2 Water-oil cooler (Accessory code UC22)

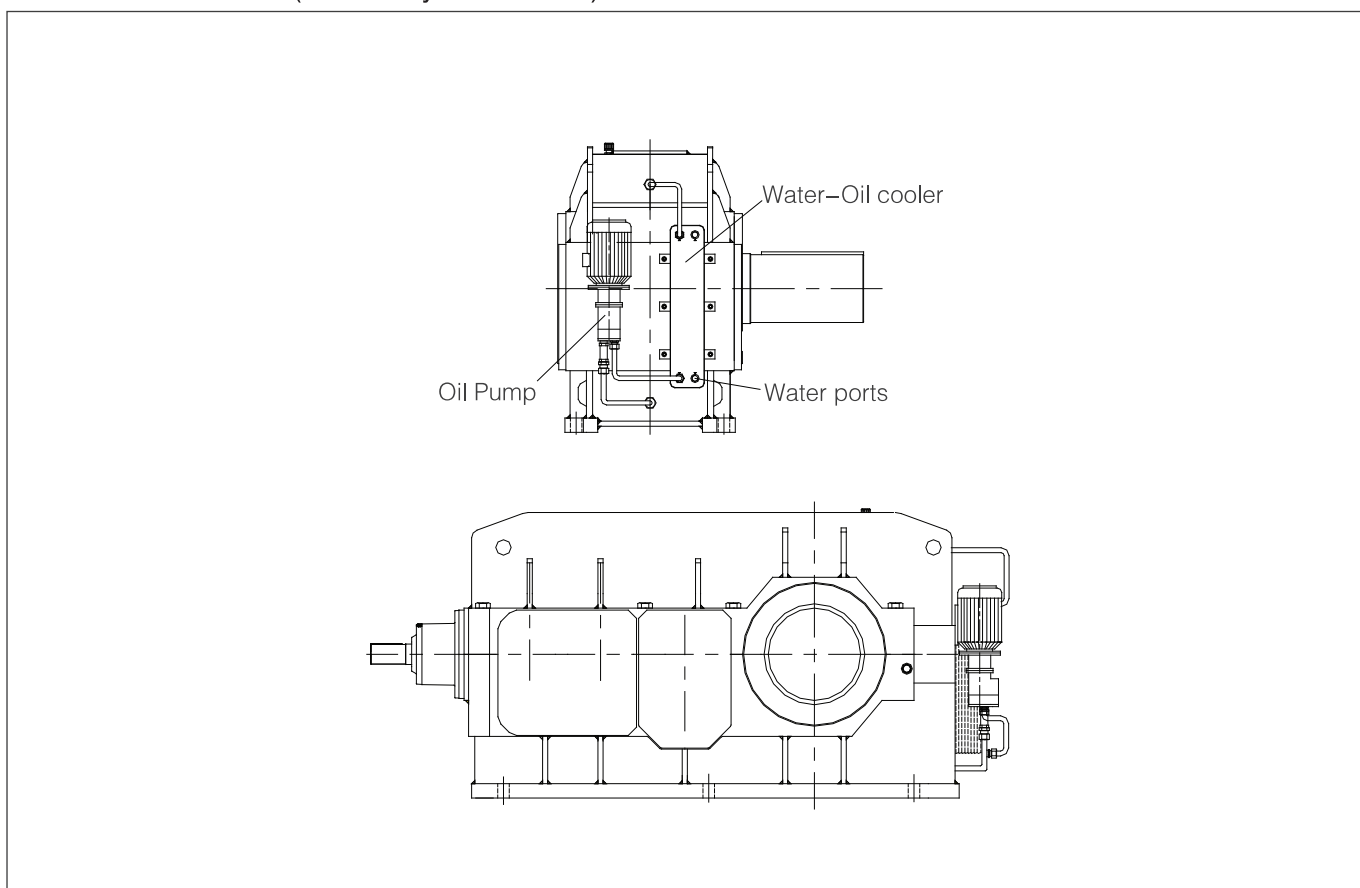

On request.

13.3 Air-oil cooler (Accessory code UC23)

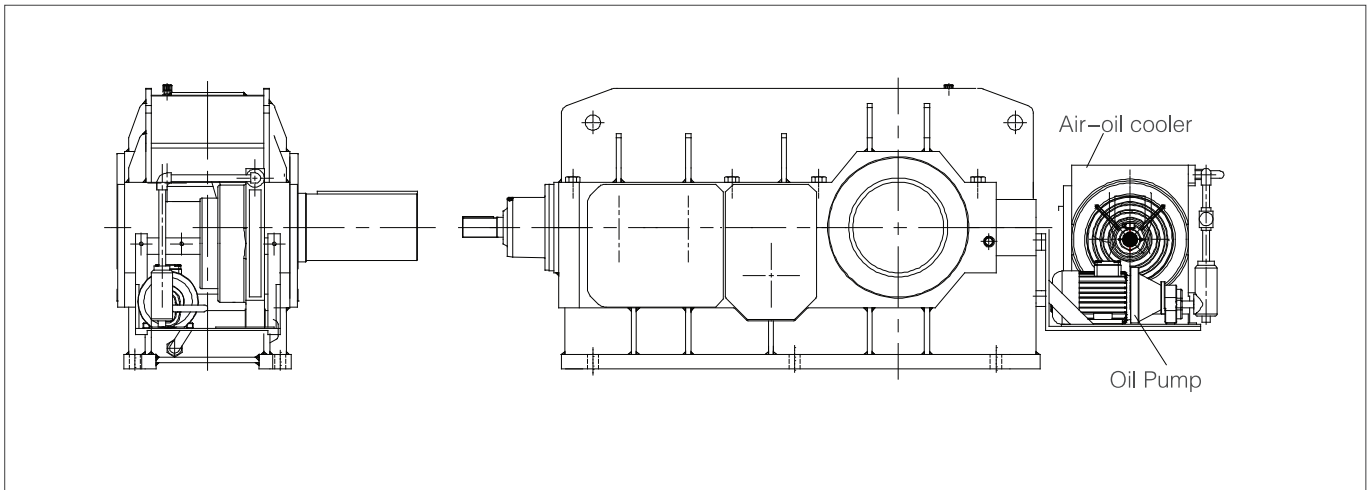

13.4 Backstop (code: UB11)

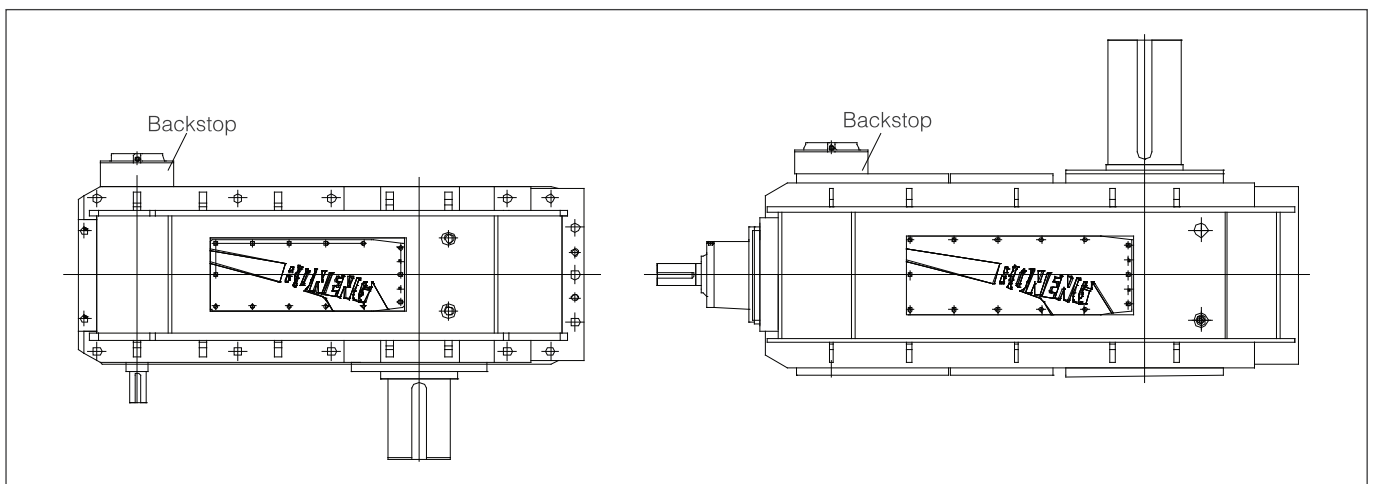

On request.

13.5 Lubrication oil

13.5.1 Oil quantity

Oil Level (L)								
Size	19	20	21	22	23	24	25	26
H2. H	320	340	370	400	430	450	640	680
H3. H	420	450	500	560	620	650	880	935
H4. H	360	380	440	480	520	550	735	780
B3. H	380	440	460	490	530	600	760	880
B4. H	480	550	600	650	710	810	1000	1150



- Note: 1. Oil tank splash lubrication.
2. The above data are average values.

13.5.2 Lubrication oil (heavy-loading industrial gear oil)viscosity number selection [VG320(Accessory code:UV32);VG460(Accessory code:UV46)]

Ambient temperature℃	-20℃~+40℃	+30℃~+50℃
Viscosity number	VG320	VG460

-  Note: 1. Viscosity in the above table is ISO-VG Viscosity under 40 °C
2. When ambient temperature is lower than-10°C,synthetic oil must be used.
3. To ensure product lifespan, we suggest synthetic oil.
4. IF ambient temperature exceeds the above range, please consult.

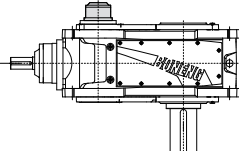
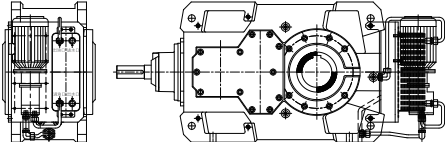
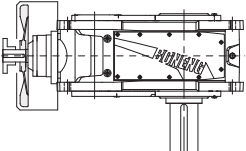
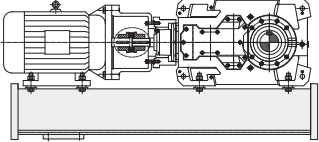
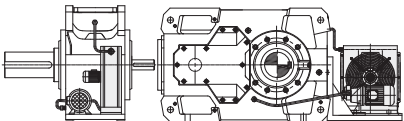
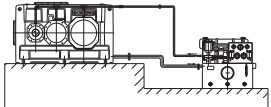
13.6 Accessories code table

Code	Accessories	Example
UB11	Backstop	
UC22	Water-Oil cooler	
UF21	Cooling fan	
UV32	Lubrication oil VG320	
UV46	Lubrication oil VG460	
Please consult	Gear box swing base	
	External wind air-oil cooler UC23	
	Pipeline(Customer build oil station)	
	Electric heater	
	Shaft sealing of other categories	

14 Screw hole in shaft end

14.1 Type C screw central hole in shaft end

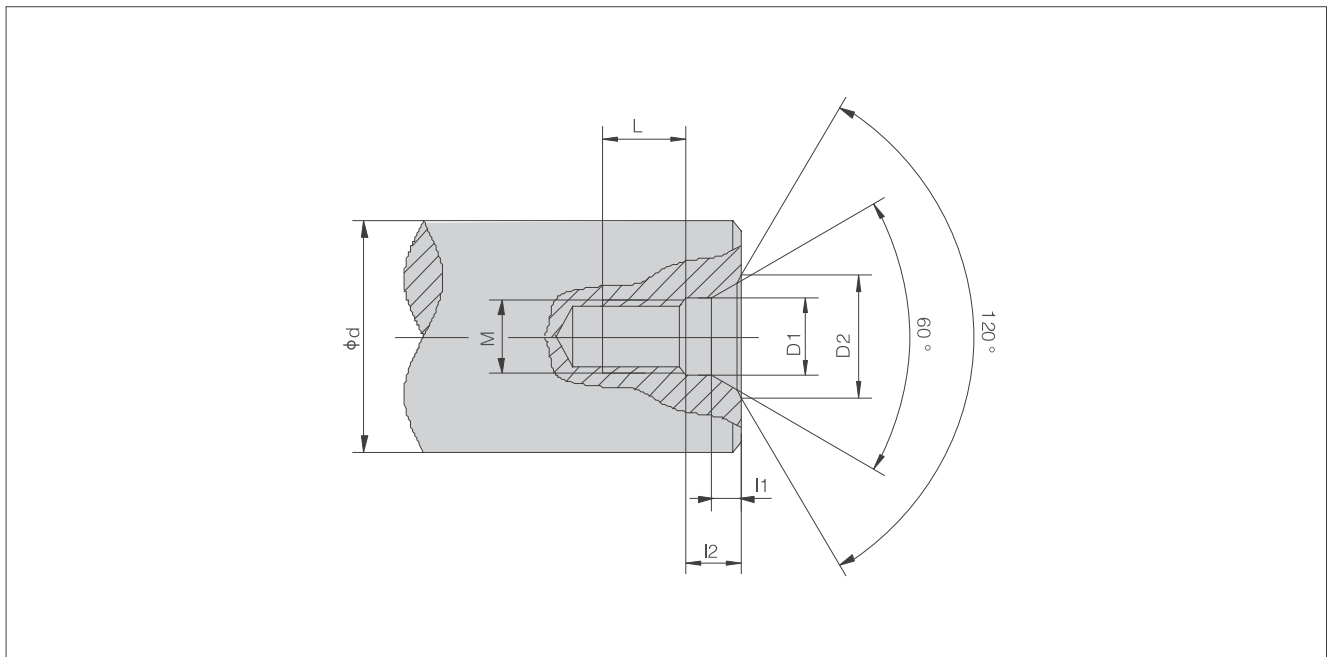

d	M	L	l2	l1	D1	D2
7 < D0 ≤ 10	M3	10	2.6	1.8	3.2	5.8
10 < D0 ≤ 13	M4	10	3.2	2.1	4.3	7.4
13 < D0 ≤ 16	M5	10	4	2.4	5.3	8.8
16 < D0 ≤ 21	M6	12	5	2.8	6.4	10.5
21 < D0 ≤ 24	M8	12	6	3.3	8.4	13.2
24 < D0 ≤ 30	M10	15	7.5	3.8	10.5	16.3
30 < D0 ≤ 38	M12	20	9.5	4.4	13	19.8
38 < D0 ≤ 50	M16	25	12	5.2	17	25.3
50 < D0 ≤ 85	M20	30	15	6.4	21	31.3
85 < D0 ≤ 130	M24	35	18	8	26	38
130 < D0 ≤ 225	M30	45	18	11	31	48
225 < D0 ≤ 320	M36	55	22	15	37	60
320 < D0 ≤ 500	M42	60	26	19	43	71
500 < D0 ≤ 710	M48	65	30	23	49	83

15 Parallel keys and keyway

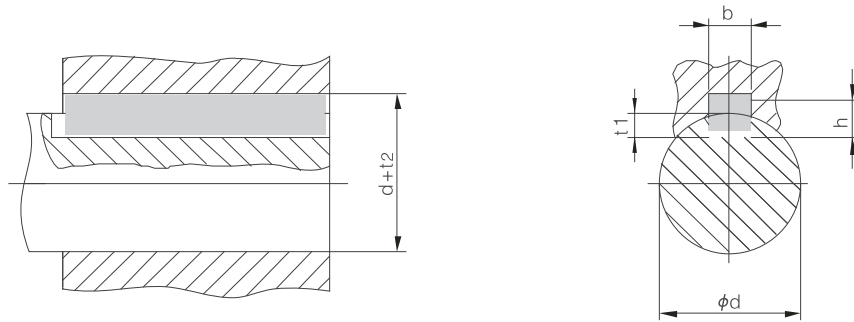

d	b	h	t1	d + t2
8 < d ≤ 10	3	3	1.8	d + 1.4
10 < d ≤ 12	4	4	2.5	d + 1.8
12 < d ≤ 17	5	5	3	d + 2.3
17 < d ≤ 22	6	6	3.5	d + 2.8
22 < d ≤ 30	8	7	4	d + 3.3
30 < d ≤ 38	10	8	5	d + 3.3
38 < d ≤ 44	12	8	5	d + 3.3
44 < d ≤ 50	14	9	5.5	d + 3.8
50 < d ≤ 58	16	10	6	d + 4.3
58 < d ≤ 65	18	11	7	d + 4.4
65 < d ≤ 75	20	12	7.5	d + 4.9
75 < d ≤ 85	22	14	9	d + 5.4
85 < d ≤ 95	25	14	9	d + 5.4
95 < d ≤ 110	28	16	10	d + 6.4
110 < d ≤ 130	32	18	11	d + 7.4
130 < d ≤ 150	36	20	12	d + 8.4
150 < d ≤ 170	40	22	13	d + 9.4
170 < d ≤ 200	45	25	15	d + 10.4
200 < d ≤ 230	50	28	17	d + 11.4
230 < d ≤ 260	56	32	20	d + 12.4
260 < d ≤ 290	63	32	20	d + 12.4
290 < d ≤ 330	70	36	22	d + 14.4
330 < d ≤ 380	80	40	25	d + 15.4
380 < d ≤ 440	90	45	28	d + 17.4
440 < d ≤ 500	100	50	31	d + 19.5
500 < d ≤ 560	110	56	34.3	d + 22.2
560 < d ≤ 640	120	63	39	d + 24.5

Along with the technology advancedet.,the product of the manual of Boneng will be changed,please forgive.

